

Optomechanix

Photonics West 2020 in
San Francisco report

Best Ideas at the Show

New Micromax System

Momories from SPIE

An affordable fluorescence
microscope

Jan-Mar 2020

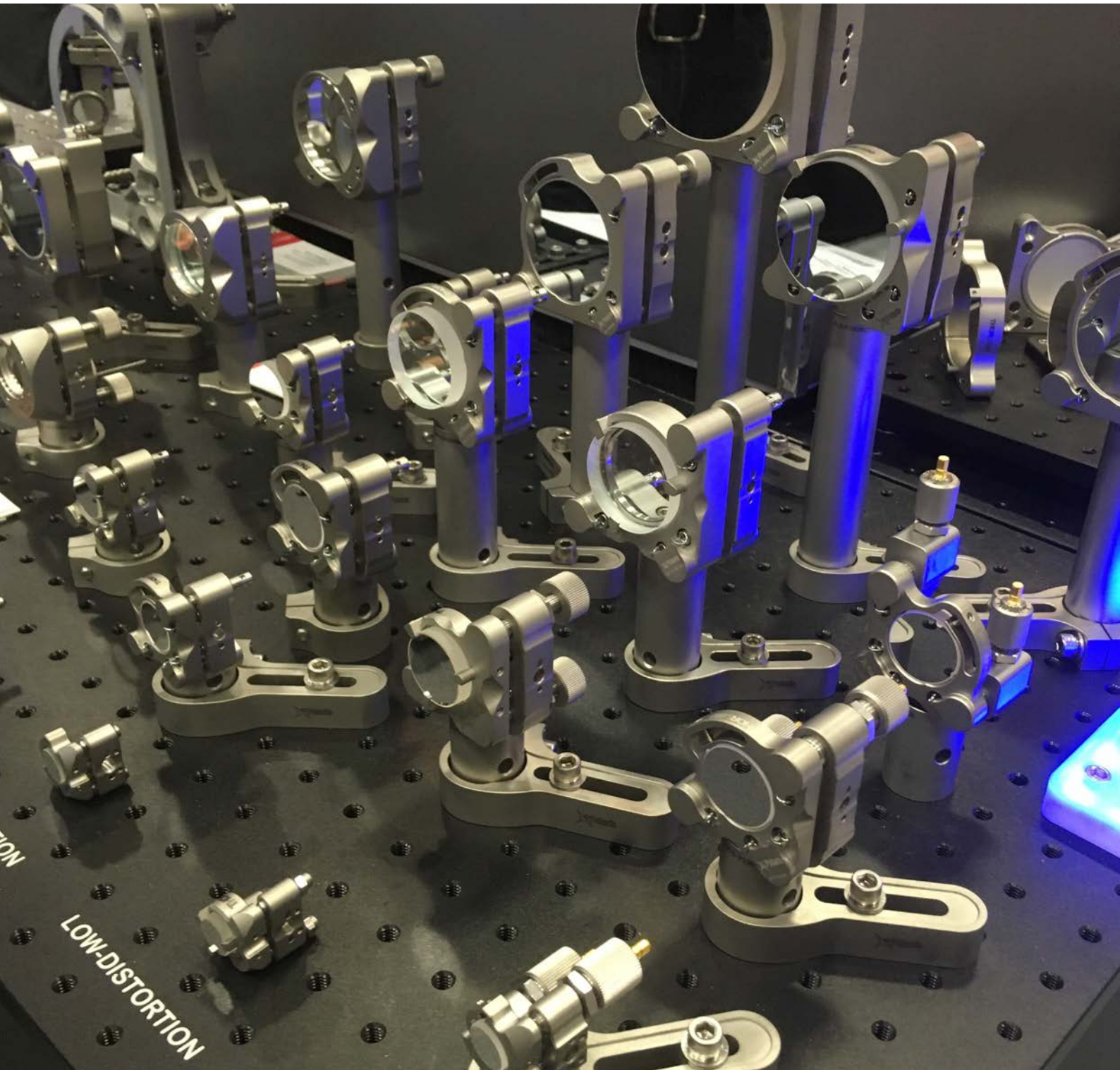

Technical journal of OMID, Opto Mechanical Institute of Design

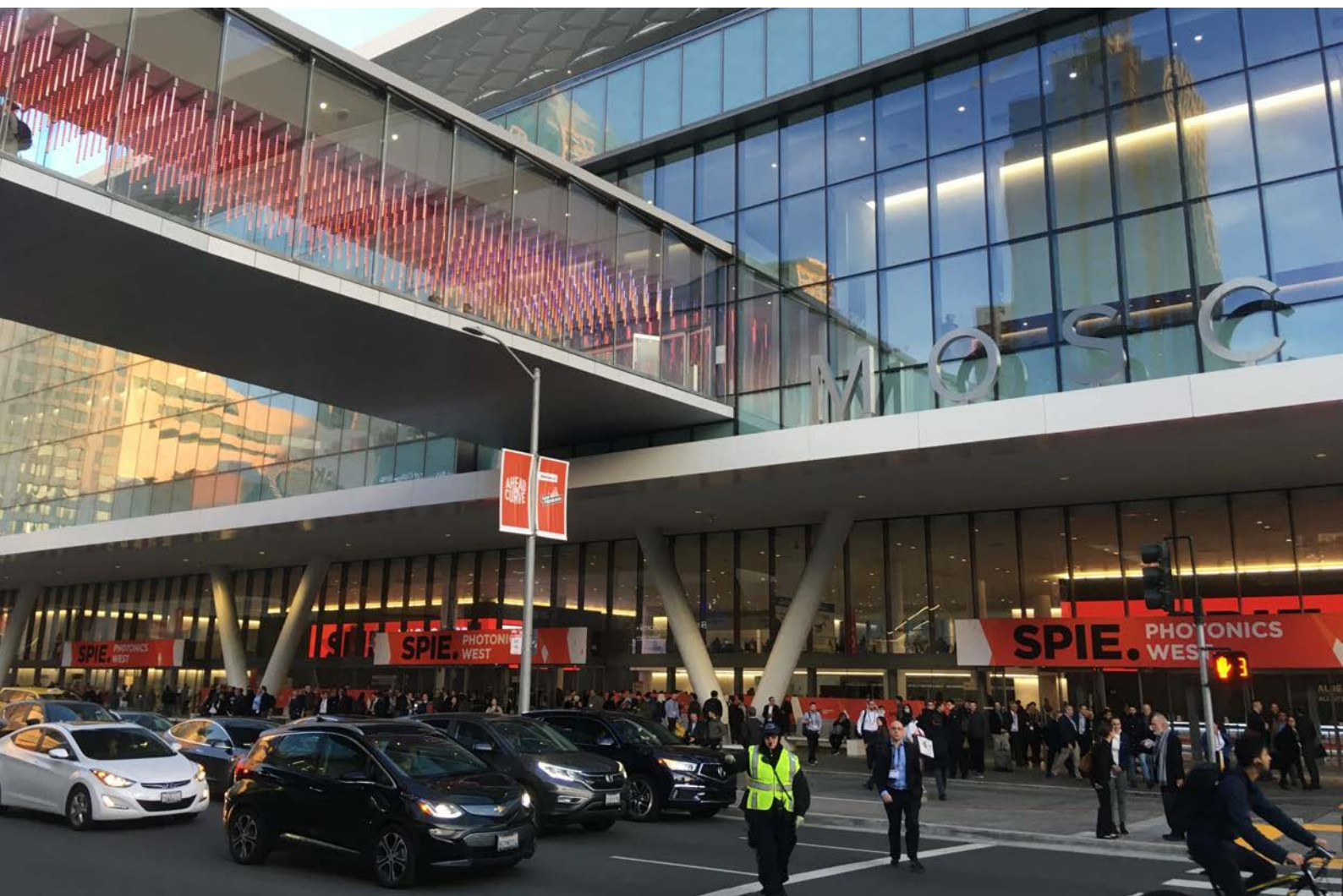

The entry of Moscone trade center in San Francisco at 3rd, and Howard street.

Contents

Page

Attending Photonics West in San Fransisco	3
International Presence	6
The Best New Products at the Show	7
New Micromax System	14
My Reunion with SPIE	18
An affordable Fluorescence Microscope	21

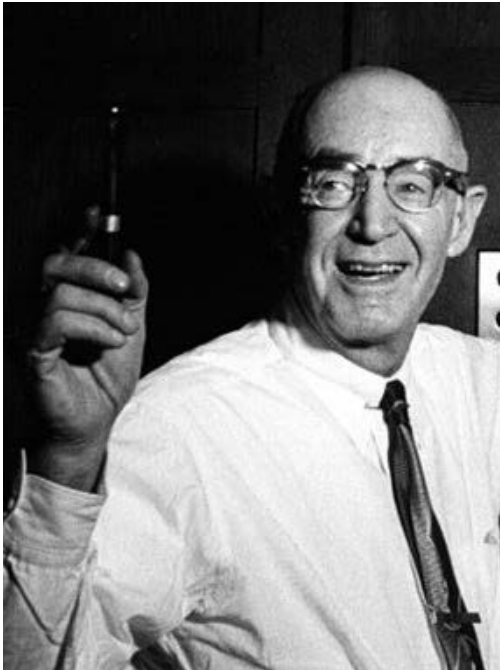

This issue Dedicated to:

Alfred Carlton Gilbert (1884-1962) was the inventor of Erector Set. He was an athlete, a magician, and toy maker, and businessman. He worked as a magician to pay for his education at Yale university and got a degree in sports medicine. As an athlete, he broke several world records. Later in life, he founded the A.C. Gilbert company, and applied for a patent for his Erector Set called: "Mechanics made easy" in 1901.

He was inspired by girders (large construction beams) by Hartford rail road company in New York. In World War I, the Council of National Defense considered a ban on toy production, Gilbert argued successfully against it. The press gave him the nickname "The man who saved Christmas."

By 1935, he had sold more than 30 million of the sets. He also added chemistry sets, microscope and at least one or two optics sets, and other educational toys to his product line, accumulating more than 150 patents during his 50-year career. Frustrated that invention was an important part of American society not taught in schools, in 1941 Gilbert opened the Gilbert Hall of Science in New York City, a science

and technology museum. It served the dual purpose of promoting interest in science and selling Gilbert's products.

Source: Wikipedia.com



The original Erector Set of 1920 had gears, assembly plates with bolt patterns, nuts, and bolts, etc.

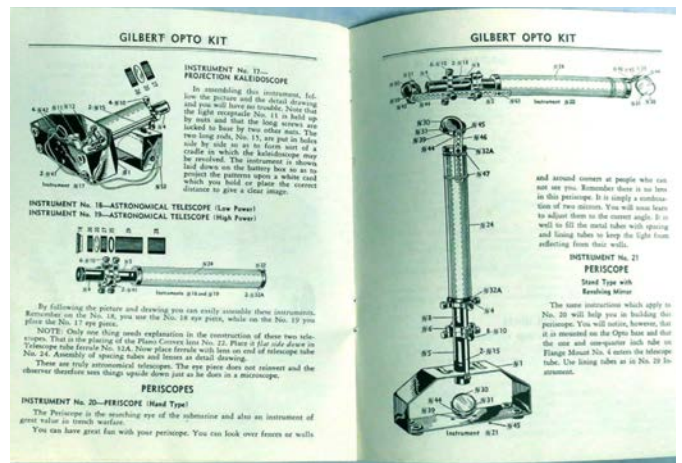

Gilbert's sets such as this Optics kit came with good old instructions manuals that treated children like engineers.

Copyright 2020
 Web: www.optomechanix.org
 For digital subscription or suggestions email us at:
info@optomechanix.com
 Chief Editor: Ali Afshari
 Publicity Coordinator: Smaneh Karimabadi

Optomechanix is a quarterly journal of Opto-Mechanical Institute of Design (OMiD), with technical articles for practical, hands-on audience. This magazine is privately founded, and is free of charge.

Cover page photo: Thorlabs stainless steel low distortion tiltable mirror mounts.
Inside page photo: Entrance to the Moscone center, North, and South halls.

Attending Photonics West Show 2020

I congratulate SPIE for putting this show together, and growing the show to how big it is today: The exhibition floor was fully packed this year with 20,406 registered attendees, and 1,304 exhibiting companies. The Bios Show has expanded to two full days in past few years, and the registered attendees this year reached 7,892 and the number of exhibition companies reached 218. As a city, San Francisco has far more attraction to tourists, but for people who live in the vicinity, it's a city that you'll have a hard time finding parking for your car. Parking fees at the parking garage right next to Moscone center was \$40 a day, and if you had planned attending both the Biomedical show (Sat, and Sun), and Photonics West (Tue, Wed, Thu), parking would have cost you a lot. I managed to park for \$14/day. These parking lots offer early bird rates, so if you parked earlier than 10 am, and left after 3 pm, you got a deal. There were plenty of good restaurants, and coffee shops, and overall, San Francisco would have left you a great memory with its vibrant night life.

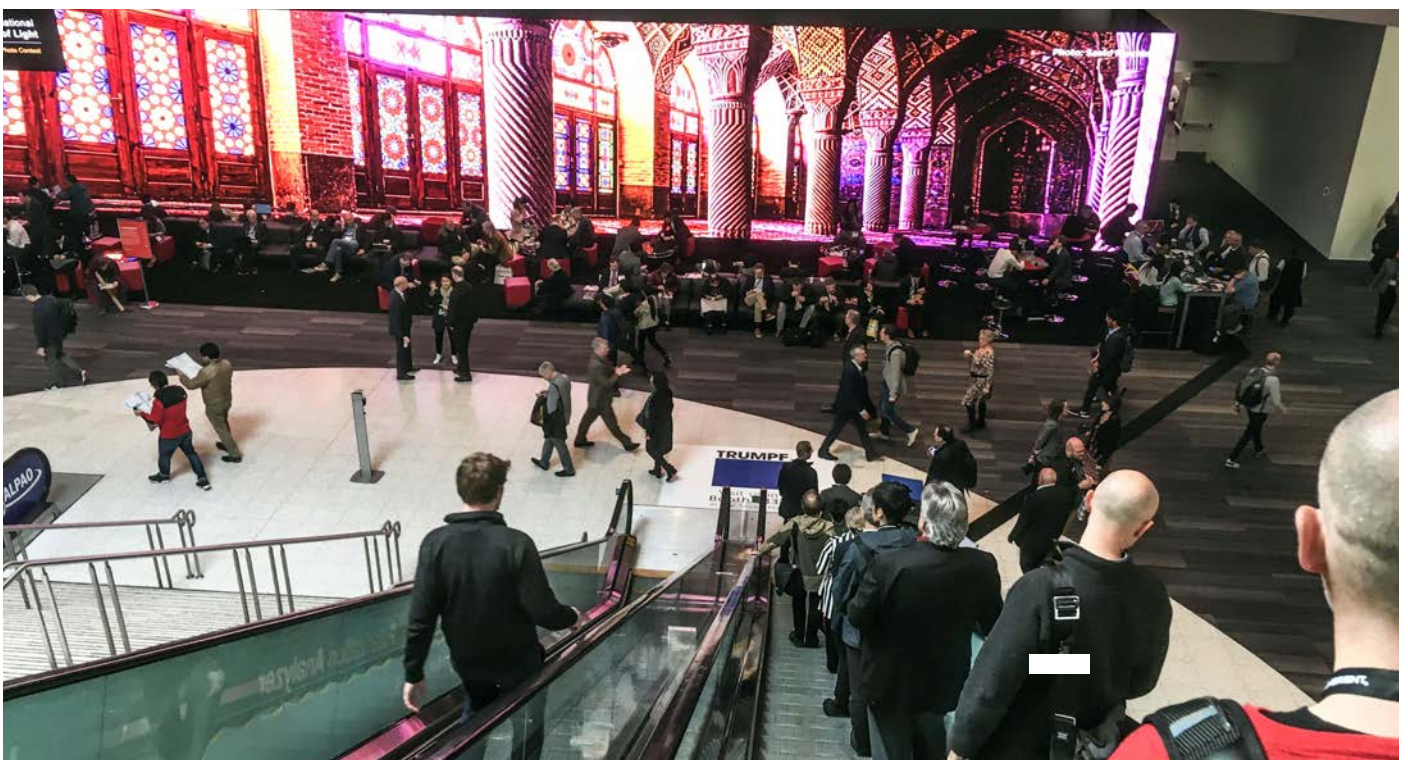
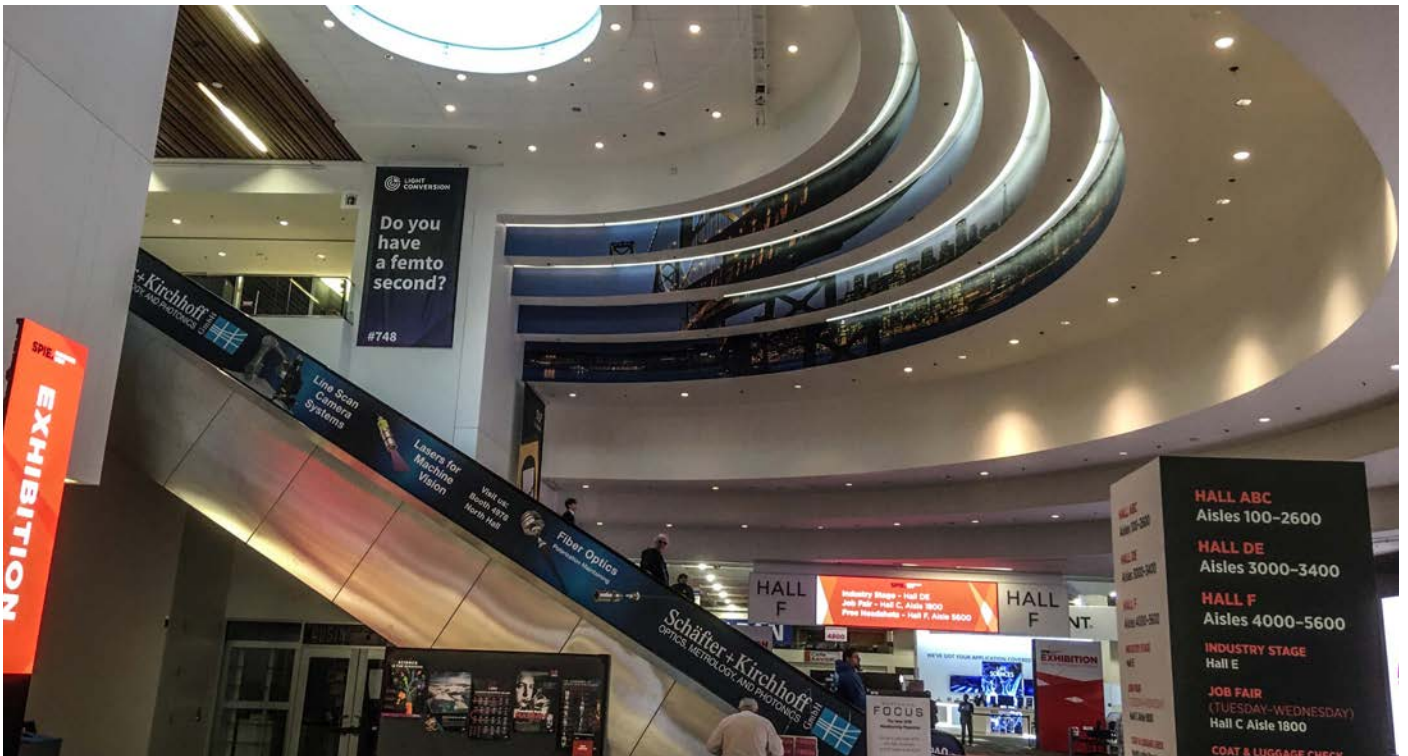

Huge background LED display of SPIE's photo gallery while going down the south hall escalators was spectacular.

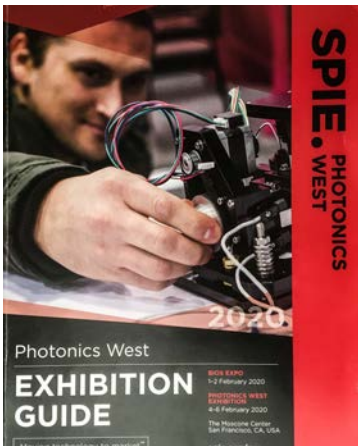

Photonics West offers a complete educational opportunity for the attendees by offering short courses for those who wish to enter a new field. There's a book store that contains many of online books SPIE offers so someone could see the books before purchasing them. There is also an opportunity for authors to speak with SPIE to have their book published, or sell it through SPIE. Every exhibition floor had tutorials for some breakthrough products, and of course, poster shows, and seminars that are held throughout the week. This year there was training courses for start-ups, and two product contests: Start-up Challenge, and the Prism Awards.

I was exhibiting at this show to introduce our new Optoform cage system, and found so few sales people walking around the show as they would in the past, selling ad space for trade magazines. Also on display we had all past issues of Optomechanix magazine, and an actual Hasselblad lunar camera which was covered in past two issues. The visitor guide (above left, center) was well organized with easy to follow layout. You could have downloaded the SPIE app (still on my phone) that helped you find whatever you were looking for on your own phone. I tried to use it to find the Zeiss booth, and it still took me a while. The full color daily newspaper with articles, and events summary (above right) were handed out at the show entrance, and was a pleasant addition to the show experience.

Ali Afshari
OMID

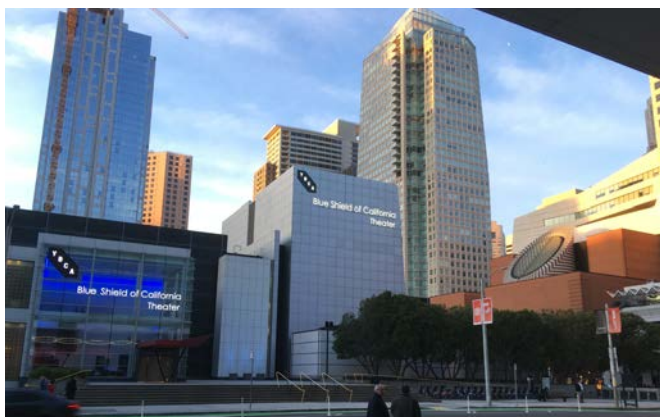

San Francisco view through the registration area



Entry to Mascone center, North hall



Registration, and badge pick up.

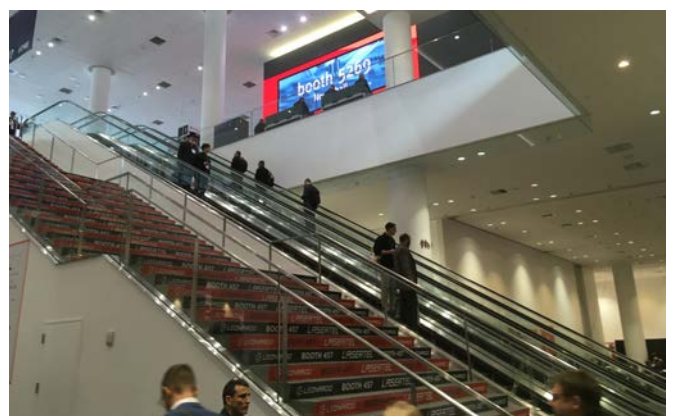

Escalator to the South Hall



Masked attendees were not that uncommon during the show due to the spread of Coronavirus in China.



Coat line, and baggage check hold for overseas travellers. The weather was cold during the one week show.



This eye catching heart sign was a good landmark to enter the Mascone building through its side doors.

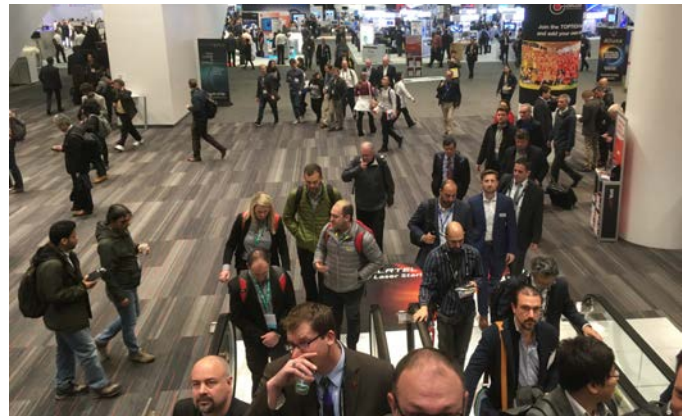

Attendees were happy about the new show logistics that combined North and South halls.



Left, inside the exhibitor's lounge, many meetings were held where exhibitors could invite colleagues to have discussions with WiFi access, and free coffee, and cookies.

SPIE bookshelf has expanded since the past shows (above). Many authors publish papers in much better book format than the dull format you'll find in technical papers.

Above left, many airlines cancelled their flights to, and from China, and I did see a few empty exhibition tables during the show. There were many booths from Asia but most likely many attendees from China couldn't make it to the show.



International Presence



Germany

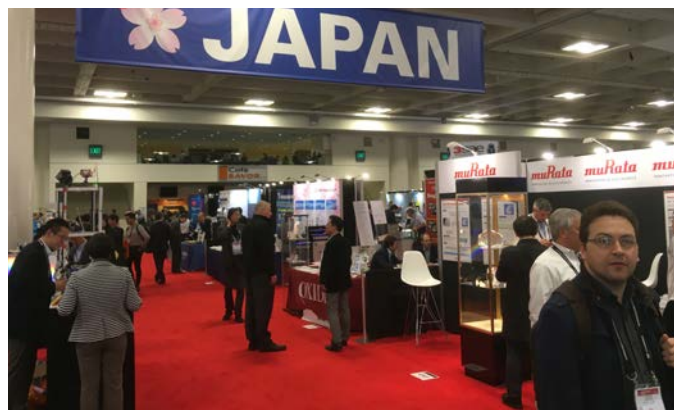

Japan

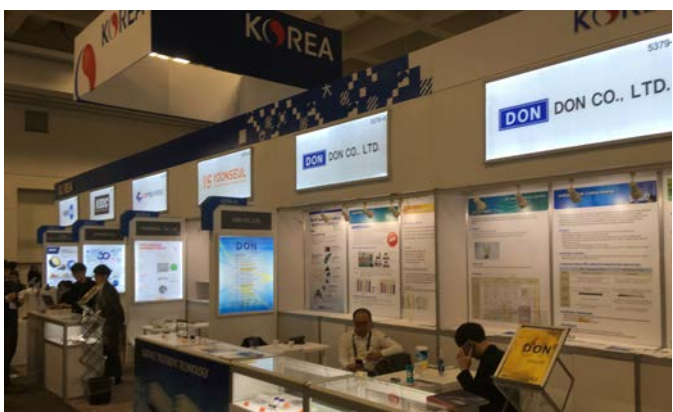

Korea

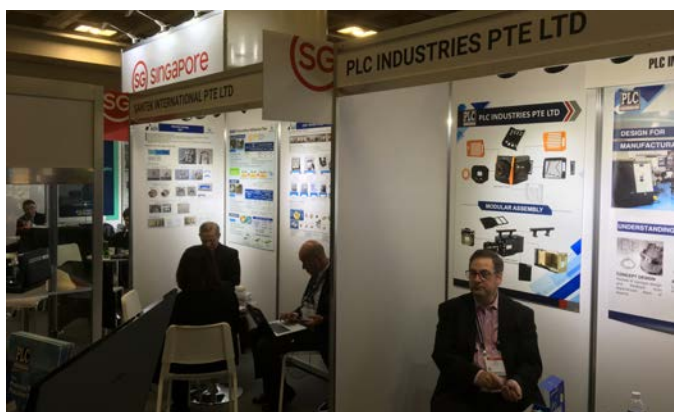

Singapore



Finland



Taiwan



Ireland



Canada

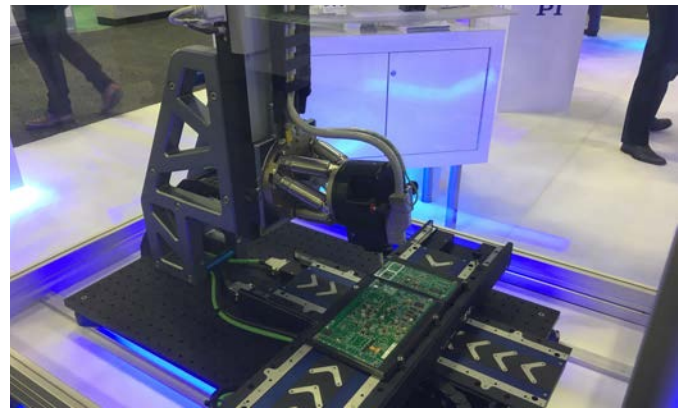

PI Germany had many Hexapod applications that were patiently prepared to increase their visibility among their other products. The setup on the light looks like a rooster head, but it is actually an electronics parts placement machine.

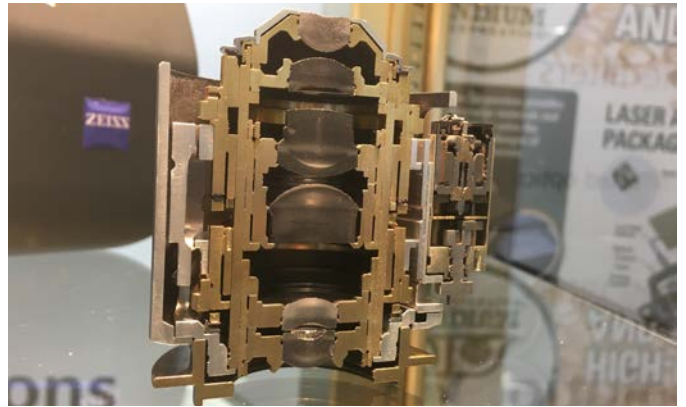

Zeiss Germany: Cross section of motorized microscope objective (right) has automatic correction for aberrations. Zeiss used internal lens shift in cinema optics to correct for focus breathing, and now uses it to correct microscope optics.



Precision telecentric lenses for 6.6 x 8.8 mm format by Zeiss (above), and Monolithic Miniature Spectrometer for OEM, and compact grating spectrometer (right).



Spectral scan cameras (right), Specim has introduced a new airborne unit in addition to their previously announced handheld device. There is a scanning device inside that records multiplicity of images in the visible and IR range in 1 Sec.



Piezosystems Jana, High precision, high load piezo actuator can micro-position up to 30 pounds in 100 micron range at high speed. One obvious application would be shock and vibration testing of opto-mechanical/electronics assemblies.



Compact scanning Inverted microscope by **Jenoptik**. The wireless controlled microscope (right), has detachable module mounts on a 25x25 mm scanning stage on the base, and the sample is held on removable (black) sample holder on top.

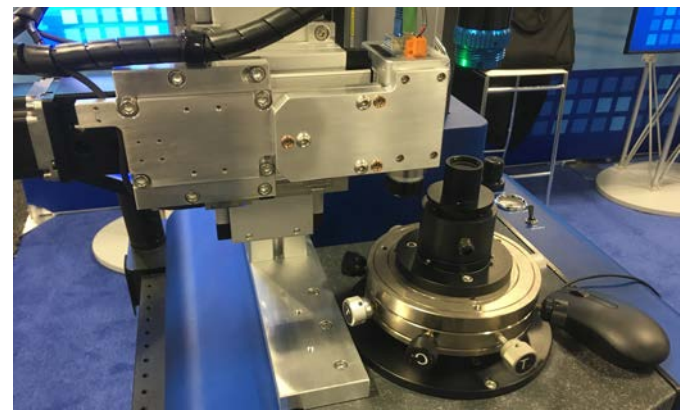
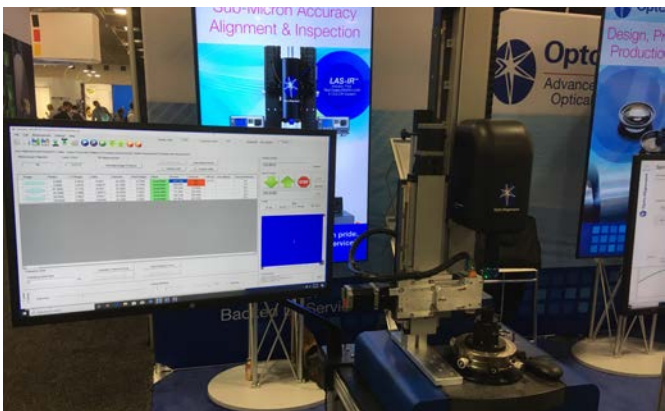

Bench top **Opto Alignment** checks the mechanical centration of optical elements within a lens by rotating it, and displaying the results in a computer screen. One application would be manufacturing high performance microscope objectives.



DiCon offers LED based fiber optics UV lamp illumination. Its wavelength adjuster is not a rotating filter wheel, but an electronic adjustment knob to adjust the LED output wavelength. The light guide is liquid filled.



Nikon microcopy group offers wide range of microscope objectives, illumination heads, observation heads, lens turrets, and manual focusing columns for OEM market.

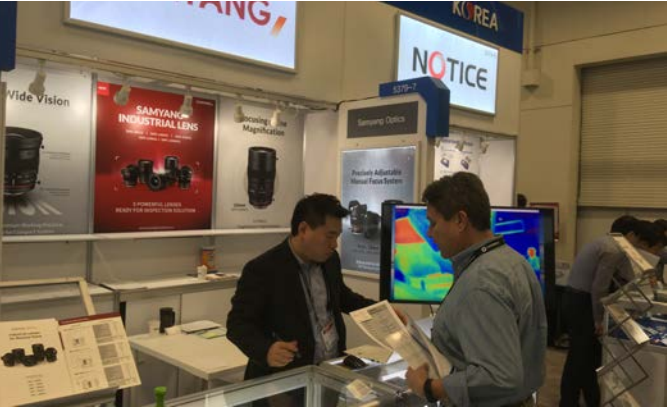

In the photographic market, **Samyang** has been marketing their full frame camera lenses through B&H photo, and other camera outlets. The barrel finish, and control rings are nicely done. Samyang also produces lenses for industrial use.



Heidenhain linear scales and probes (right) offer closed loop as low as 0.1 micrometer resolution. Right, a close-up view of the probe is shown with interpolation of fine lines on the linear scale (below, left).



Above, a close up of the scale. Right, various linear, and rotary scales are shown. Note the curved probe for rotary scale.

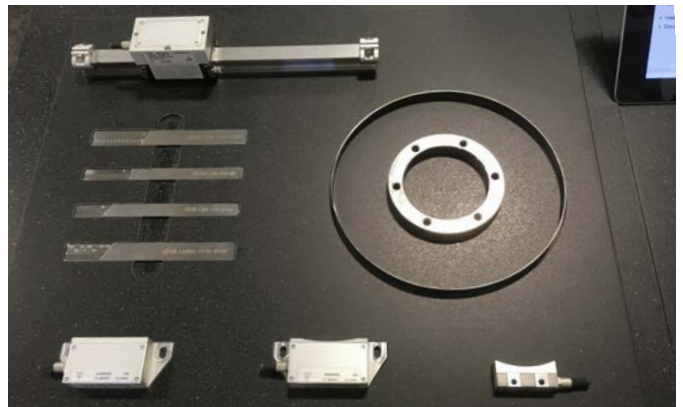



Toplica displayed 589 nm laser mounted on a telescope model that produces artificial star for deformable optics. Deformable optics is essential for telescopes above 25 cm in diameter to cancel out atmospheric turbulations.

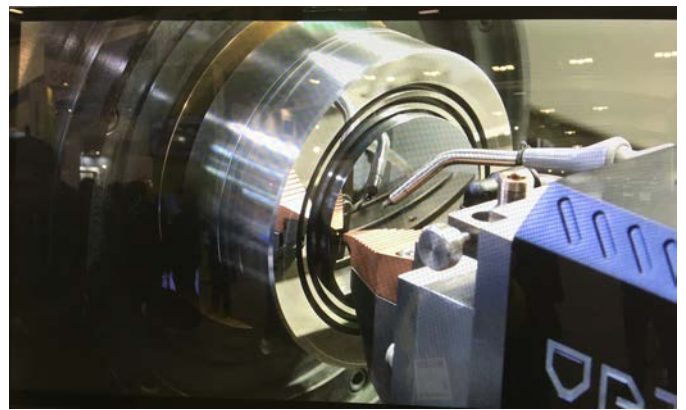

Nanoform makes CNC machinery for diamond turning Aluminium mirrors. There's still a similar product named Optoform, and they were trying to convince me to change my product name! What they didn't think of was it could be Nanoform!

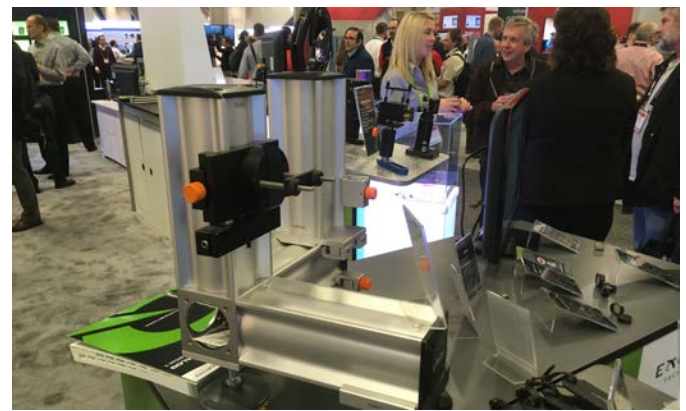

Excelitas owns the Microbench, and X-95 system (right), a German made opto-mechanical line with accessories that Thorlabs made so popular in past two decades. This line was originally sold through Spindler & Hoyer GmbH.

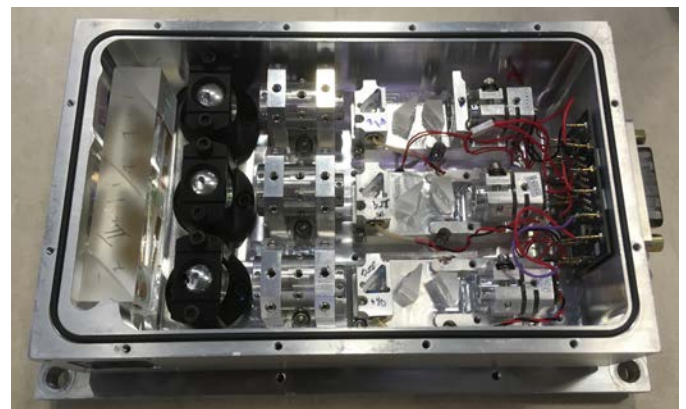

A very interesting prism work (right) on display at **IDEX** booth in a sealed package. The beam from three diode lasers is combined in this multi wavelength source unit for scanning fluorescence microscopy.



MKS booth (what used to be Newport, Ophir, and Spectra Physics) displayed various IR lens assembly, and camera heads (right). This 250 mm diameter lens assembly is an IR lens with 27X zoom range, 50 ~ 1,350 mm at a fast f/5.5

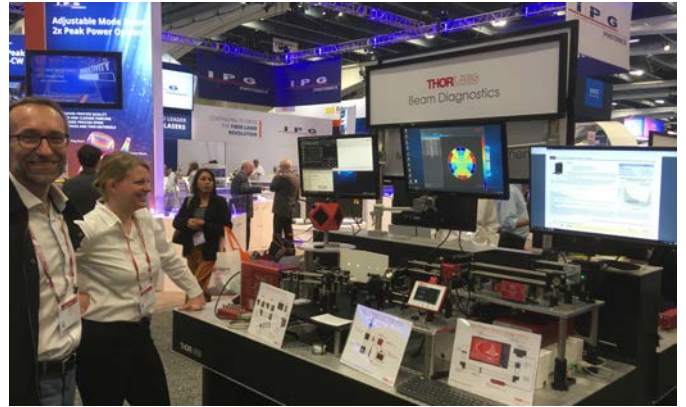
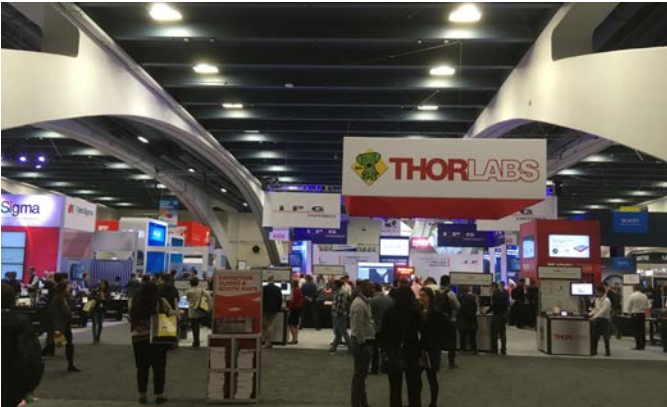

Thorlabs high power beam diagnostics software, and deformable mirror setup (left). Cover page: Stainless steel low distortion tiltable mirror mounts.

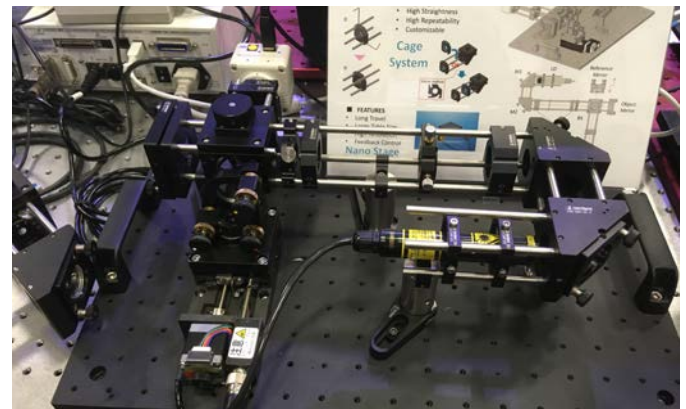

OptoSigma is adding more accessories to their 3-rod cage system (right). They now offer 60 mm cage plates in addition to their 40, and 30 mm mounts. Shown is a michaelson interferometer with a motorized delay line.



Microscope objectives by Shanghai Optics tells the contracts they have been receiving from microscope manufacturers which has improved the quality of their optics. Some of the objectives on display look like Zeiss, Olympus, and Mitutoyo.

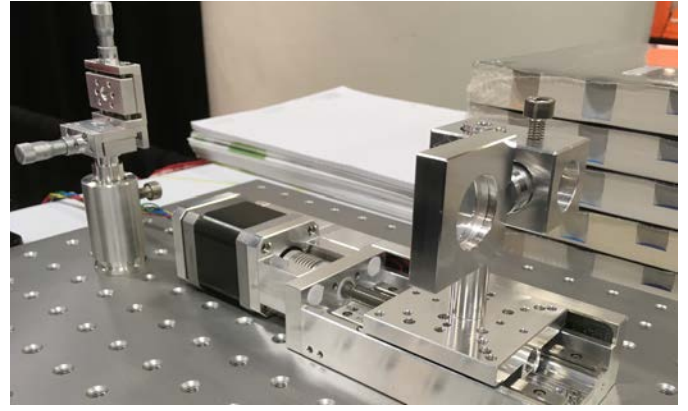
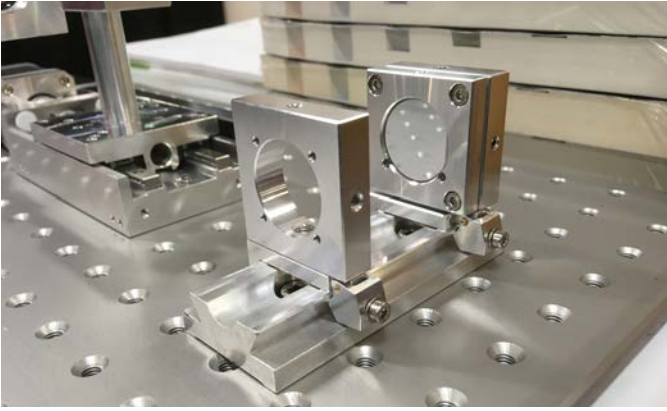

OWIS Ultra High Vacuum $1E(-9)$ mbar components (UHV), and eXtreme Ultra High Vacuum $1E(-11)$ mbar components (XUHV) includes motorized stages, and manual stages. The stages are rigorously cleaned, and use special grease.

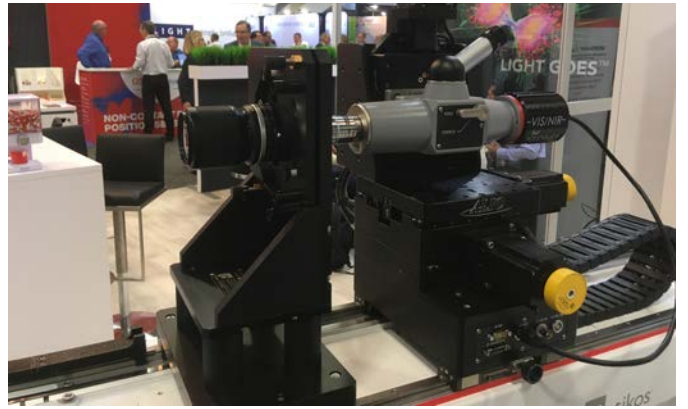

Trioptics automatic image analysis hardware/software focuses on the focal plane image of a test lens (above) via a microscope objective. The image can be focused through an eyepiece or a detector.

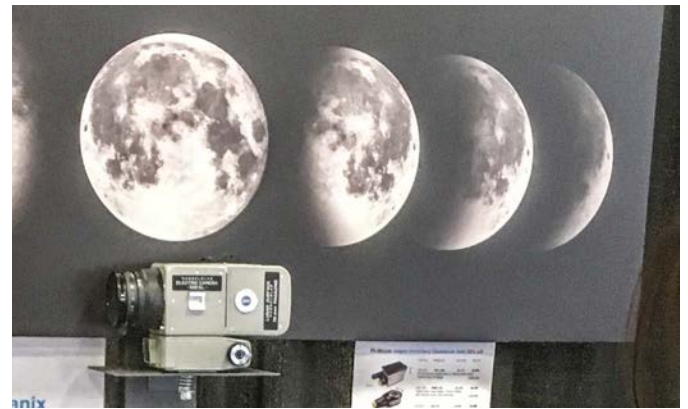
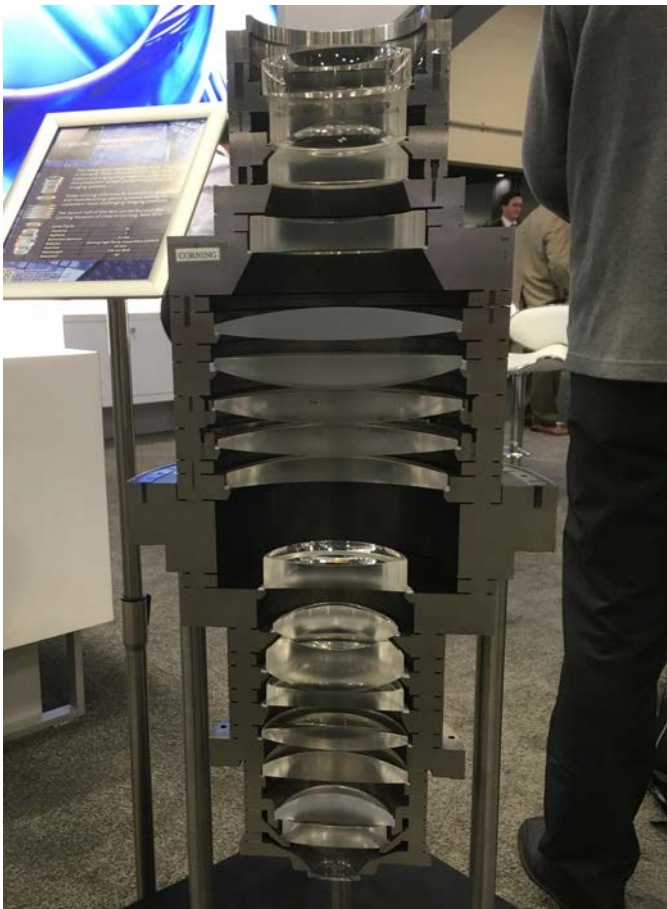

Hasselblad moon camera at **Optomechanix's** stand, also displaying the new Optoform Cage system, and Micromax.



Lithographic lens on display at **Corning Glass** booth.



Touchless Automation has invented a machine that could lift and transport miniature components without touching them. This technology has active control of airflow to lift small parts, with sucking force dependent on weight, and size.



Finland based **Sekonix** rear projection screen produces bright displays in bright daylight.



Canon's galvo division has been marketing their galvo modules, and control units to the optics industry.

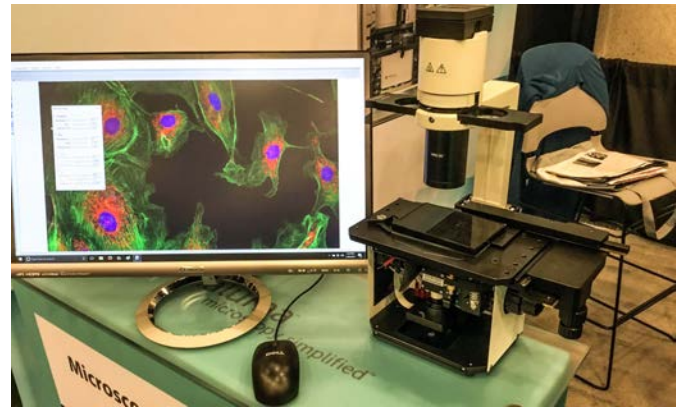
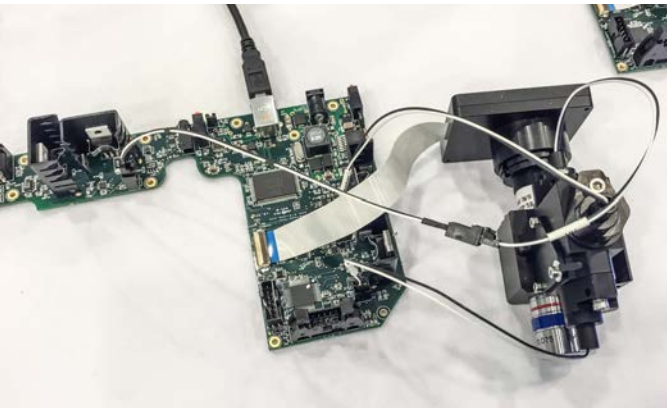

Etaluma's low cost OEM fluorescent microscopy head complete with three LED sources, excitation, and transmission filters, CMOS camera, and drive electronics (left) for around \$12.2 K OEM price. See related article on page 21.

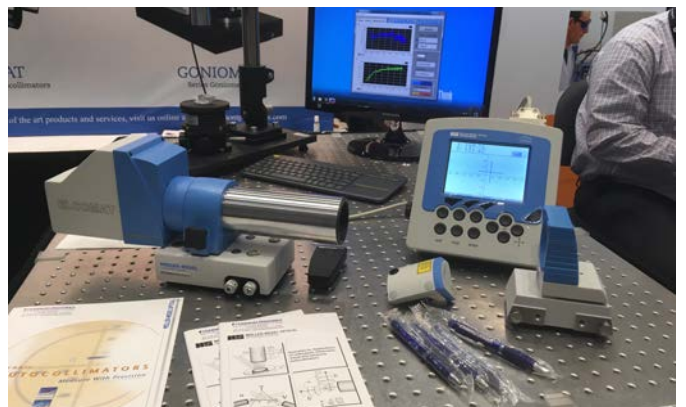

Vermont Photonics offers precision autocollimators, geometrical optics testing, and fine glass reticules.

New Micromax Tube System for Optoform



M23.2 X 0.75 Thread

25 mm

After introducing the new Optoform line in Laser Munich, and Photonics West this year, I thought without Micromax, the new Optoform line would really be dysfunctional. Optoform system relies on internal focusing of lenses rather than the old fashioned rail type focusing utilized in Microbench, and Thorlab's cage system. So an elaborate tube based system is needed to support the new design. That's how the new Micromax came about.

Micromax depends on, and lives off of the natural tendency in a user's mind to interconnect mounted optics, and mirrors in every way possible. All 25 mounted op-

tics in Optoform system have the standard Microbench M23.2X0.75 thread. So do all the tubes, and accessories in Micromax, including its interconnecting sphere 25-116, that has four mounting faces with this thread, and two more mounting faces with W0.8x1/32 microscope objective thread (opposite page).

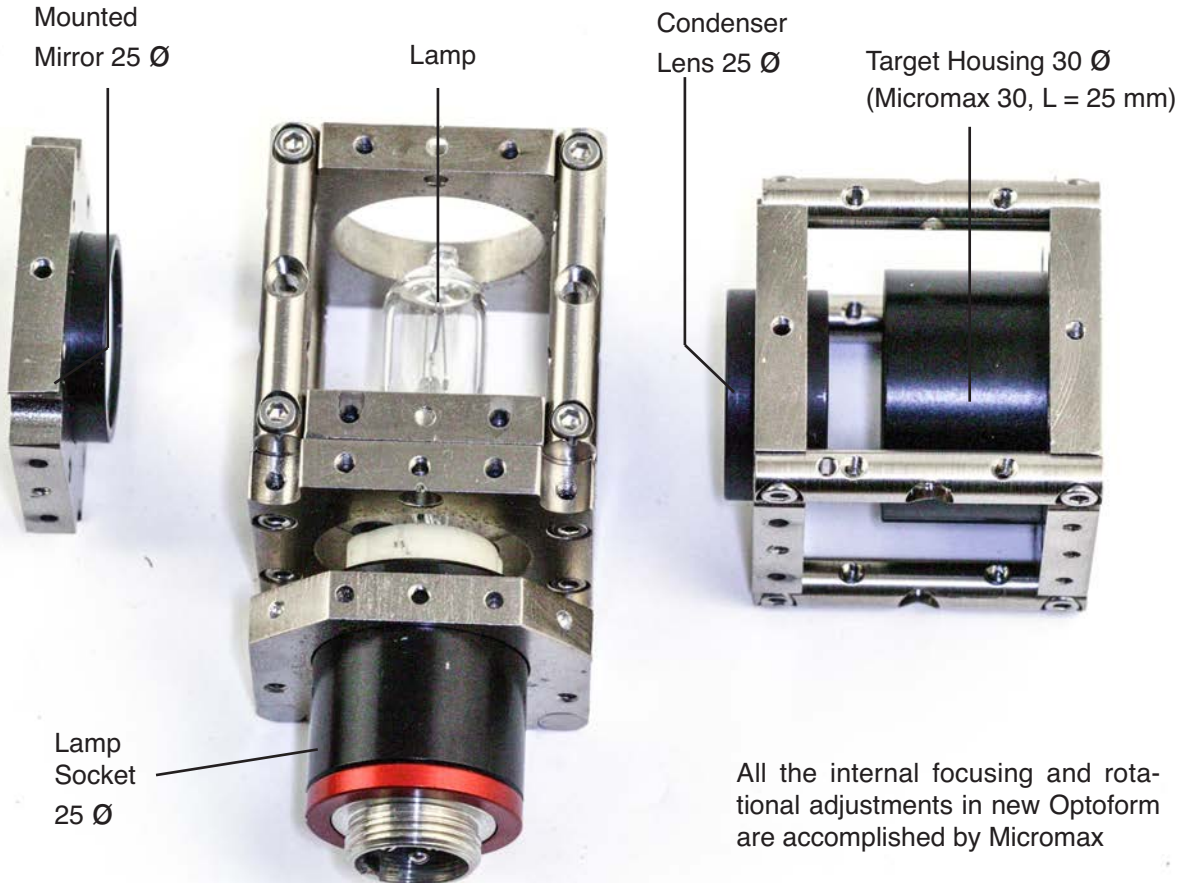

Mounted Mirror 25 Ø

Lamp

Condenser Lens 25 Ø

Target Housing 30 Ø (Micromax 30, L = 25 mm)

Lamp Socket 25 Ø

All the internal focusing and rotational adjustments in new Optoform are accomplished by Micromax

M23.2 X 0.75 Thread



Mounted lenses with engraving are the most easy to identify, and easy to use assets in a lab. The question is what would be the easiest way to utilize them? Optoform has the solution: The new Micromax connecting tubes, and accessories.

To build a small telescope, for example, tubes, eyepiece holder, and mounted objective lens cells are pieced together as desired. The eyepiece holder in this case allows focusing adjustment for the eyepiece. Note the orientation of achromats in their 25 mm lens cells: The threaded mount for longer lens (i.e., $f = 140$) is oriented towards the eyepiece, allowing its direct mounting to 25 mm tubes for constructing telescopes. The threaded end for shorter achromats (i.e., $f = 40$) are oriented away from the eyepiece, more for close focus applications. To utilize this lens in a telescope, a connecting ring 30-452 or accessory holder 25-198 is employed.



Above, combining Micromax 30 with Micromax 25 components to construct a short telescope. Right, a compact telescope built with Micromax 25/30.

An Autocollimator Built with new Optoform

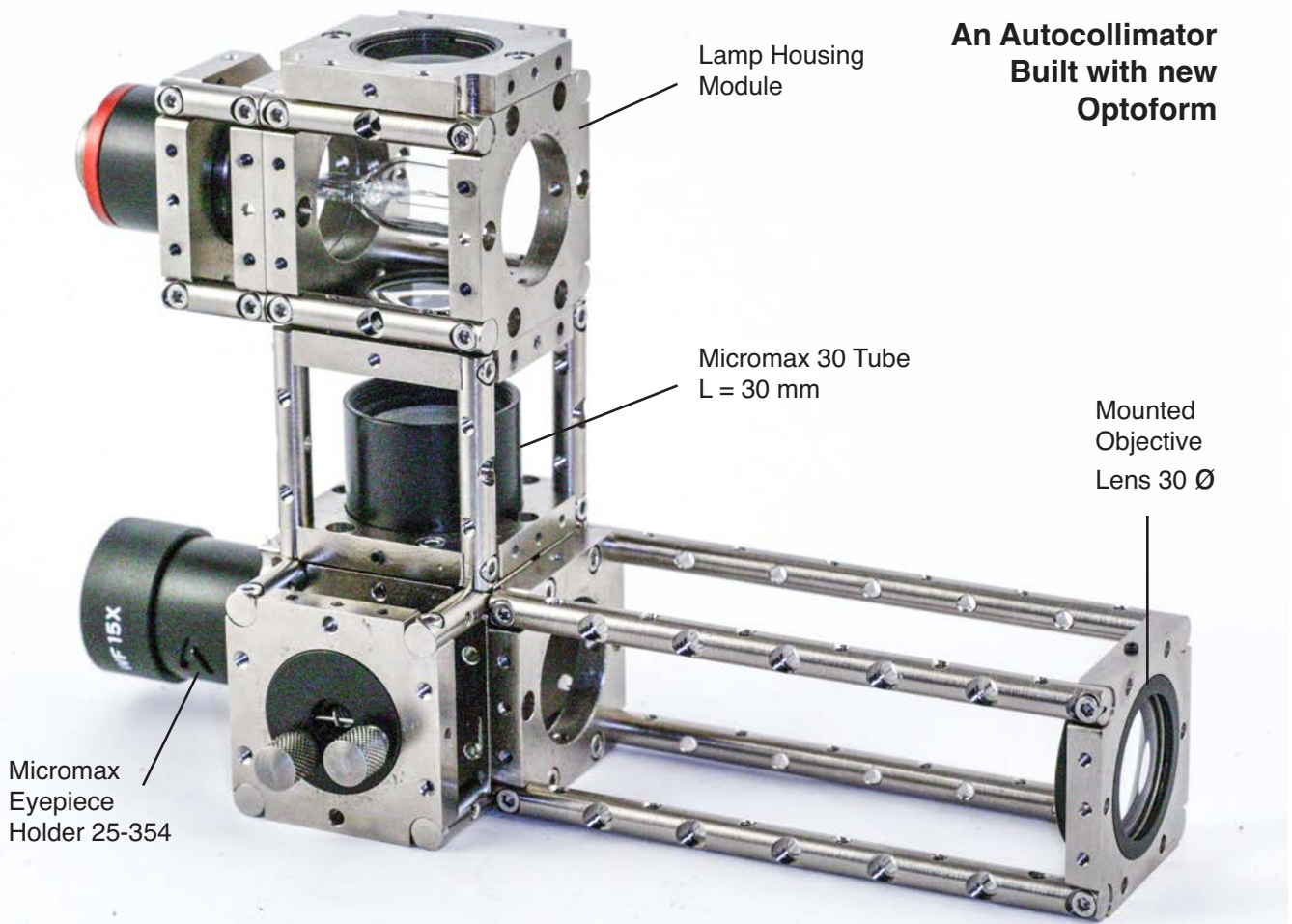

Tube System for New Optoform

So as the new Optoform will be expanding in new larger sizes (like Optoform 80, coming soon), new Micromax lens mounts will be available to support the optics. The next question would be could Micromax be utilized to build its own assemblies? The answer is yes, Micromax can be utilized to make complete light sealed assemblies.

There are two main advantages in the tube system of this type: Focusing, and rotation capabilities are built into each and every piece in the system. Tube systems have one more inherent advantage: As the tube diameter increases, so does the wall thickness. The end result is a self holding optical assembly that may be put aside for later use, and it is completely protected from dust entering its housing. The current range of Micromax sizes are: 25 mm (M23.2x0.75), 30 mm (M28x0.8), 35 mm (M33x0.8). These will all fit into Optoform 40. For Optoform 80, there is tube 60 (M54x0.8) with mounting rings for 40, 50, and 50.8 mm diameter optics.

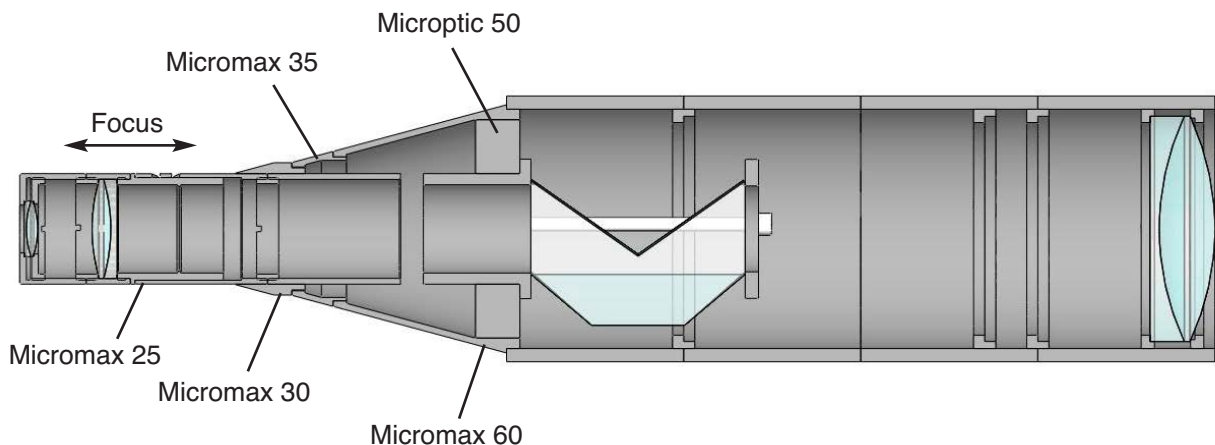

Spotting scope built entirely with Micromax

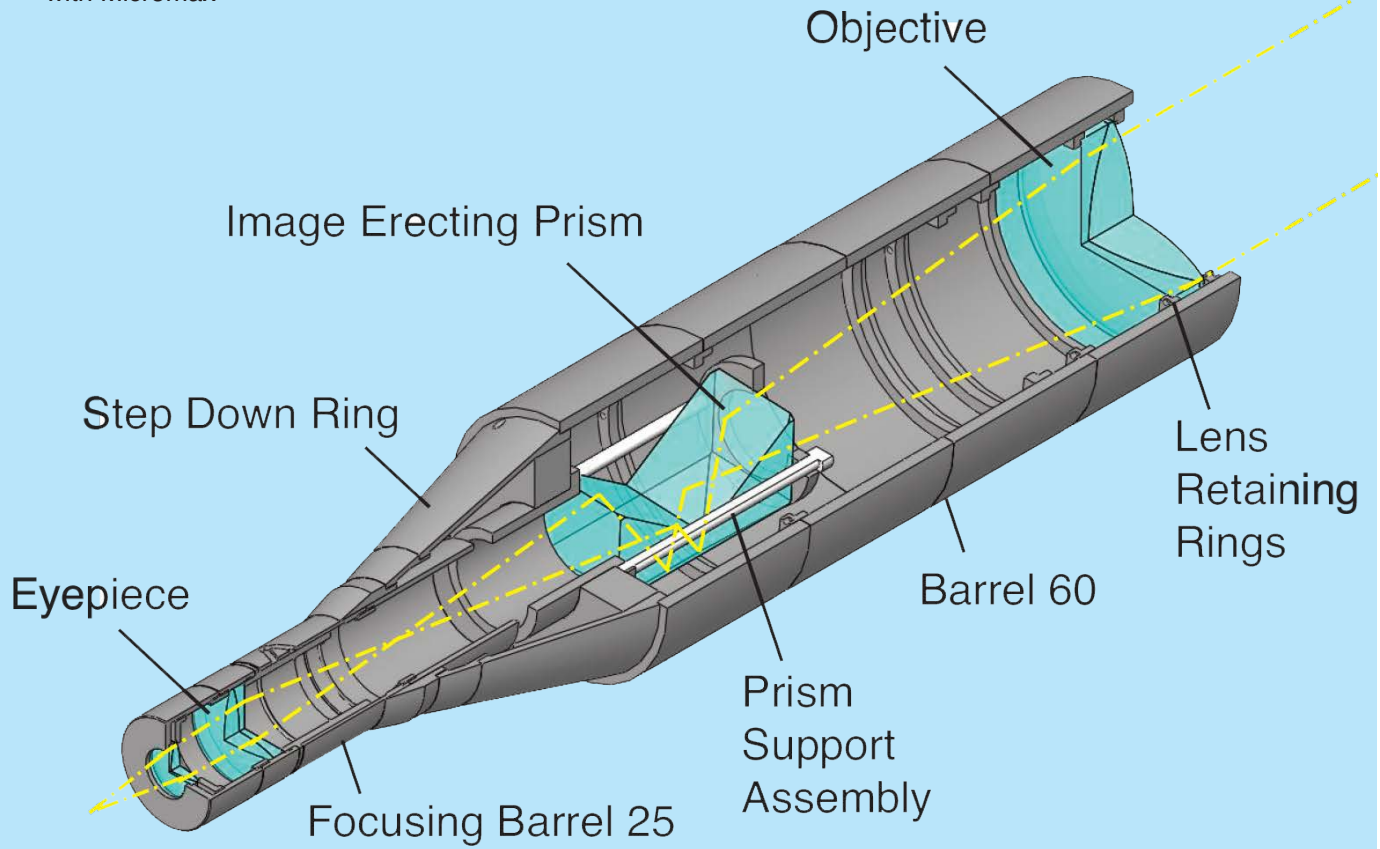

New Optoform assemblies can be put together by using already assembled modules rather than discrete parts.

My reunion with SPIE

By Ali Afshari



Sue Davis, courtesy Lincoln Harbour Photography

SPIE staff who have been organizing the SPIE shows (not including many others I haven't met or know less about):

Sue Davis

Event Planner Michele (Johnson) Bennet

Roberta Hart

PW Show manager

Michele (Johnson) Bennet

Senior Exhibitions Manager

Diane (Thompson) Cline

Events Manager at SPIE

Sara Burns

Exhibition Coordinator

Peter Halet

Director of marketing and industry relations

Returning to Photonics West as an exhibitor brought back many memories for me from the past. I remember in my first year in business, I had completely run out of funds but I still wished to be exhibiting at a show like Photonics West. The year was 1995, and a week before the show, during a visit to the Bay area, I met a lady from a low income family whose son needed a computer. It was there, and then that I decided to give her boy one of the only two computers I had. I came up with this story that a German company had given me a computer to display their products at the show but I really didn't have any other use for it. I said I could only use it at this show, and they could have it if they wanted it. This was the silliest story I could come up with but to someone in need, no stories sound silly.

I gave the boy the better looking computer I had. The rest went like magic for me: My car had broken down but a lady rented me a car on her credit card so I could drive from Southern California to San Jose. When I arrived at the show, Michele Thompson, who was the events manager at the time, greeted me with open arms, and gave me a table at a good location, and without asking, she said they'll just be sending me a bill later! A friend of mine saw me at the show, and invited me to stay at his house, so I had to cancel my never booked hotel reservation. Needless to say, my sales sky rocketed that year. On our way back, my brother invited us to dinner at a fancy restaurant, and I didn't even have to pay for my salesman's after the show dinner!



Having breakfast with Jack Schumann (left) now Co-Chair of Optics Valley, Arizona Technology Council. His life story as a businessman convinced me that all of us who come to these shows have far more in common than we could imagine. Standing is Peter Halet, the tall man who makes you feel tall with his support, and complements. Many warm hearted SPIE staff gave us what we are now giving back.

Right, exhibition coordinator, Roberta Hart is giving insights about Photonics West 2020 at exhibitor planning breakfast. This event was usually held in a big private room but this year it was held at the show floor. Although it drew more people to the event but I think it lacked the concentration it had in the past years. The SPIE president John Grivenkamp's presentation was very short, and useful.



Michel Bennet



Diane Robinson



Sara Burns



Peter Hallett

My machinist was Armik Amirkanian (an Armenian), my Lawyer was Paul Ware* (an Afro-American), my patent draftsman was Mel Gonzales (a Hispanic), my photographer who produced the first images for my catalog was Chester Maharaj (an Indian), my first salesman was Ali Sanagooy (Persian), and a lot of technical help came from my Vietnamese friend Coung Dang. My first advertising agent was Patti Smith from Smith Miller More. I can't tell you how fun it is looking back to those years, and the fulfilling relationship I developed with those who helped me succeed. Sue Davis lead SPIE to what it is today, and the most gratifying memory is while showing my product on a table-top SPIE had offered me at half price, I felt I had the same voice as the big guys. We were all invited to sit together at their exhibitor planning breakfast to share our ideas for the next show, and to make new friends.

One of my favorite books in business is "The magic of thinking big", by David Shwartz. When we think big in business, we'd better embrace the success of many others, or we might just end up looking at city lights from a high rise building with no one left to talk to. Without the help of Armik, Chester, Paul, Mel, Diane, Michel, Sara, Roberta, Sue, Ali, Coung, Patti, and that boy, and many others that crossed my path, I would have had so little joy, and my life would have been far less meaningful. I now have great stories to share when I am invited to give talks to students.

The secret to success is not having just good ideas, but it's your mindful effort. As an inventor, I agree more with Thomas Edison's definition of invention than any one else. Einstein says imagination is more important than knowledge, and I think that's still in pre-practice stage. Edison's definition of invention is more real (the 99% perspiration part). Just like 25 years ago, I now have a new invention, and while speaking with Jack Schumann (opposite page), he told me why not go back to Edmund, and sell your new idea to them like you did 7 years ago? I said the world is full of great ideas that no one wants. I told him about the inventor of sewing machine, barbed wire, and Xerox copy machine. He smiled



back at me, and couldn't agree more. The company who bought his product line, forgot all about their commitments shortly after signing the M&A agreement. They just put it aside, and never used it.

Back in 1994, I started my company with less than \$3,000. My Optoform invention had over 300 parts to be produced. That meant I had a \$1 budget to produce, and market each part! I think that would have been a good business plan to open a dollar store. I pushed my product for 10 years until I began making any profits, and I literally made most of those parts by hand. I am much wiser now, because my new invention has less than 25 parts to make but like most start-ups, I still have the same barriers when it comes to raising money. Back then, Newport offered me \$45K for it. That reminds me of a Persian poem by Freydoon Moshiri called the musician:

A poor musician had nothing but his old guitar, so he took it to the market to sell it. Today, you'll find these musicians at corners of Market street in San Francisco. No one saw the value of that old instrument, and out of pity, someone offered him \$3. He was so hurt by that offer, so he started polishing the instrument with his shirt, and began tuning it. As he tuned the strings, he heard each, and every note so pleasant to his ears. He began playing the instrument with all his passion, and longing. The whole marketplace stopped to listen to two old companions rejoining each other with such love, and devotion. Someone offered \$1000! Surprisingly, the two companions did not want to be apart from each other. The last line of that poem reads: When talent joins hands with true willpower, the whole world falls at your fingertips.

Back in those days, \$1000 was a lot of money. Today, people speak of billions. If you search for any idea in Google, you'll always find something useful that no one ever uses. That's really not the fault of a product. A product is like the flower "Little Prince" fell in love with, as foretold in the beautifully animated movie, based on Antoine De Saint Exupery's book. As he explains in that book, the flower tames you for the time you spend with it, and by your efforts to fulfill its wants, and needs. If you have a product that you truly believe in, but you are not pursuing it, you haven't been empowered as a child. When you have a strong desire to succeed in your product, don't listen to anybody who tells you it can't be done. Do it with honesty, and full commitment. You'll live a life of passion, and will be happy seeing your product out-living yourself. You'll also find SPIE is there to help you!

*You could look up my documentary "Paul Ware, a Life in Patents" on youtube if you would like to learn more about patents.



Prism Award Ceremony. Courtesy, Hary Tagat, in sales at Edmund Optics.

Low cost solution for fluorescent microscopy Part I

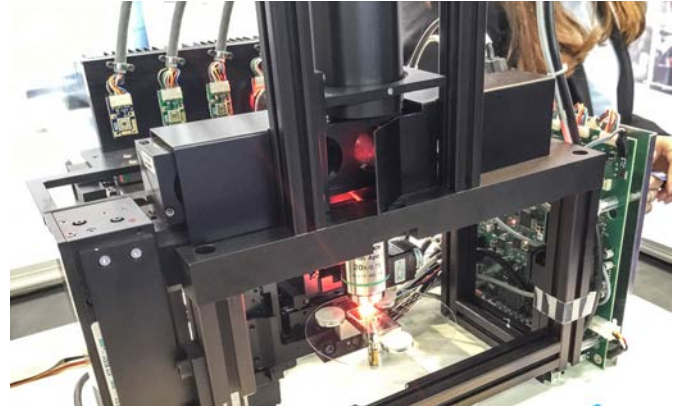
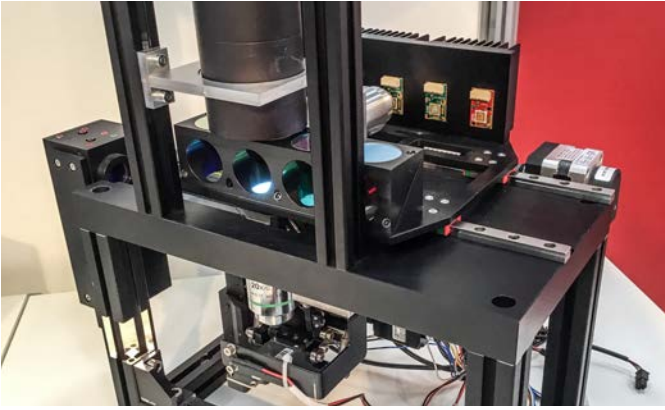

Automated inverted fluorescent microscopes (above) are expensive to build. In addition to X-Y-Z sample positioning, and focusing stage, they also utilize more motorized stages for changing filters, sensors, light sources, objectives, etc.

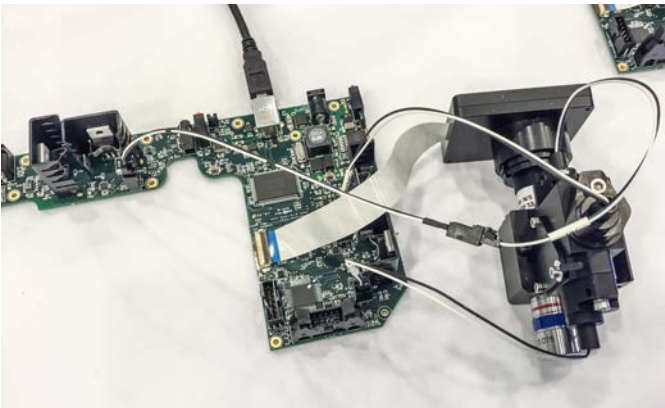

Setting up fluorescence microscopy has been in high demand at various university labs. The input to every image analysis software that is being developed at university research groups still needs good optics. Some labs are also invested in fully automated setups, requiring motorized stages to scan a multiplicity of samples, requiring far more sophisticated control software, as well as image processing software.

Etaluma, a small firm in San Diego has been offering an OEM module for small labs to develop their own hardware, and software. It is a fully integrated 3-LED light source, with built-in filters (no moving parts), and camera head, capture board, and LED driver electronics. Etaluma also offers complete fluorescence microscopy solutions either with manual or fully automatic motorized version for research labs who are developing their own image analysis software.

Etaluma's OEM fluorescent microscopy heads complete with three LED sources, transmission filters, CMOS camera, and drive electronics cost around \$12.2 K in quantity OEM price. With the 2-objective arrangement (right), the user has the option to have six filters, or three filters with two objectives, etc. email: eweiner@etaluma.com

Next installment: Integrating Etaluma's fluorescent head with Optoform

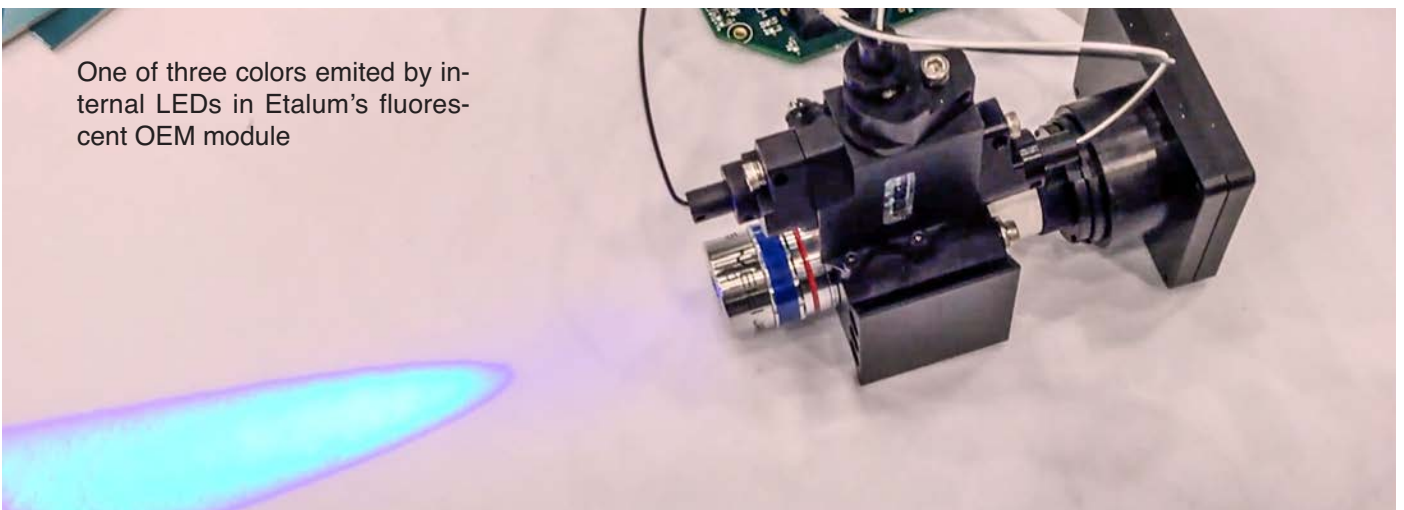

One of three colors emitted by internal LEDs in Etaluma's fluorescent OEM module

Chromic

Automatic Chromosome sorting software

Software features:

Costs under \$5k, compatible to most cameras

Online image capture and visualization

Convenient tools for editing metaphase images

One of the best image processing algorithms for enhancement of microscopic images

Last generation Artificial intelligence algorithms for classification of chromosomes

Provides powerful tools for separation of overlapping chromosomes

Exports a report based on examiner's comments on the test results

Optional motorized stage control for metaphase search, and image capture



Competitive advantages of the software:

- One-year free access to latest software upgrades
- High quality and lower cost
- Personalization options for labs and users
- Technical support

