

Optomechanix

[Zeiss Axioplan Microscope](#)
[Brief History of Zeiss Design](#)
[Design elements of Axioplan](#)
[Zeiss Axiovert Design](#)
[How to talk to God](#)

Ziess Axioplan/Axiovert Microscope design Review

Sep - Dec 2025



Technical journal of OMiD, Opto-Mechanical Institute of Design

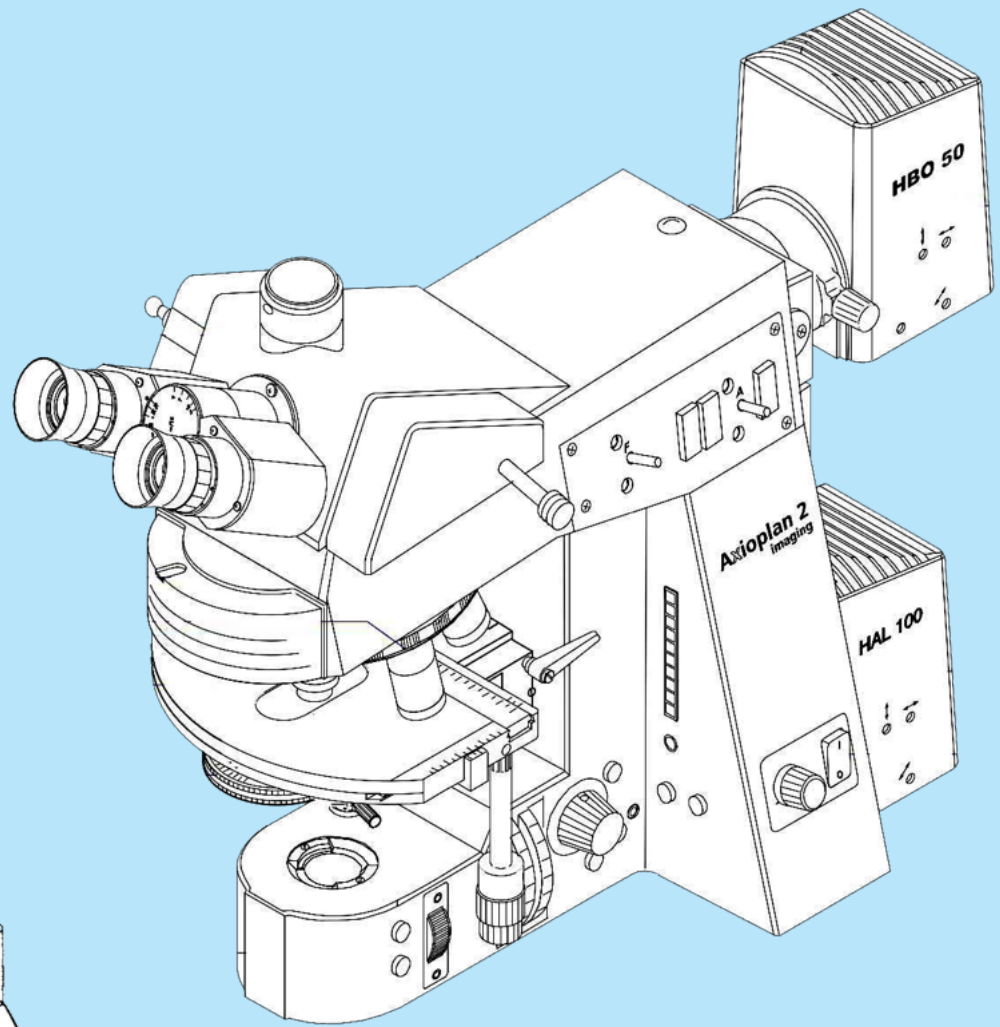

Axioplan 2

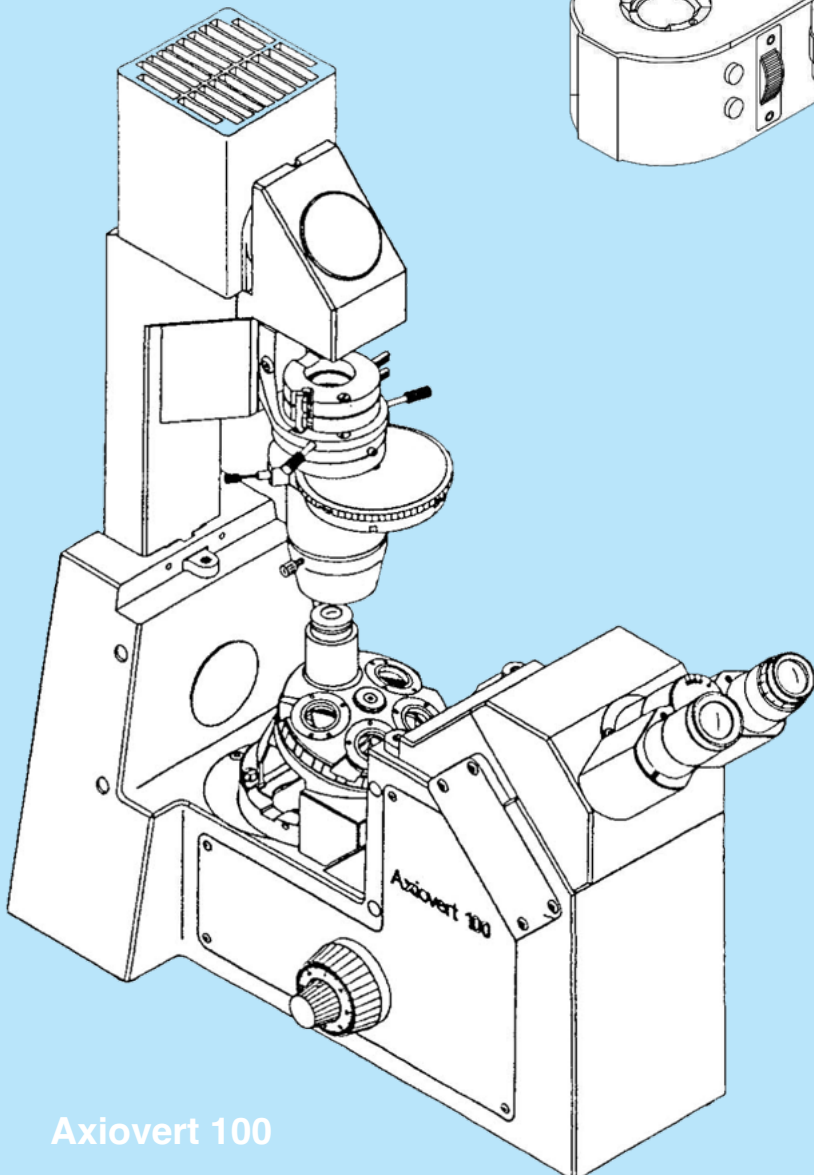

Axiovert 100

Contents

Page

Introduction	3
Zeiss Design Group, a Brief History	4
Axioplan Design	6
Development of Axioplan	8
Utilizing the Zen Software	15, 22
Development Cost of Axio Series	19
Axiovert Design	30
Zeiss Designers of Axiovert	35
An Essay on Gaza: How to Talk to God	36



Rachel Corrie, peaceful activist

national Solidarity Movement (ISM). During the Second Intifada in the early 2000s, Rachel Corrie traveled with a group of ISM activists to Gaza to protest the Israeli occupation. On March 16, 2003, Rachel was killed by an Israeli bulldozer as she stood between the bulldozer and a Palestinian home to prevent its demolition. The event featured Rachel's parents, Cindy and Craig Corrie, and was moderated by the Executive Director of the Jerusalem Fund, Jihad Abusalim.

Today, so many journalists have been killed in Gaza with state justified reasons that they no longer need to erase the footage of security cameras. They have complete unaccountability to drop their masks, and do their horrific acts for the whole world to see.

This issue Dedicated to:

Rachel Corrie (1979-2003), From Rachel Corrie to **Aaron Bushnell**: sacrificing for Palestine. "I think it is a good idea for us all to drop everything and devote our lives to making this stop. I don't think it's an extremist thing to do anymore."- Rachel Corrie, 2003. "Compar03ed to what people have been experiencing in Palestine at the hands of their colonizers, [this] is not extreme at all."- Aaron Bushnell, 2024

On March 22, 2023, The Jerusalem Fund held an event to commemorate the 20th anniversary of the death of Rachel Corrie at the hands of the Israeli regime. Rachel Corrie was an American human rights activist and a member of the Inter-



Above, Rachel standing in front of Giant Caterpillar bulldozer wearing her bright orange color jacket at the time of her death. Right, Rachel's parents in court. 20 years ago, they sued Caterpillar for selling bulldozers to Israel, an action Palestinians could have never been in a position to take.



Copyright 2025

Web: www.optomechanix.org

Instagram: [optomechanix](https://www.instagram.com/optomechanix)

For digital subscription or suggestions email us at:

info@optomechanix.org

Chief Editor: Ali Afshari

Web Designer: Mojtaba Moradli

Optomechanix is a quarterly journal of Opto-Mechanical Institute of Design (OMiD), with technical articles for practical, hands-on opto-mechanical engineers. This magazine is privately founded.

Cover page photo: A meadow inside palace grounds where I stayed for 3 days in city of Ramsar, northern Iran.

All drawings are courtesy, Carl Zeiss, adapted to explore industrial design of Axioplan 2, and Axiovert 100.

In This Issue ...

In the last issue, we covered a professionally made interferometer designed by Jon Buccini. I intended to follow up on that issue to show how it could be built with Optoform. In spite of my good intentions, my ideas reflected in this magazine were being copied by my competitor, and their design team got all the credit for much of my work. So I concluded to stop covering Optoform until it reaches full production. However, I will continue my articles on Optomechanics.

The design I have picked to discuss is one of Carl Zeiss's best: The Axioplan 2, and Axiovert 100. There is so much to learn from its industrial design. It took me eight school years studying physics, mechanical engineering, optics, and then electronics to finally figure out my real passion was industrial design. The word I came up with to narrow it down to optical engineering was Optomechanix. Very few optical engineers pay attention to industrial design, simply because they haven't had the right tools to explore it. The solution I have been offering for past 30 years has been Optoform.

Ironically, if you search Wikipedia, the name Optoform has been taken over by "Cage System". I wrote an email to Wikki to bring it back. Optoform isn't going anywhere, it's here to stay. I covered the confocal AxioPLAN 2 (LSM 510) back in July-Sep 2021 issue of Optomechanix, and showed how it could be built with Optoform. We'll be looking at the microscope itself in more detail more through the eyes of industrial design.

Ali Afshari
Editor in chief
Optomechanix

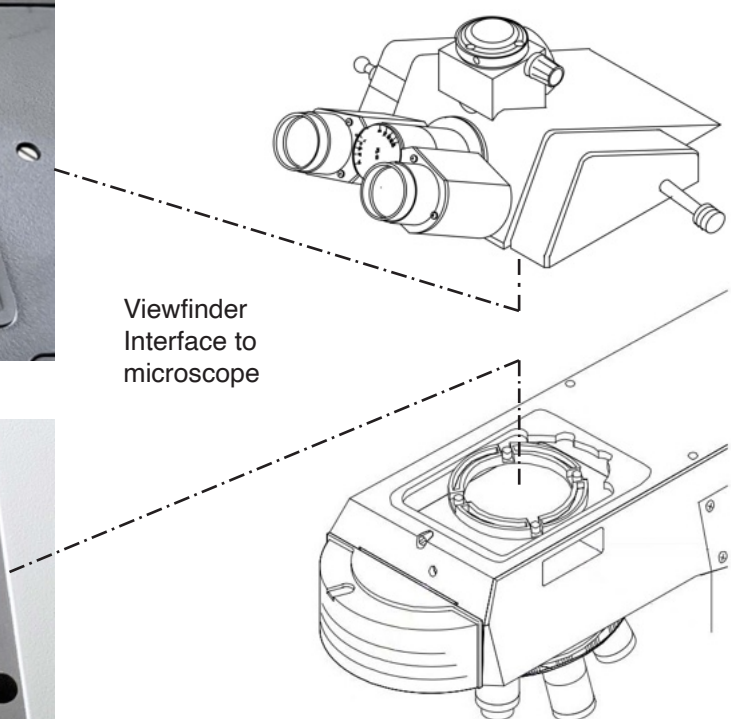
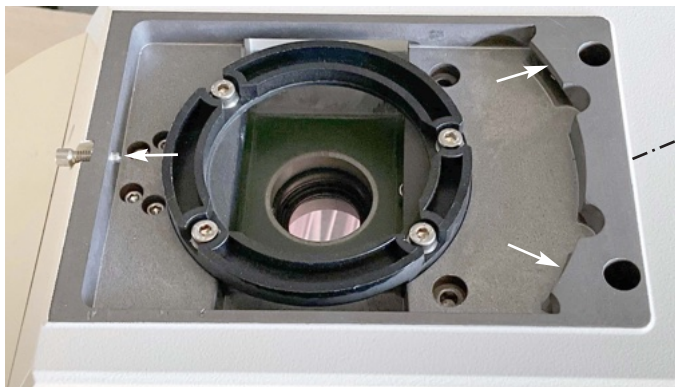
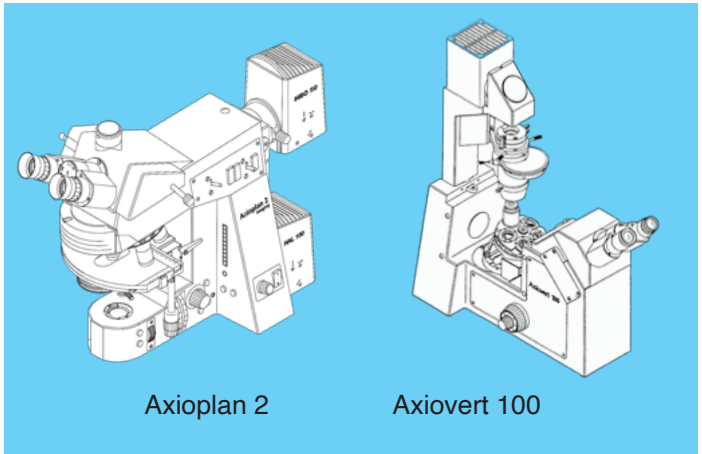

The dovetail interface between the viewfinder, and the body is usually a complete circle. With the introduction of Axioplan, Zeiss announced: It doesn't have to be. In this case, a huge dovetail interface has been achieved without the circle.



Zeiss made a huge effort to develop their line of microscopes, these are just to name a few:

Name	Role / Contribution	Notes
Dr. Hans-Joachim Haase	Optical designer (ICS system dev.)	Credited in Zeiss internal docs and patents on infinity-corrected optics, chromatic compensation, and modular optical trains.
Dr. Winfried Denk (later of Max Planck & Janelia)	Worked briefly at Zeiss on optical concepts before developing 2-photon design pathways.	Influenced high-NA DIC and fluorescence microscopy (early 1980s)
Dr. Dieter Gerlach	Project manager for microscope sys.	Involved in Axioplan and Axioskop mechanical & optical integration.
Dr. Peter Siedentopf (Zeiss optical designer, 1950s–70s)	Designed predecessors (Standard, Universal); many design principles carried forward to Axioplan.	

Design outsource: Zeiss Axioskop, and Axiovert series. Industrial Design Office (headed by **Hartmut Esslinger's** firm, **frogdesign**, in consultation 1980s) Helped establish the smooth modular "Axio line" visual language seen in Axioplan,

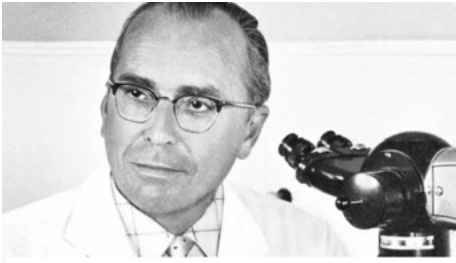

1943

Device for microcinematography: Under the direction of Kurt Michel, the first film on cell division is produced in a "micro" laboratory with the aid of a phase-contrast microscope.
Photo: © ZEISS Archives



1955

Launch of an all-new photomicroscope with integrated camera and automatic exposure control.
Photo: © ZEISS Archives



1973

Axiomat, a microscope with unparalleled stability and image quality
Photo: © ZEISS Archives



1986

ZEISS unveils a new generation of microscopes – the "pyramids": the design includes special features of the Axioplan, Axiophot, and Axiotron: ICS (Infinity Color Corrected System) and SI (System Integration).
Photo: © ZEISS Archives



2003

The ApoTome imaging process allows high-quality, economical optical sections to be produced by means of biological samples marked by fluorescence. In the same year it won the R&D 100 Award
Photo: © ZEISS Archives

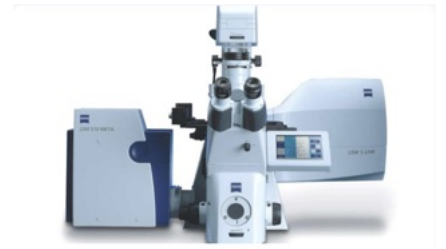

2005

The LSM 5 LIVE, a light microscope, with which living cells can be examined 20 times faster and in a particularly gentle manner, enters series production in Jena and receives the R&D Award for its performance in real-time research.
Photo: © ZEISS Archives

Historical landmarks of Carl Zeiss progress from their website; Top right, Zeiss Universal's design was extraordinary.

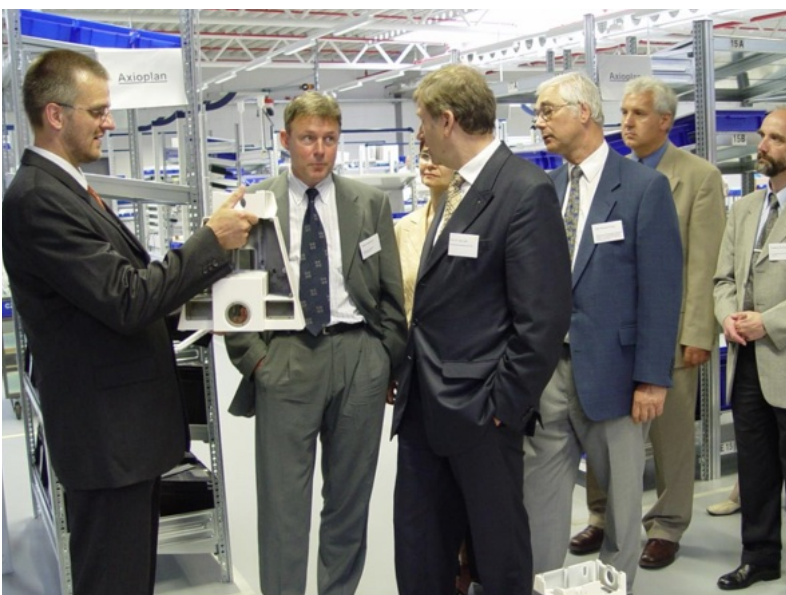

Axioplan 2 housing held by a Zeiss employee in 2003 in a new 2500 square meter assembly facility in Konigsalle.



Axiovert microscope being assembled, and tested.

The Zeiss Axioplan Line, a brief history

I would first like to tell you that I won't study anything and present it to you unless it is beautiful. The purpose of Omid museum is to study all the most beautiful optomechanical works from around the world. Zeiss has most likely spent a fortune in developing the Axio series. Starting with their Universal model Zeiss left behind their curved body design to cubical, and with Axio they utilized rectangular form, and what a clever intuition.

Industrial design is so necessary to explore by optomechanical engineers, and that what's so missing. While I'm studying these forms, I also keep in the back of my mind: Could we do it with Optoform? Back in the July-Sep 2021 issue of Optomechanix I showed that yes you can. I built a much more advanced version of this microscope (the LSM version with confocal scanning head) from scratch by using off the shelf Optoform pieces. In any case, just look how gorgeous this design is (right). In their Universal model, also covered in that issue Zeiss couldn't deliver what they had in mind without mechanical impediments.

You see the toughest choice in designing an expandable system is the distance between the turret, and the condenser (right). You need to fit the sample platform with focusing stage, a focusable Abbe condenser assembly, and a huge choice of obje-

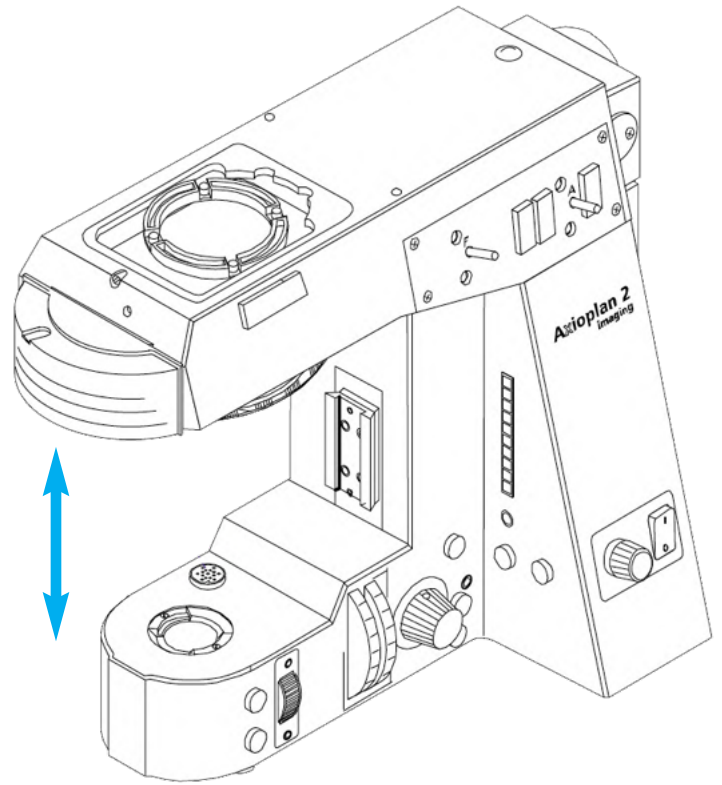

When a microscope is designed to accommodate future expansion, the most calculated decision is the height of its nose-piece turret. It should allow a huge number of arrangements.

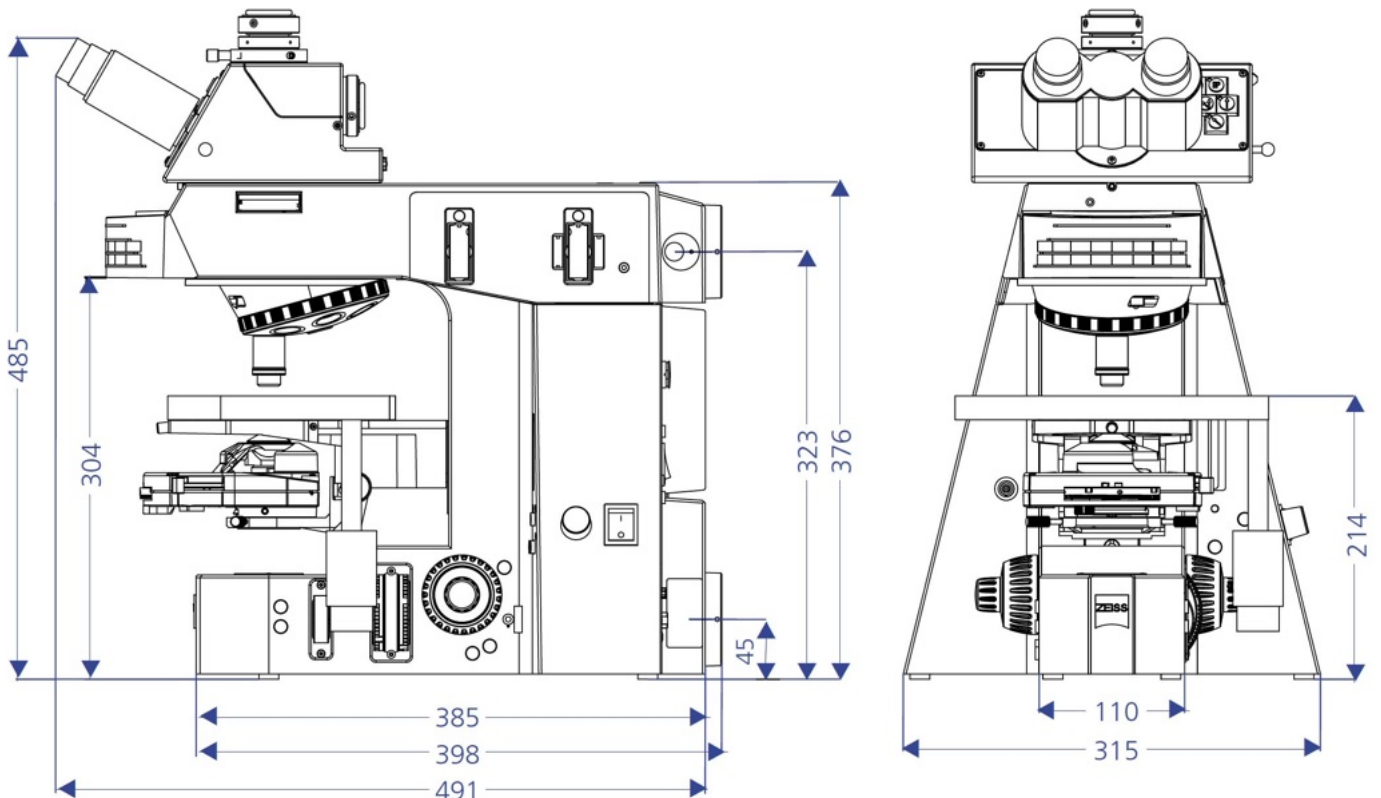



Beginning disassembly: Lamp mount, and reflector below



Lamp alignment fold mirror



Sample stage removed to reveal focusable Abbe Condenser

cives, that will require phase masks (for phase contrast) with centering capability, darkfield option with requiring special condensers, polarization condensers, etc. The turret itself should be able of handling DIC, phase contrast, bright field/darkfield objectives, etc. The illumination may need to come from above (incident), and below (transmission), with various light sources like Halogen, Mercury, Xenon, some requiring filament alignment while installed on the microscope. The observation head must accommodate several accessories beneath it such as an autofocus unit, magnification changer, and as shown in case of Zeiss, the capability to add a scanning confocal attachment with a laser or pressure lamps as its source. Zeiss has handled them all in this half a meter tall, 23 Kg housing. It is a monster compared with other microscopes of its time. Still smaller than its predecessor, Zeiss Universal. With these designs, Zeiss displayed no reluctance to offer new designs with no fears of size, and weight.

Looking at the housing, the power supply fins are cleverly placed in between two entrance apertures of the microscope (left). We'll disassemble this housing to see its internal layout. The advantage Zeiss had in this design was its motorized components. This allowed control buttons to be placed anywhere around the microscope. To come up with these designs, Zeiss employed a clever group of designers, many of whom are unknown to most people. We explored Zeiss design team briefly in the last two pages.

Brief History

The Zeiss Axioplan microscope represents a pivotal evolution in the field of optical microscopy, combining high-performance optics with innovative modular design to meet the growing demands of scientific research. Over the course of its development, the Axioplan series has undergone significant technical advancements, expanding its capabilities and applications. The microscope series has been instrumental in improving microscopy techniques in diverse areas such as cell biology, materials science, and medical diagnostics.

We'll begin with the technical history of the Zeiss Axioplan, exploring its origins, key design milestones, and its evolution into one of the most renowned names in modern microscopy.

The Origins: Zeiss' Commitment to Precision Optics

Zeiss, founded in 1846 by Carl Zeiss in Jena, Germany, has been a pioneer in optical technologies for over a century and a half. By the mid-20th century, the company had already established a strong reputation in the development of microscopes, Telescopes, optical lenses, and precision imaging systems.



Back View, with power input, and Computer serial interface



Back View, with power supply outputs

tems. The company's focus was on producing optical instruments of the highest quality, which would later culminate in the creation of the Axioplan line.

1) Early Developments in Microscopy (1950s–1980s)

Before the Axioplan series, Zeiss had already introduced several significant innovations in optical design, such as fluorescence microscopy, and phase contrast microscopy, which allowed researchers to observe live cells and organisms without staining. Zeiss microscopes became an essential tool in research labs, particularly in cell biology, medical research, and microbiology.

During the 1980s, the technological landscape was rapidly changing with the increasing demand for higher magnification, improved image resolution, and multimodal imaging. These developments led Zeiss to design a microscope series that would push the boundaries of optical performance while offering enhanced flexibility in configuration.

2) The Introduction of the Axioplan Microscope (Late 1980s)

The Zeiss Axioplan was introduced in the late 1980s as a stand-alone upright (Axioplan), or inverted (Axiovert) microscopes specifically designed to meet the growing needs of both academic research and clinical diagnostics. The name "Axioplan" was derived from the microscope's "axial" optical system and its planar (flat)

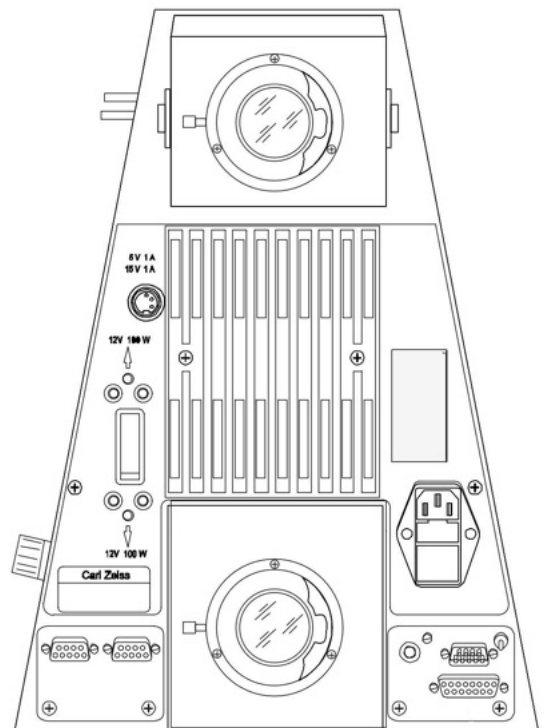

Back View

field of view, which represented a significant step forward in the optical design of microscopes.

Key Features of the Original Axioplan:

Planar Optical System:

The Axioplan's most innovative feature was its planar optical design, which ensured that the image remained sharp and even across the entire field of view. Traditional microscopes often suffered from field curvature, where the image became distorted at the edges of the field. The Axioplan solved this issue by integrating plan objectives—lenses that ensured flat, distortion-free imaging across the entire field.

Modular Design:

The modular configuration was a breakthrough for microscopes at the time. The Axioplan could be easily customized to accommodate various imaging techniques, from brightfield to phase contrast, and later to fluorescence and DIC (Differential Interference Contrast) mi-

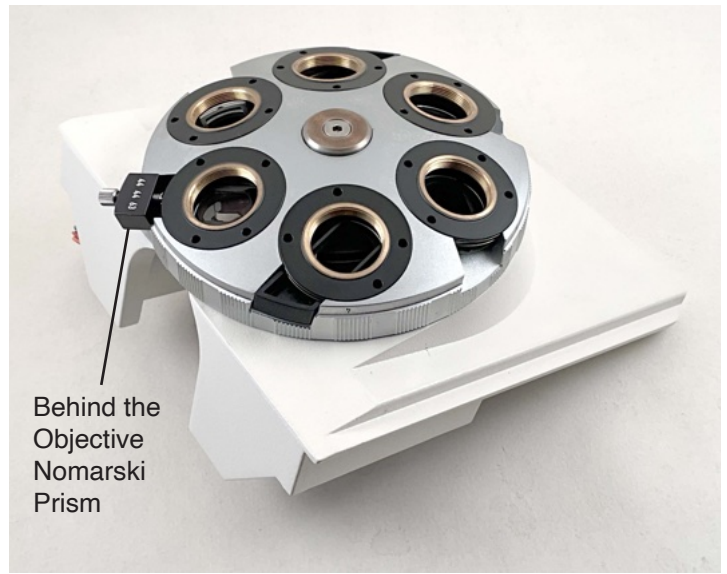

Behind the Objective Nomarski Prism



DIC, Fluorescent, and Phase Contrast objectives

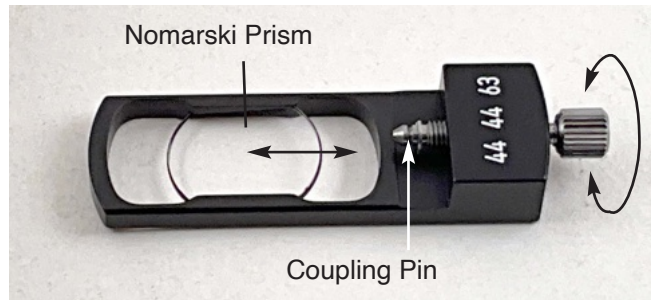

DIC filter engages via a coupling pin to the turret

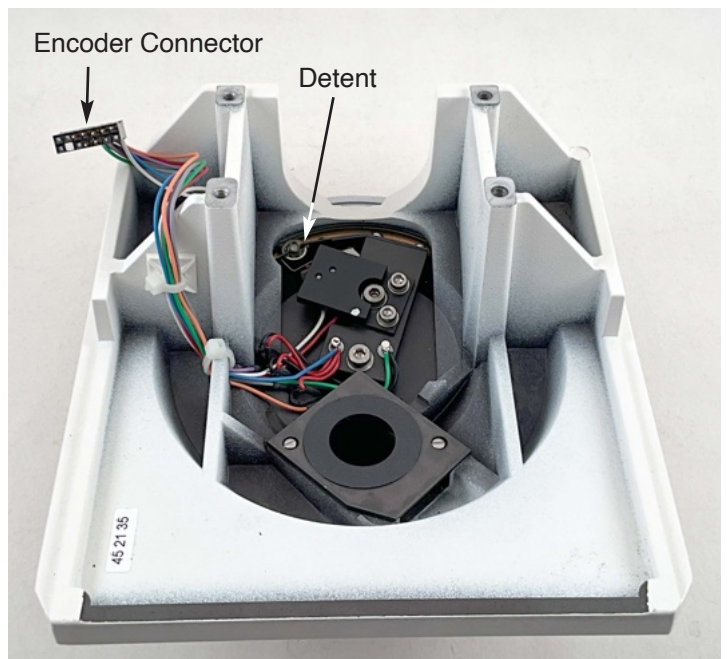

Objective turret encoder cable is to be disconnected during interchange.

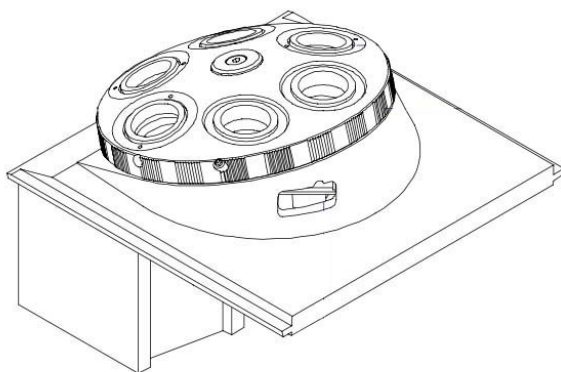

Various nosepiece turrets are available for Axioplan. It is held via 4 (M4) screws located on top of the housing.



croscopy. This flexibility was achieved by allowing users to swap out the optical components, such as objectives, condenser systems, and filter cubes.

Fluorescence Imaging:

With the increasing need for fluorescence microscopy in biological research, Zeiss developed a fluorescence attachment for the Axioplan that allowed users to perform multi-channel fluorescence imaging. This was a significant leap in scientific research, as it enabled researchers to track different biomolecules using various fluorescent dyes and observe their interactions in live cells.

Enhanced Illumination:

The introduction of an advanced illuminator system was another key feature of the Axioplan. It allowed for both transmitted and reflected light microscopy, which was essential for studying a wide range of specimen types, including thick tissues and live cells.

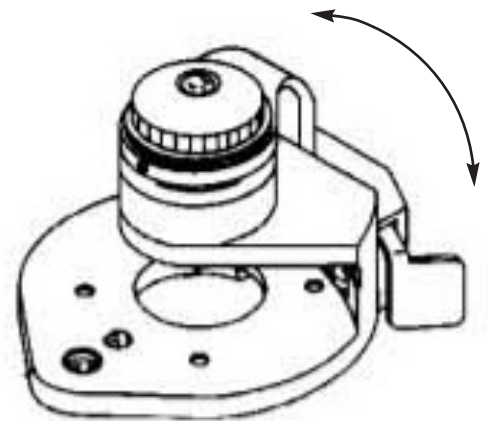

The condenser attachments in Zeiss Axioplan 2 are cleverly designed. There is a ball bearing detent (below) to set correct positions for outer control ring, and a convenient switching lever that couples with the swing-in condenser. Interestingly, condenser filter carriers are interchangeable.

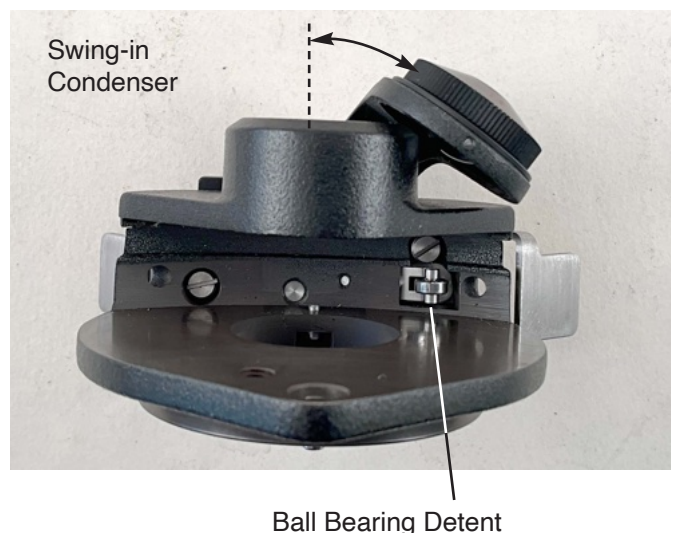
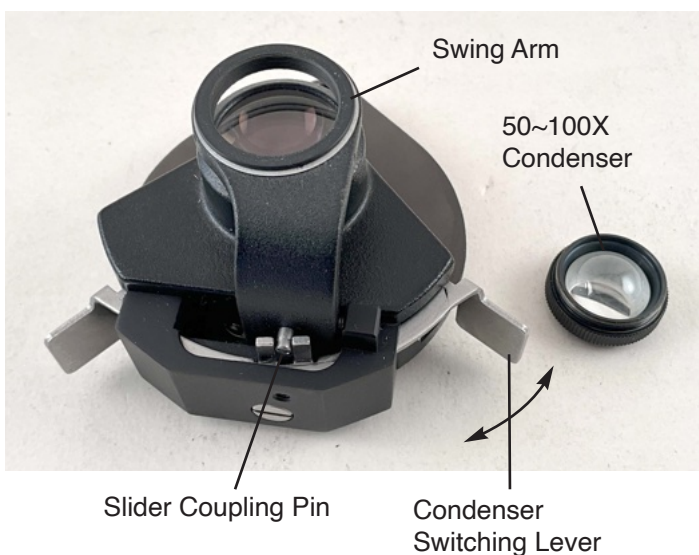

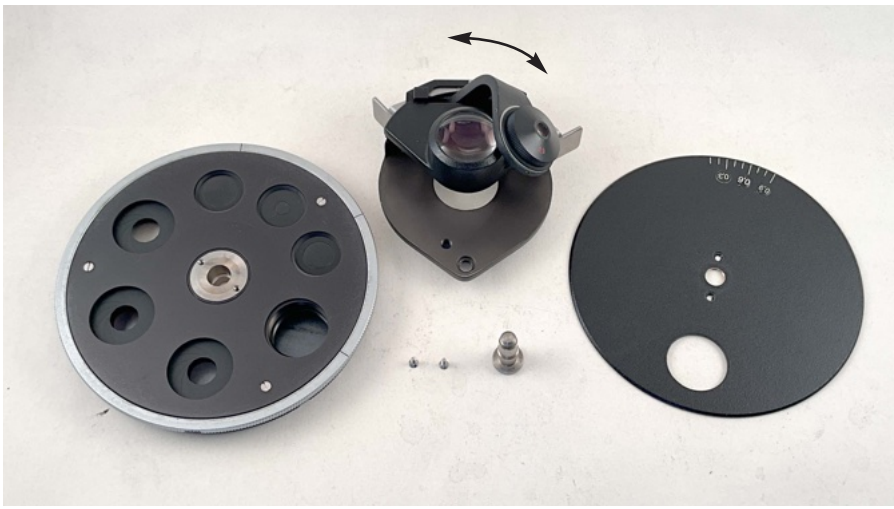

The Axioplan quickly gained traction in research institutions, due to its performance in both routine laboratory applications and cutting-edge fluorescence microscopy.

3) The Zeiss Axioplan 2 (Early 2000s)

The next major milestone in the Zeiss Axioplan series came with the release of the Axioplan 2 in the early 2000s. This upgrade was the result of significant technological advancements in optical design and user-centric improvements. The Axioplan 2 expanded upon the features of the original model while introducing innovations that would shape the future of microscopy.

Key Upgrades in Axioplan 2:

Enhanced Optics: The Axioplan 2 introduced apochromatic objectives, which corrected chromatic and spherical aberrations across a wider range of wavelengths. This was especially important for high-resolution imaging and fluorescence microscopy, where the separation of spectral signals is crucial. These objectives delivered sharper, more precise images with minimal distortion.

Motorized Components:

The introduction of motorized components was a game-changer. The Axioplan 2 featured motorized stage movement, focus control, and filter wheel selection. These motorized systems allowed researchers to automate image acquisition, reducing the time spent on manual adjustments and increasing throughput, particularly in high-content screening applications.

Improved Fluorescence Capabilities:

Fluorescence imaging continued to be a significant focus. The Axioplan 2 came with motorized filter wheels for rapid switching between different fluorophores, improving efficiency in multi-label imaging. The ability to

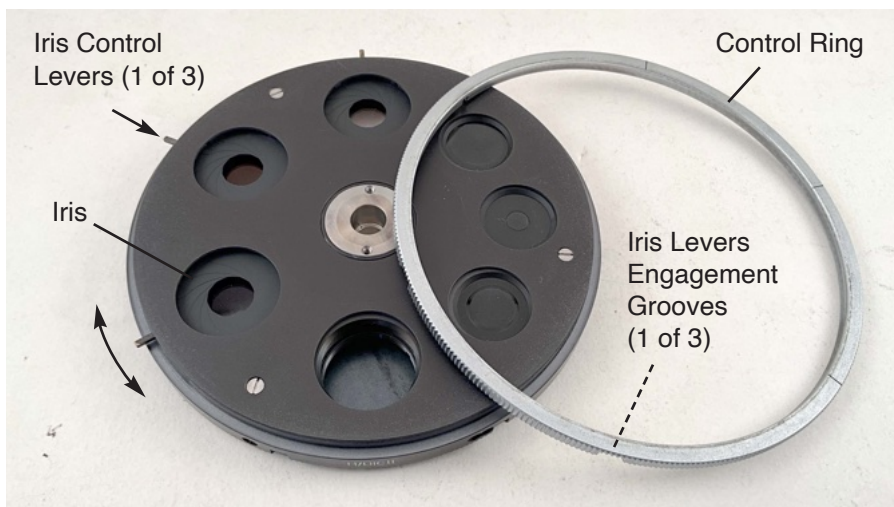

The outer ring acts as the rotary advance ring to set different filter positions, i.e., for three Phase contrast apertures or three condensers. Each condenser has its own iris diaphragm. Setting the iris diaphragms are accomplished by the same outer ring that is engaged with three separate aperture arms. Each phase contrast aperture is centerable via two fine screws 120° apart.

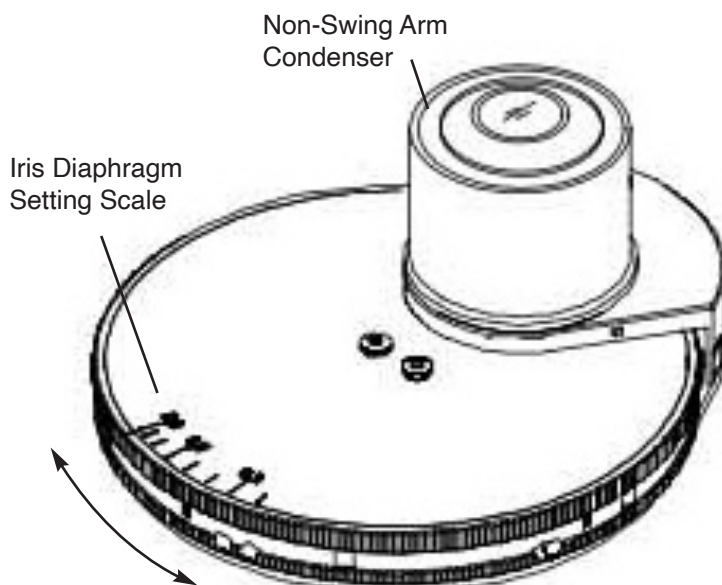

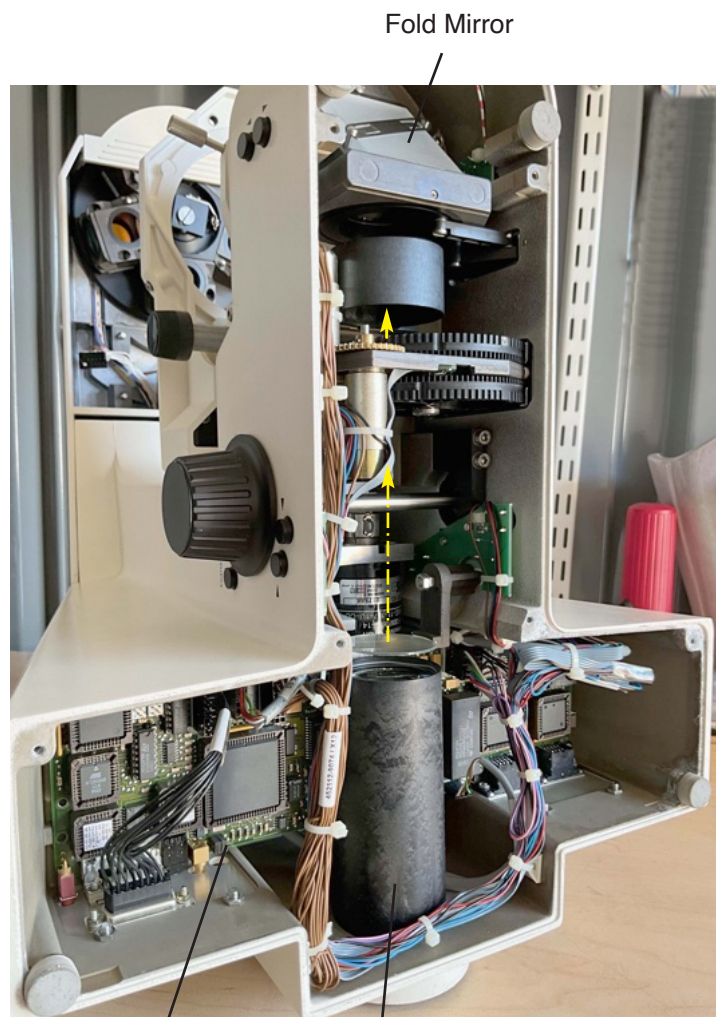
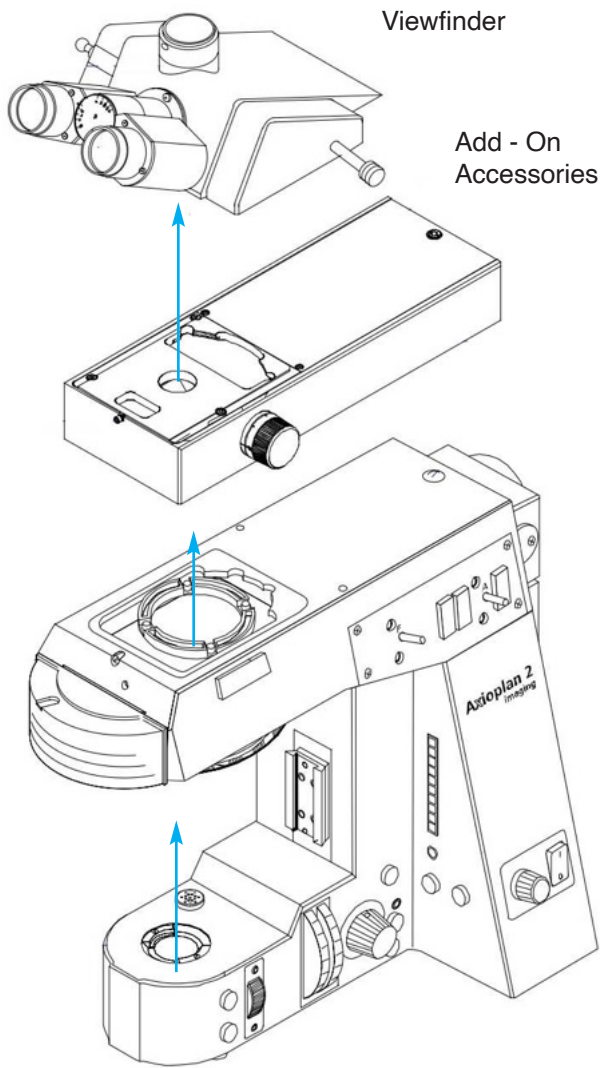

seamlessly integrate with digital cameras and advanced imaging software allowed for more sophisticated image capture and processing.

Higher Resolution Imaging:

The Axioplan 2 was designed to handle higher resolution imaging techniques, supporting the use of higher magnification objectives (such as 100x oil immersion lenses). This made the Axioplan 2 suitable for imaging smaller, more complex samples, including cellular organelles, subcellular structures, and nanoscale materials.

Flexible Illumination Systems:

The Axioplan 2 provided compatibility with a variety of illumination sources, including LED, mercury vapor lamps, and halogen lamps, which allowed users to choose the optimal light source for their specific application. The transmitted and reflected light systems could be combined with a polarizer and DIC prisms, allowing researchers to examine

Above, side view and lower view of illumination optical path in transmission mode

both live and fixed samples in a variety of contrast modes.

4) Technological Integration and Software Advances

As the Axioplan 2 continued to evolve, Zeiss recognized the need to integrate digital imaging systems and advanced software solutions into their microscope platforms. The development of the AxioVision and ZEN software suites was integral to this progression.

Software Integration:

AxioVision: This software enabled precise image acquisition and analysis, with tools for 3D reconstruction, image stitching, and quantitative analysis. AxioVision helped users manage large datasets, particularly in applications like high-content screening and cell tracking.

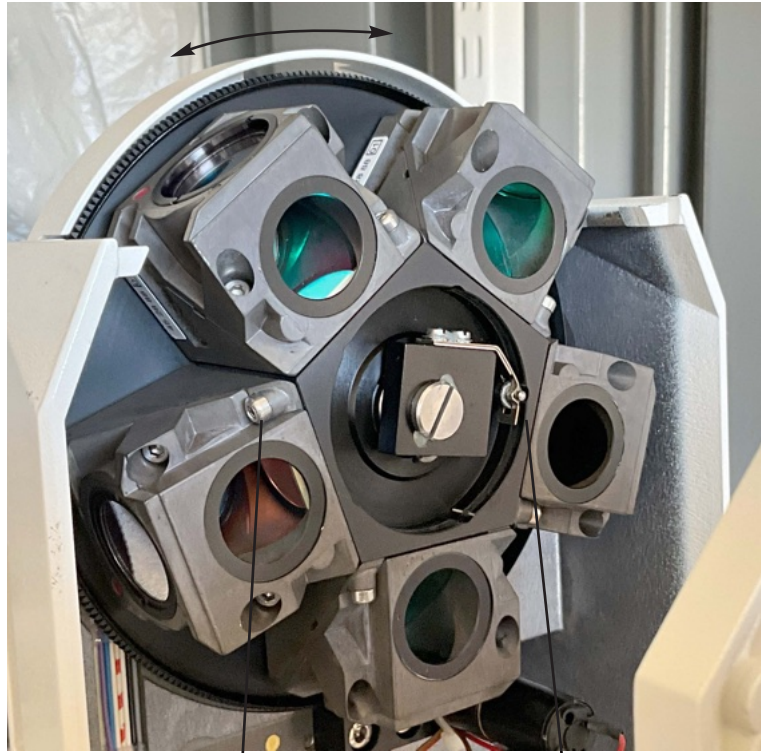

Beamsplitter Cubes Drive Motor Gear Cube Securing Screws Detent

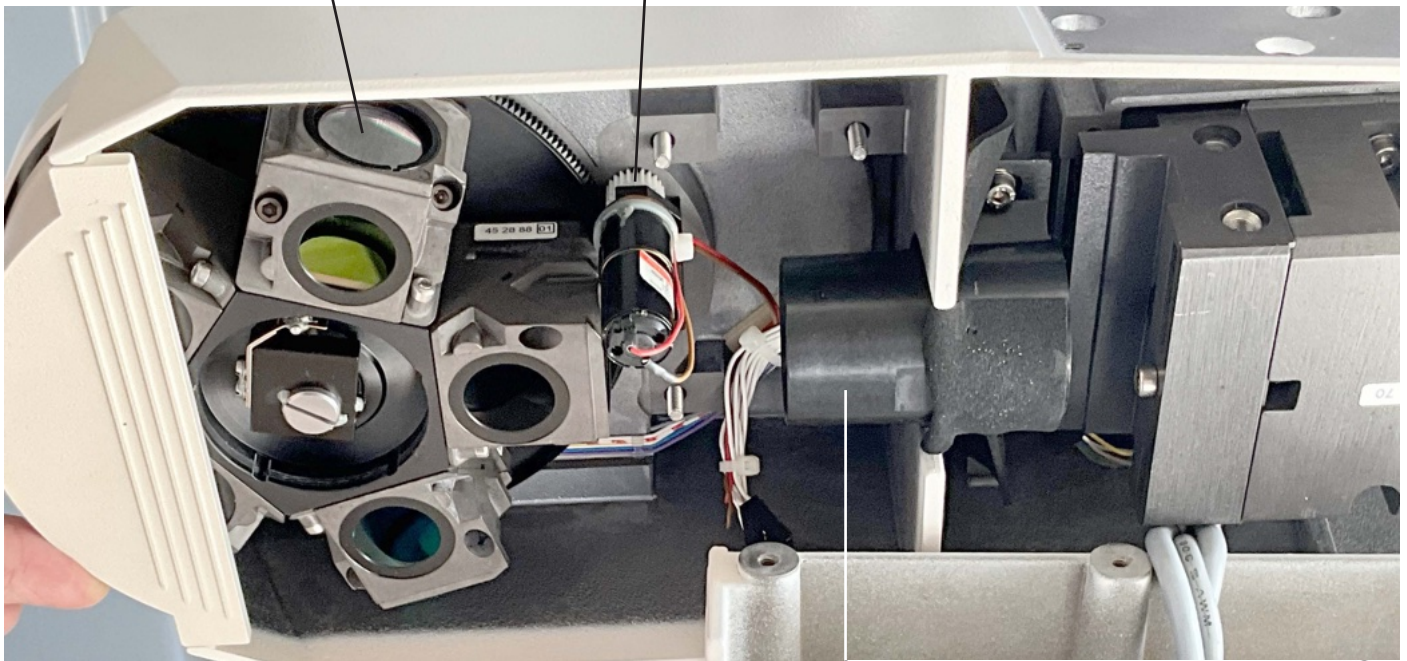

Incident Illumination Collimation Optics

ZEN (Zeiss Efficient Navigation):

ZEN offered a more modern interface for microscopy, supporting high-resolution image acquisition, live-cell imaging, and integration with other Zeiss imaging systems. ZEN also incorporated machine learning and automation features, enabling users to automate complex imaging tasks, such as z-stack acquisition and multi-channel fluorescence imaging.

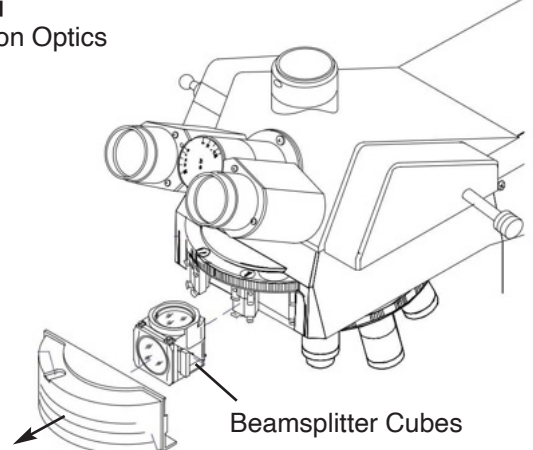

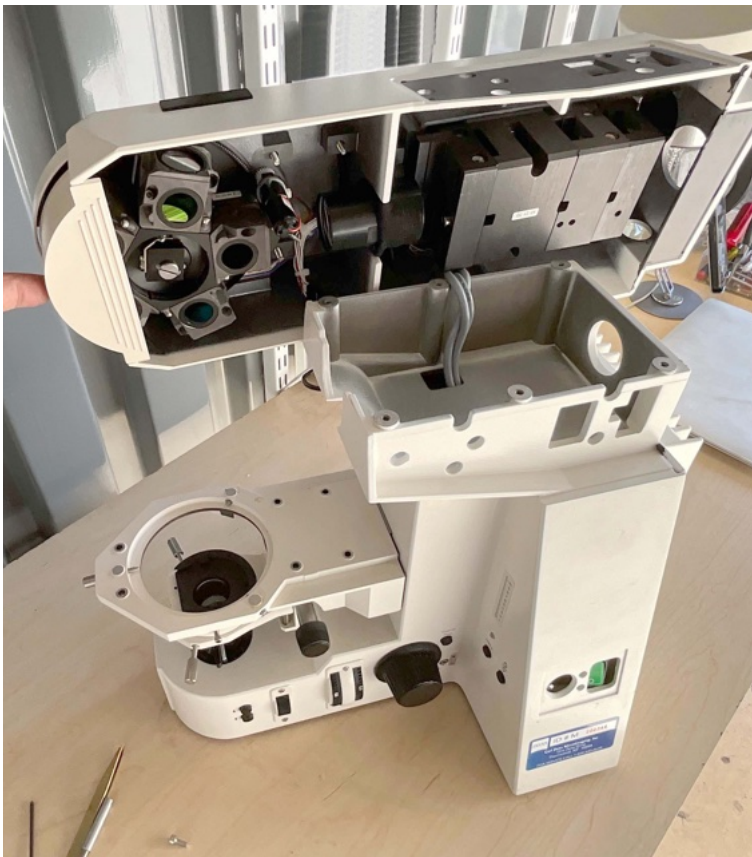

Two views of top cover removal: In Axioplan, the collimation optics is mounted on to teh top cover shell. In Leica, and Olympus, it is mounted on the main diecast. This choice is based on the rigidity of the top cover.

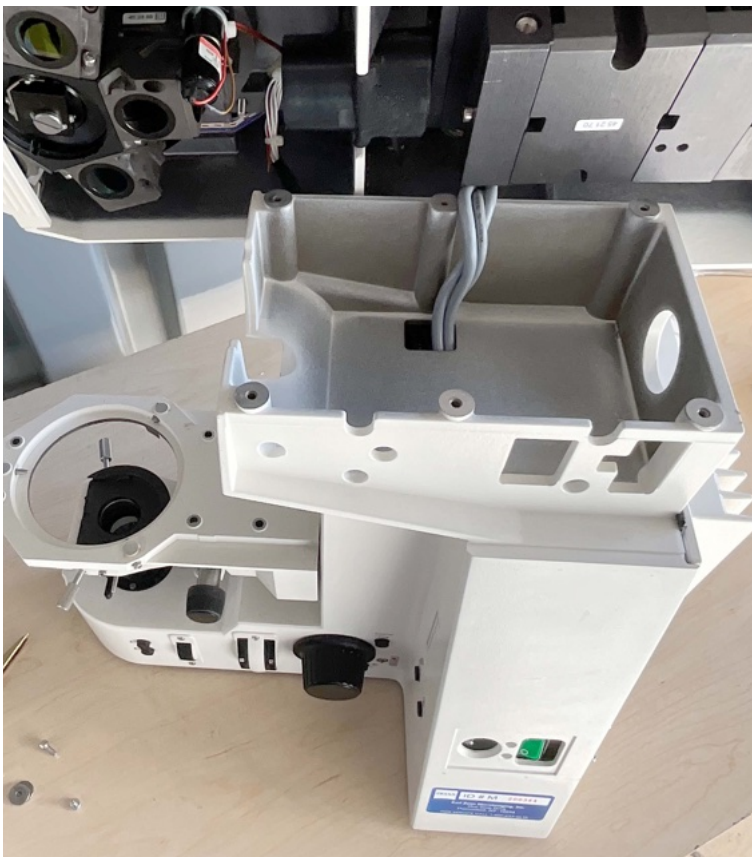

5) Axioplan 2 Imaging: Specialization for Advanced Imaging

In the 2000s, the Axioplan 2 Imaging model was released, a version specifically optimized for advanced fluorescence microscopy and live-cell imaging. The imaging model featured additional enhancements to support multi-dimensional imaging, including time-lapse, z-stacking, and multi-channel fluorescence. It was designed for researchers working in specialized fields such as molecular biology, neuroscience, and materials science, where the ability to observe dynamic processes in real-time is essential.

6) Current Trends and the Future of Axioplan

Today, the Zeiss Axioplan 2 remains an integral part of the Zeiss microscope lineup. While it has been succeeded by the Zeiss Axio Imager and other modern imaging systems, the core design principles of the Axioplan—modularity, optical excellence, and versatility—continue to influence Zeiss's approach to microscopy.

The Axioplan 2 has set the foundation for modern confocal microscopy, super-resolution techniques, and high-content screening platforms. Moreover, Zeiss continues to innovate in the field of fluorescence microscopy, digital imaging, and automated microscopy.

Technical Overview of the Zeiss Axioplan 2 Microscope Design

The Zeiss Axioplan 2 microscope represents the epitome of precision optical engineering and modular design, making it an invaluable tool for high-level scientific research. Released as a successor to the original Axioplan, the Axioplan 2 integrates numerous enhancements in both functionality and ergonomics, positioning itself as a versatile, high-performance microscope for a broad range of applications, including cell biology, materials science, and clinical diagnostics.

7) Optical Design and System Overview

At the core of the Zeiss Axioplan 2 is its optical system, which provides exceptional clarity and accuracy in a variety of imaging modalities, including brightfield, phase contrast, DIC (Differential Interference Contrast), and fluorescence. The microscope's modularity is evident in how users can easily tailor the optical setup for different imaging techniques and sample types. Several key design elements contribute to the overall optical excellence of the Axioplan 2.

A) Achromatic Objectives

The Axioplan 2 features apochromatic objectives, which are specifically designed to mini-



Setting the control software of Axioplan 2 to produce image stacks of micron sized pebbles (below) at 0.2 micron increments from -5 micron to +5 microns of the focus point. Performed by Nico Stuurman at UCSF, Howard Hues Medical Institute.

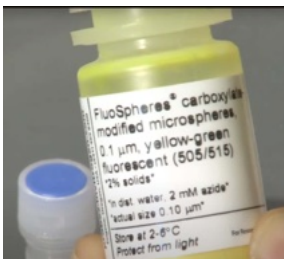

Measuring Point Spread Function of 1 Micron pebbles through Zeiss APO objectives. Using Axioplan's motorized focusing function 11 sample points may be imaged to choose the best focus plane.



imize chromatic aberrations across multiple wavelengths. This ensures that images exhibit exceptional color fidelity, sharpness, and contrast, even in the most demanding imaging conditions. The high-quality optics used in these objectives allow for greater resolution and reduced optical distortions.

The objective lenses are mounted on a reversed nosepiece, which not only makes it easier to switch between objectives but also optimizes the working distance, providing more room for specimen manipulation.

B) Corrected Optical System

Zeiss' use of achromatic and apochromatic correction ensures that spherical and chromatic aberrations are minimized across the entire visual spectrum. This improves the performance of the microscope

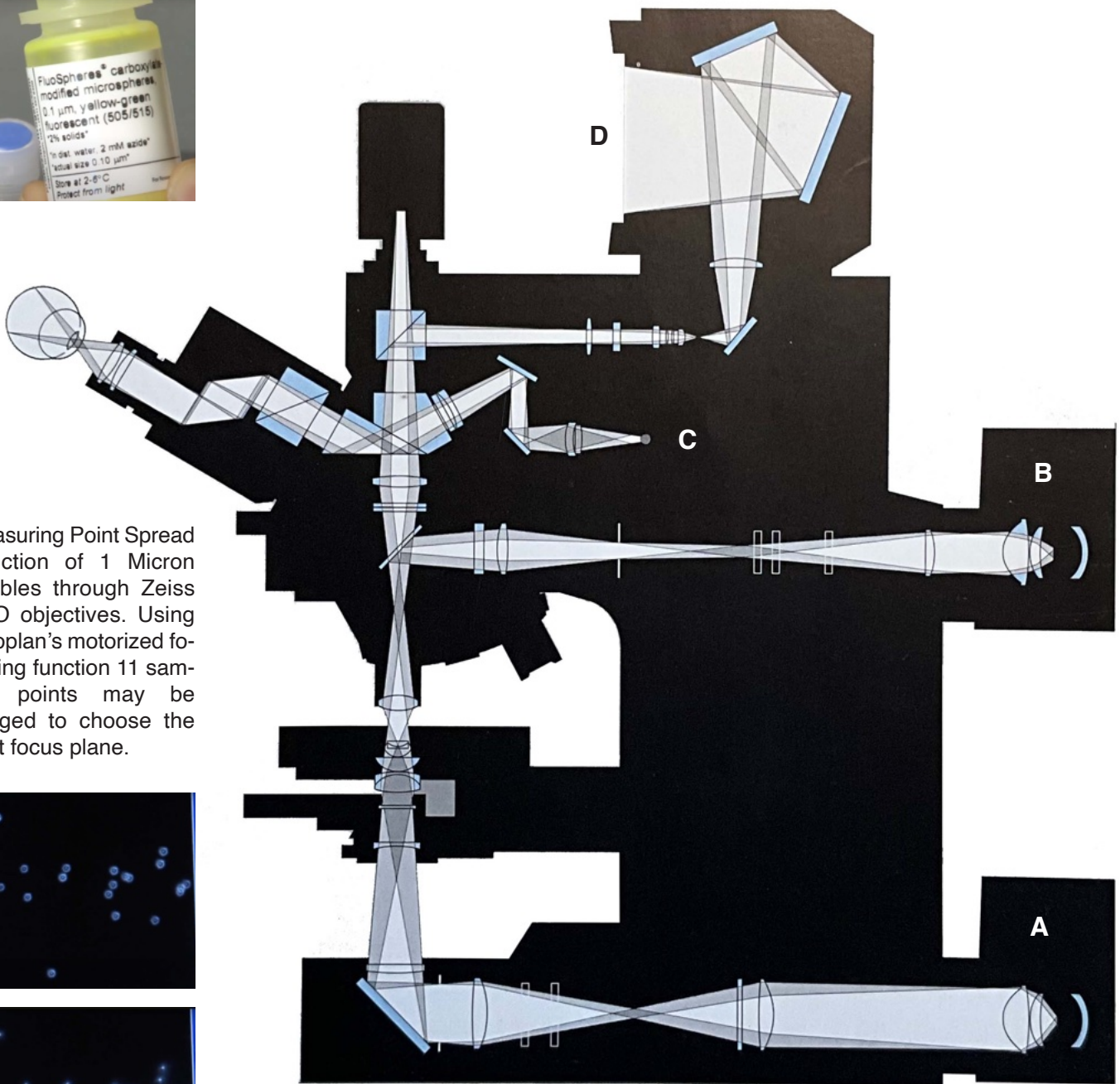

Alternative or simultaneous beam paths through Zeiss Axioplan 2 microscope From Below using light source A, or from above utilizing light source B. Light meter C was utilized to set proper exposure for a large format film camera D of its time.



Above, the most clever design I have seen in iris diaphragm control, basically linking two dials by utilizing a lever.

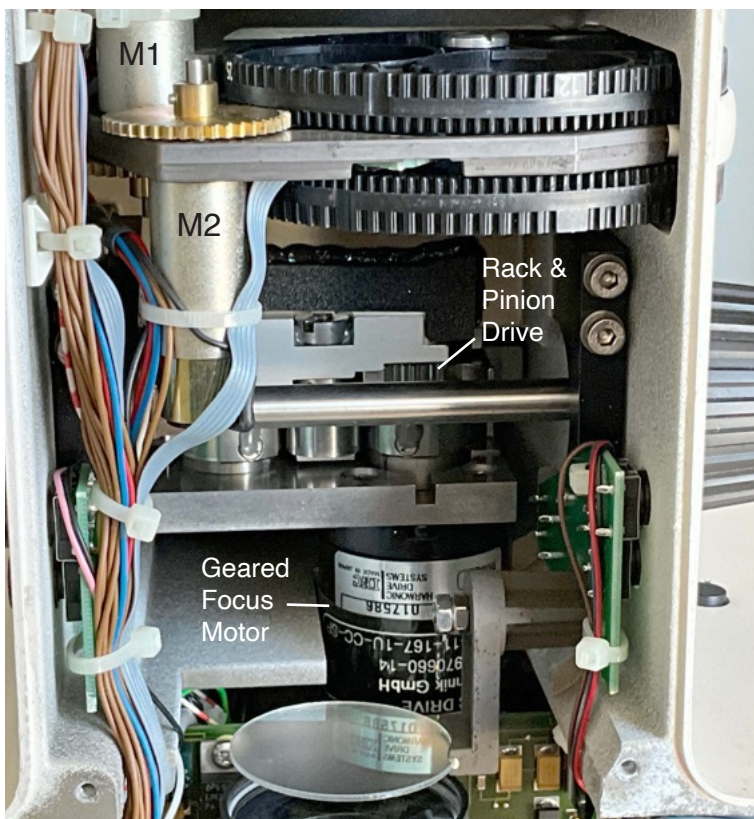

Motorized filter wheels can be preset to automatically advance during objective/filter cube change via geared-motors M1 & M2.

in applications requiring high levels of accuracy, such as fluorescence microscopy or high-resolution live-cell imaging. The Zeiss optics are designed to work seamlessly with the Infinity-Corrected Optics system, which ensures that the objectives' image planes are corrected at a single focal point, improving the clarity of images across the entire field of view.

C) Illumination Compatibility

The Axioplan 2 supports multiple illumination sources, including halogen, LED, and mercury vapor lamps, depending on the application. LED illumination, in particular, provides highly stable light output and is energy-efficient, which is crucial when performing long-duration imaging or fluorescence work. The microscope also includes a light condenser system, with options for both Abbe condensers and aplanatic condensers, depending on the desired contrast and resolution.

The fluorescence module features motorized filters, enabling users to switch between different fluorochromes with ease and perform multi-channel fluorescence imaging. The filter cube system is highly customizable, allowing researchers to add or replace optical filters based on their specific requirements.

8) Modular Design and Expandability

One of the defining features of the Axioplan 2 is its modular design, which enables users to configure the system to suit a wide array of imaging needs. This modularity is a key reason why the Axioplan 2 is well-suited for both routine laboratory work and cutting-edge scientific research.

A) Motorized Focus and Stage Movement

The motorized focus system allows for precise control over the focal plane, which is essential when working with thick samples or when performing 3D imaging. The system is also integrated with focus tracking technology, which helps maintain focus even when the objective lens is switched. Additionally, the motorized stage provides smooth, precise movement, which can be controlled via software or a joystick. This allows users to scan larger samples efficiently while maintaining high levels of accuracy.

B) Stage and Sample Handling

The Axioplan 2's mechanical stage is engineered to handle specimens with precision. Equipped with X-Y translation controls, it ensures that the sample can be accurately moved along the horizontal plane without distortion. The stage is designed for high load capacity, meaning it can

accommodate both standard slides as well as thicker or heavier samples, such as slides with large tissue sections or multi-well plates.

The translation stage has integrated focus drive components, which allow for uniform vertical motion during specimen observation. The system can also be adapted for Z-axis motorized control for focusing on thick or multi-layered samples.

9) Fluorescence and Advanced Imaging Techniques

The Axioplan 2 Imaging model is specifically designed for advanced fluorescence and confocal imaging, making it a popular choice in cell biology, molecular imaging, and medical diagnostics.

A) Fluorescence System

The fluorescence system in the Axioplan 2 is fully integrated, providing high throughput with motorized filter wheels for rapid switching between different fluorochromes. The filter cubes are designed for specific fluorophore excitation and emission spectra, ensuring that the system produces clear and bright images without spectral overlap. This is particularly important in complex imaging tasks, such as multi-label fluorescence microscopy, where precise spectral separation is critical.

Additionally, the fluorescence illumination is optimized with high-quality optics that reduce optical aberrations and improve light transmission. The system can also be configured with dichroic mirrors that optimize the reflection and transmission of light across different wavelengths.

B) Differential Interference Contrast (DIC) and Phase Contrast

The Axioplan 2 is equipped with advanced DIC and phase contrast modules, enabling the visualization of unstained, transparent specimens with enhanced contrast. The DIC prism system utilizes interference effects to generate high-contrast images, allowing the researcher to examine detailed structures in live cells or tissues. The phase contrast feature, on the other hand, is ideal for observing biological specimens that lack significant natural coloration, such as live cells.

These imaging modes are particularly useful in studying biological samples in their natural state without the need for staining, making the Axioplan 2 an indispensable tool in biological research.



Diffuser Filter Lamp source collimating lens

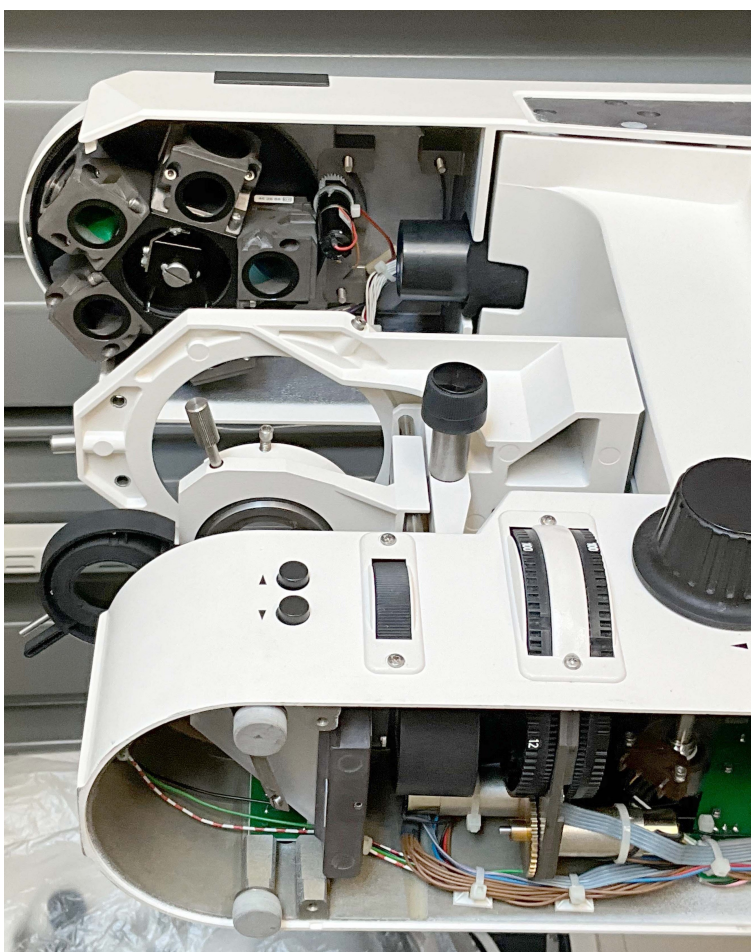

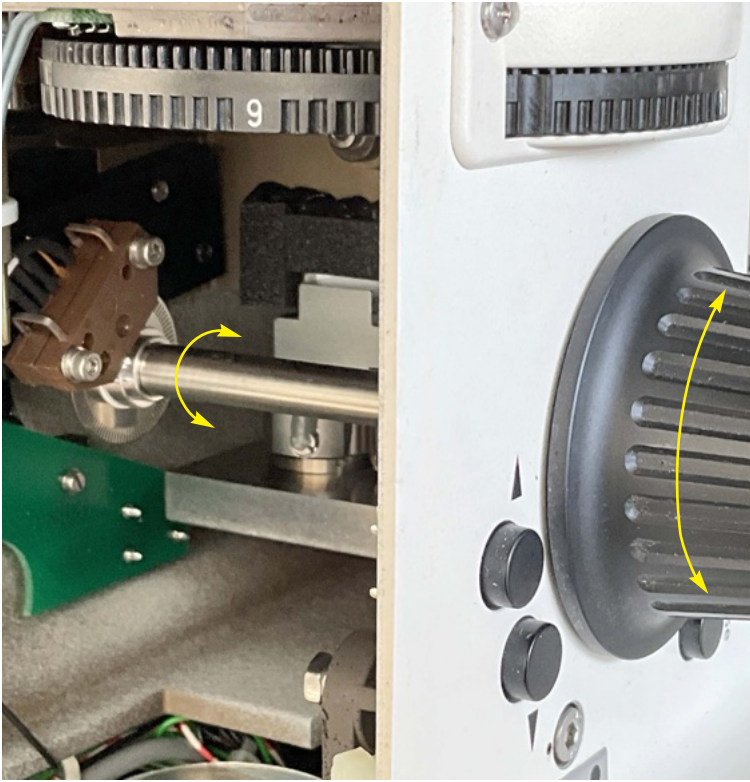

Two views of the focusing mechanism: The optical encoder sends pulses to a servo circuitry to control the largest motor in the instrument. The entire weight of the sample stage is on this motor.

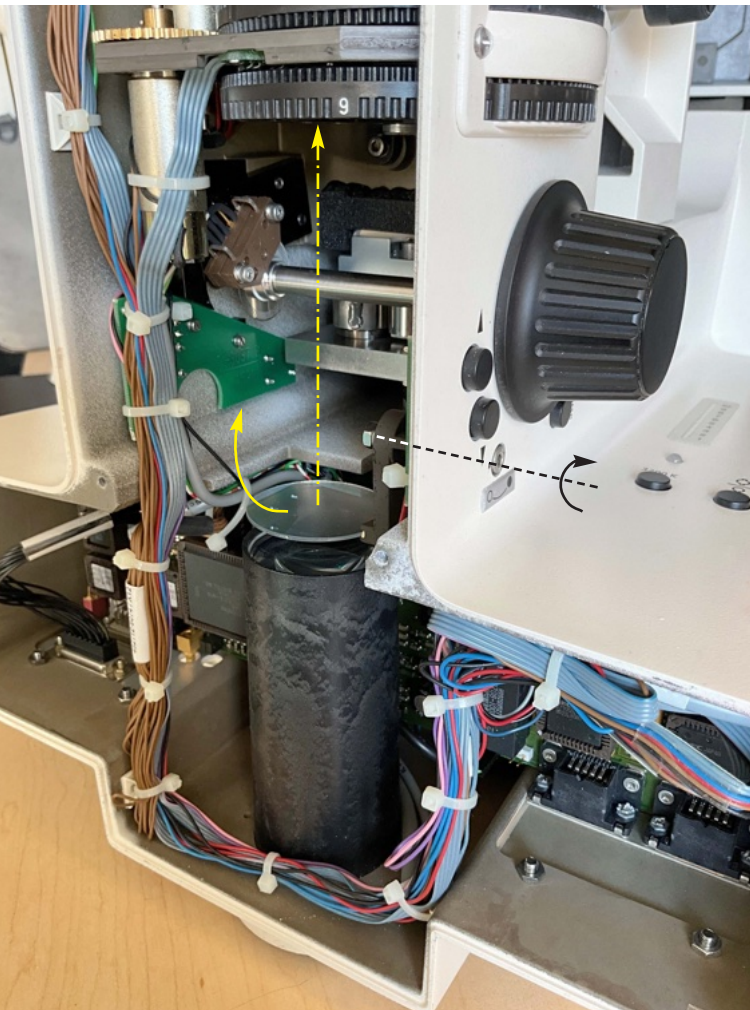

Simplistic design of diffused filter insertion through the optical path

10) Ergonomics and User Interface

The Axioplan 2 was engineered with an emphasis on user comfort and ease of use. The ergonomic design of the microscope allows for extended periods of observation with minimal strain, which is particularly beneficial in high-throughput environments or during long imaging sessions.

A) Focus Mechanism and Knobs

The focus knobs are designed for smooth, tactile operation, providing precise control over focusing. The coarse and fine focus controls are conveniently placed on both sides of the microscope, enabling both right- and left-handed users to operate the system comfortably. The mechanical stage and focus mechanisms are calibrated to allow micro-adjustments that are critical for imaging at high magnifications.

B) User Interface and Software Integration

The Axioplan 2 can be controlled via the Zeiss software suite, such as ZEN or AxioVision, which provides advanced image acquisition, processing, and analysis tools. The software allows for automatic focus, multi-dimensional imaging, and live cell tracking. The interface is intuitive, with touch-screen compatibility and a layout that minimizes the need for complex menu navigation, making the microscope accessible even to novice users.

11) System Stability and Durability

The overall construction of the Axioplan 2 is designed for long-term durability and stability. The solid metal frame ensures minimal vibration during use, which is essential for high-magnification imaging. The closed-loop focusing mechanism and optical system are designed to provide consistent performance even after prolonged use.

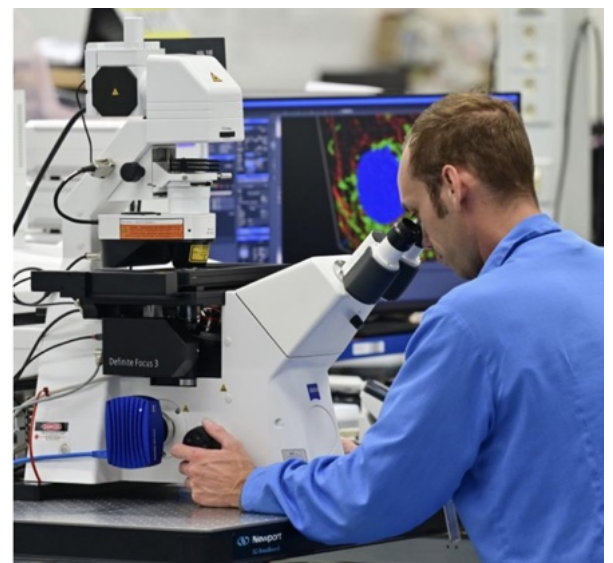

Factory testing of Zeiss Axiovert

Additionally, the temperature stability and vibration resistance of the system contribute to the accuracy and consistency of results, especially in sensitive applications like live-cell imaging and quantitative analysis.

Development Cost of Axioplan Microscope line

Determining the exact cost that Zeiss incurred to develop the Axioplan microscope design is difficult, as such financial details are typically not disclosed by companies. However, we can infer some insights into the likely development costs based on the general scope of such a project, the engineering expertise required, and the nature of the Zeiss company at the time.

1. R\&D Investment in Optical Technology:

Zeiss has long been a leader in optics and precision engineering. Developing the Axioplan microscope required significant investment in optical research, material science, and lens design. The development of apochromatic lenses (a hallmark of the Axioplan's performance) and planar optics would have necessitated extensive testing, prototyping, and refinement of optical elements to

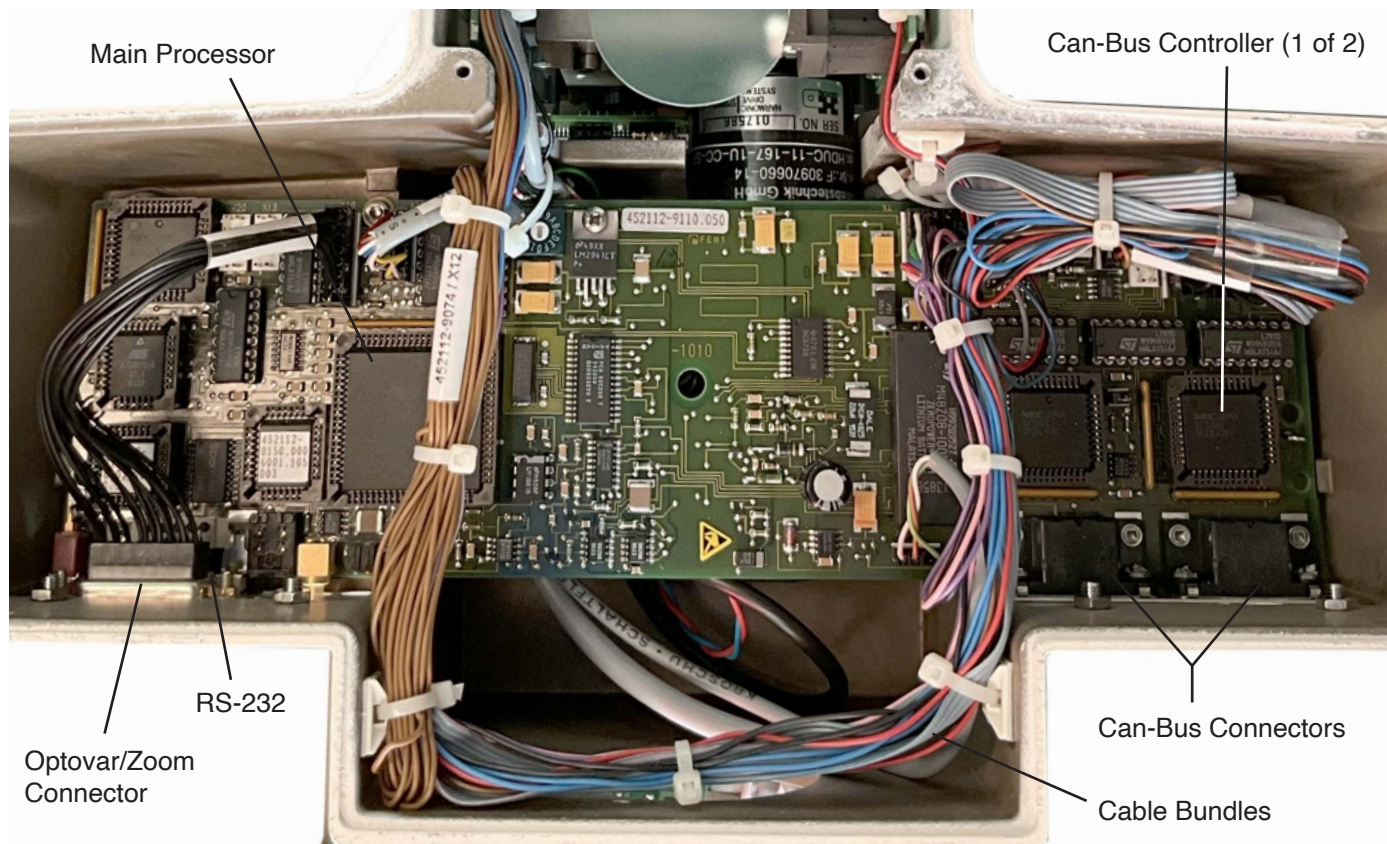

There are two boards controlling the microscope, powered by the power supply unit (above, right) supplying the power to electronics boards, and the two halogen lamps. The main board (above) sits at the bottom of microscope. This is where the main processor resides. The cable bundles connect the filter wheel motors/encoders, focus motor, control switches, display LEDs, focus wheel encoder, filter cube position encoder, turret position encoder to electronics boards.

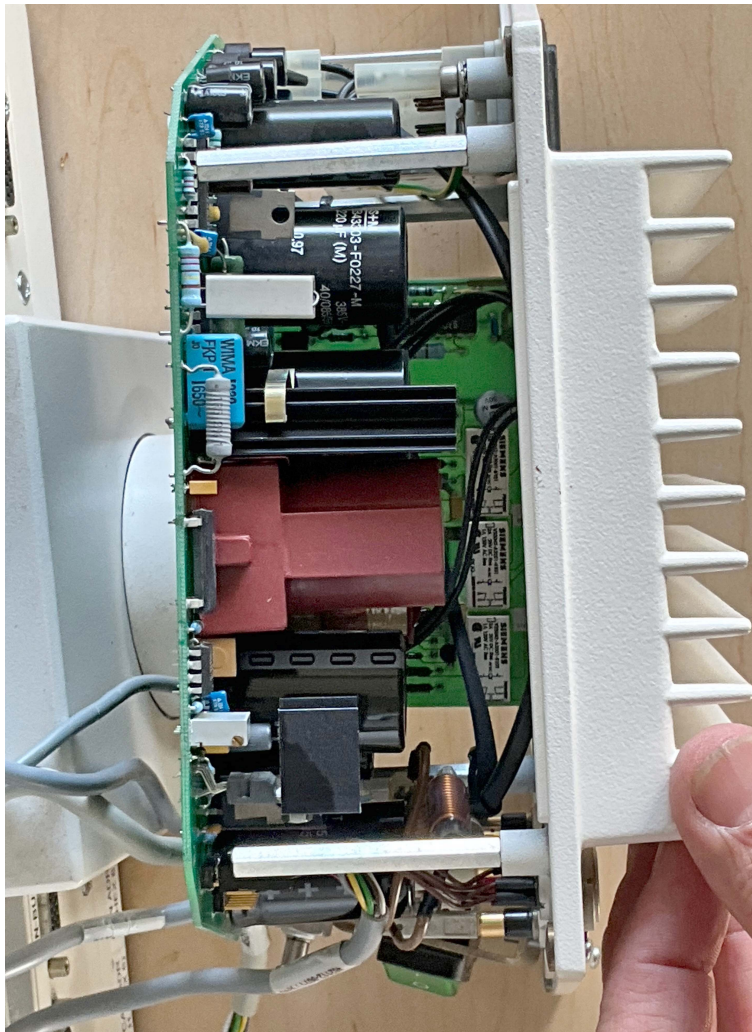

ensure high-quality image resolution and minimal chromatic and spherical aberrations.

2. Modular and Customizable Design:

The modular design of the Axioplan allowed for the customization of various components like objectives, condensers, and illumination systems. This required considerable engineering expertise to design a system that could support different configurations while maintaining precision, mechanical stability, and ease of use. The interchangeable components required careful integration and optimization to ensure system compatibility, adding to the development cost.

3. Motorization and Automation:

The introduction of motorized stages and focus mechanisms in the Axioplan 2 model (released in the early 2000s) would have represented a significant investment in electronic controls and automation technology. Developing software to automate image acquisition, focus control, and filter selection likely required collaboration between engineers and software developers to ensure seamless integration between hardware and software.

4. Quality Control and Precision Manufacturing:

Zeiss is known for its high-precision manufacturing processes, and the Axioplan would have undergone rigorous testing and quality control. This would have involved developing specialized manufacturing tools for microscopic optical components and ensuring that the mechanical and optical elements met Zeiss's high standards. The cost of production would have been influenced by the need for tightly controlled tolerances in both the optics and the microscope's mechanical systems.

5. Research into Fluorescence and Imaging Capabilities:

The Axioplan microscopes were designed with fluorescence capabilities in mind, which was a growing area of research during the late 1980s and 1990s. Developing and integrating fluorescence modules, including motorized filter wheels and advanced light sources, required significant investment in optical design and illumination technologies.

6. Marketing and Positioning:

Zeiss would also have needed to invest in marketing efforts to establish the Axioplan as a leading microscope in the academic, medical, and industrial research markets. This would have in-

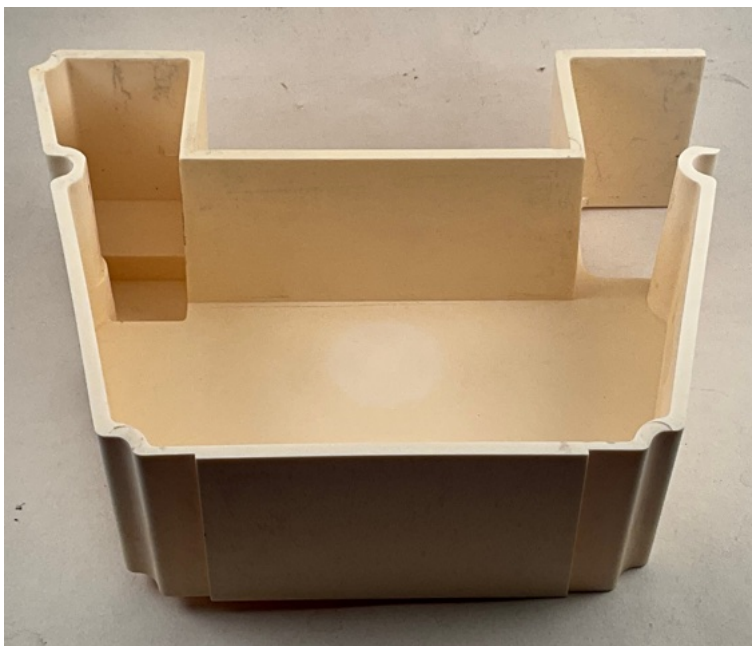

Plastic cover of Zeiss Axioplan 2 reveals Zeiss's attempt to make the microscope modular. The cover is made of thick plastic to enclose all the cabling as part of the pack plane of easier assembly.

cluded promotional campaigns, scientific partnerships, and support for academic research to demonstrate the microscope's capabilities and generate demand.

Rough Estimation Based on Industry Standards:

Given the advanced technologies involved and the level of investment required, we can hypothesize a rough development cost for the Axioplan series based on industry standards for high-end scientific equipment:

Optical research and design: Developing a high-end optical system for a microscope can easily cost several million dollars, especially when advanced features like apochromatic objectives and fluorescence capabilities are integrated. Companies like Zeiss typically invest heavily in optical research, especially when pushing the boundaries of microscopy.

Mechanical engineering and prototyping: The modular, customizable design of the Axioplan, coupled with motorized systems and interchangeable parts, likely required millions in engineering and prototyping efforts.

Software development: Developing integrated software for controlling motorized components, automated imaging, and analysis systems would have required a specialized software engineering team. For a complex microscope system like the Axioplan, the cost of software development could range from hundreds of thousands to a few million dollars.

Manufacturing and quality control: Manufacturing precision components and maintaining quality control on the microscope would involve high overhead costs, including the use of clean room facilities for assembling the optical elements and robotic precision systems for the mechanical components.

Total Estimated R&D Investment: A ballpark estimate for the total cost of developing a sophisticated system like the Zeiss Axioplan could range from \$5 million to \$20 million or more, depending on the level of integration, innovation, and time spent on development.

Further estimates:

Short answer: There's no public, itemized figure for how much ZEISS spent specifically to develop the Axioplan / Axioplan 2 line. I searched ZEISS materials, product brochures and annual reports and could not find any published R&D cost tied to that product line.

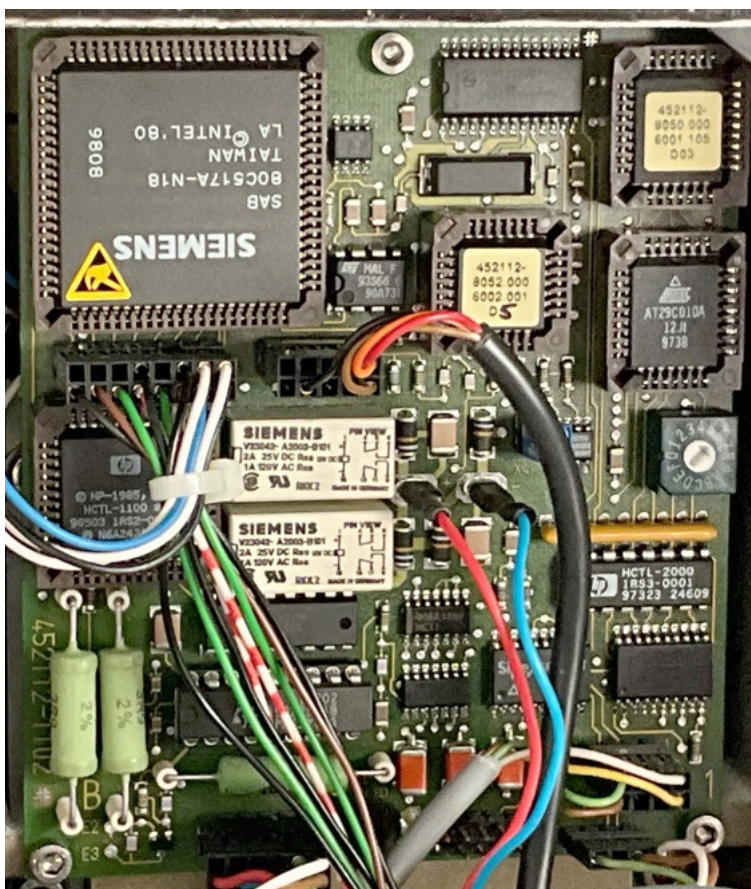
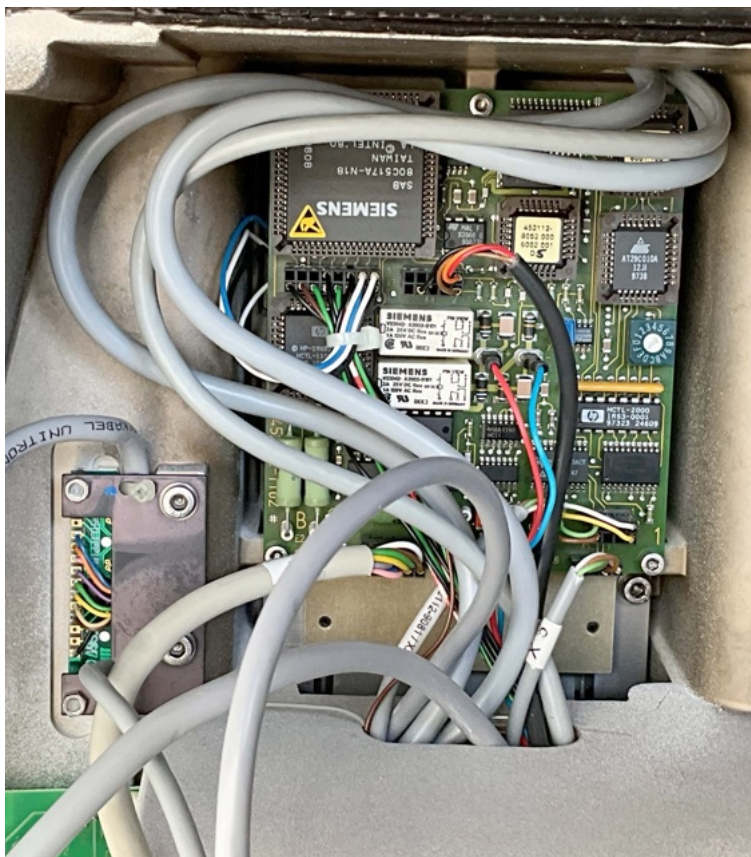

Motor Driver Board 2 resides on the back of the microscope. It contains Siemens Micro-Controller, to control the large focus motor, filter wheels, and receives signals from focus, and position encoders, end switches, etc.

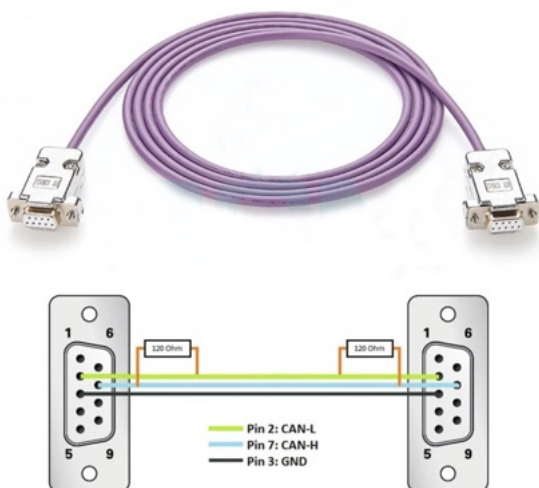
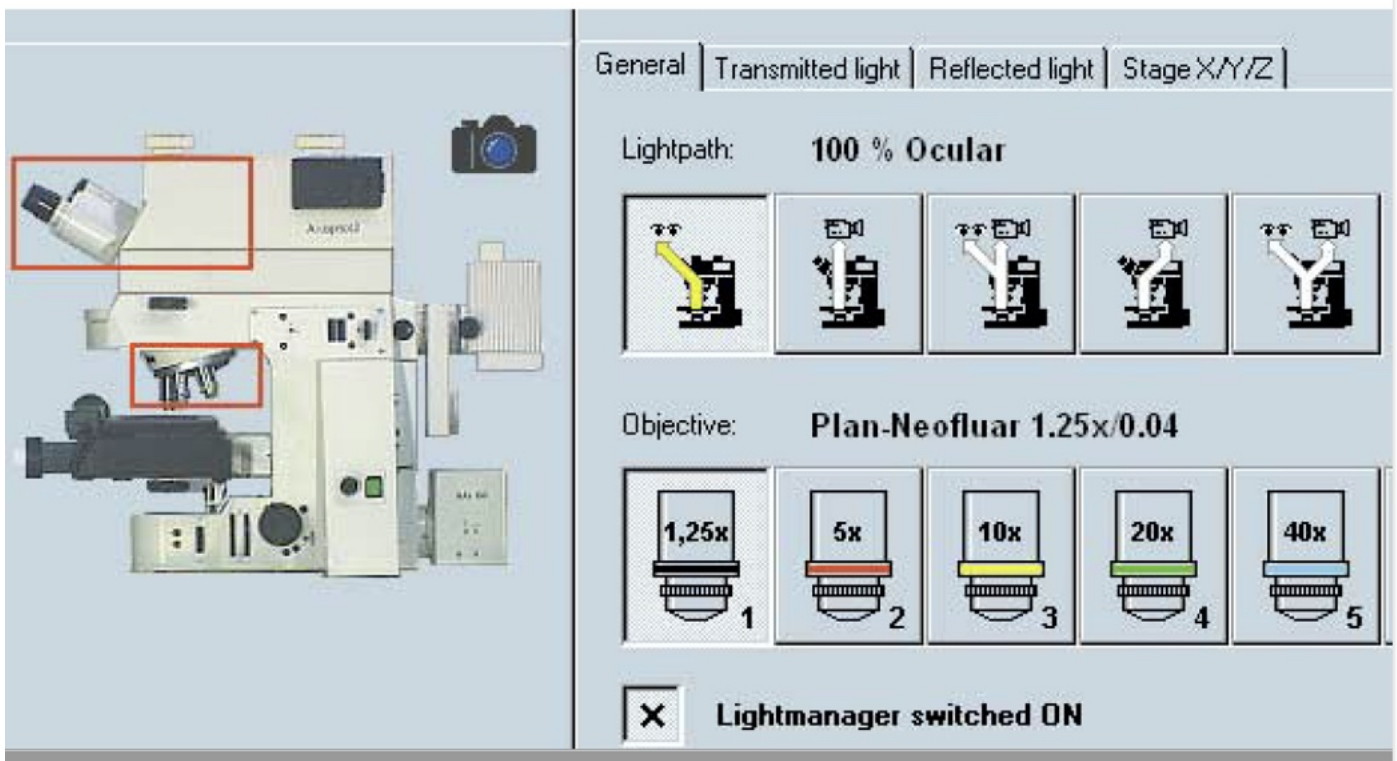
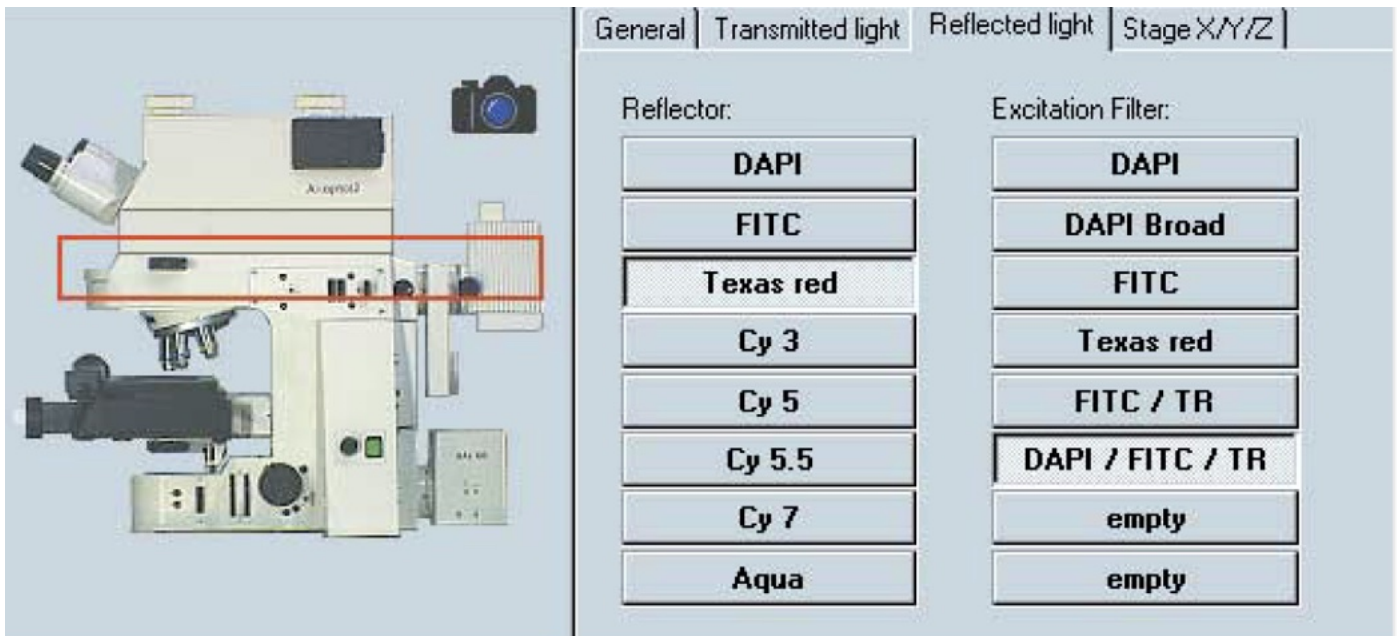

The serial control interface cable (left) links the motorized/encoder components of Axioplan 2 microscope with Zeiss's dedicated software (next page).

The graphical user interface enables the user to program the settings between the objective, transmission filters, and filter cubes to correlate with the nosepiece to arrange best setup for each magnification, i.e., for uniform illumination when switching between objectives, or layering the imaged into several images using the motorized focus, and image capture software.

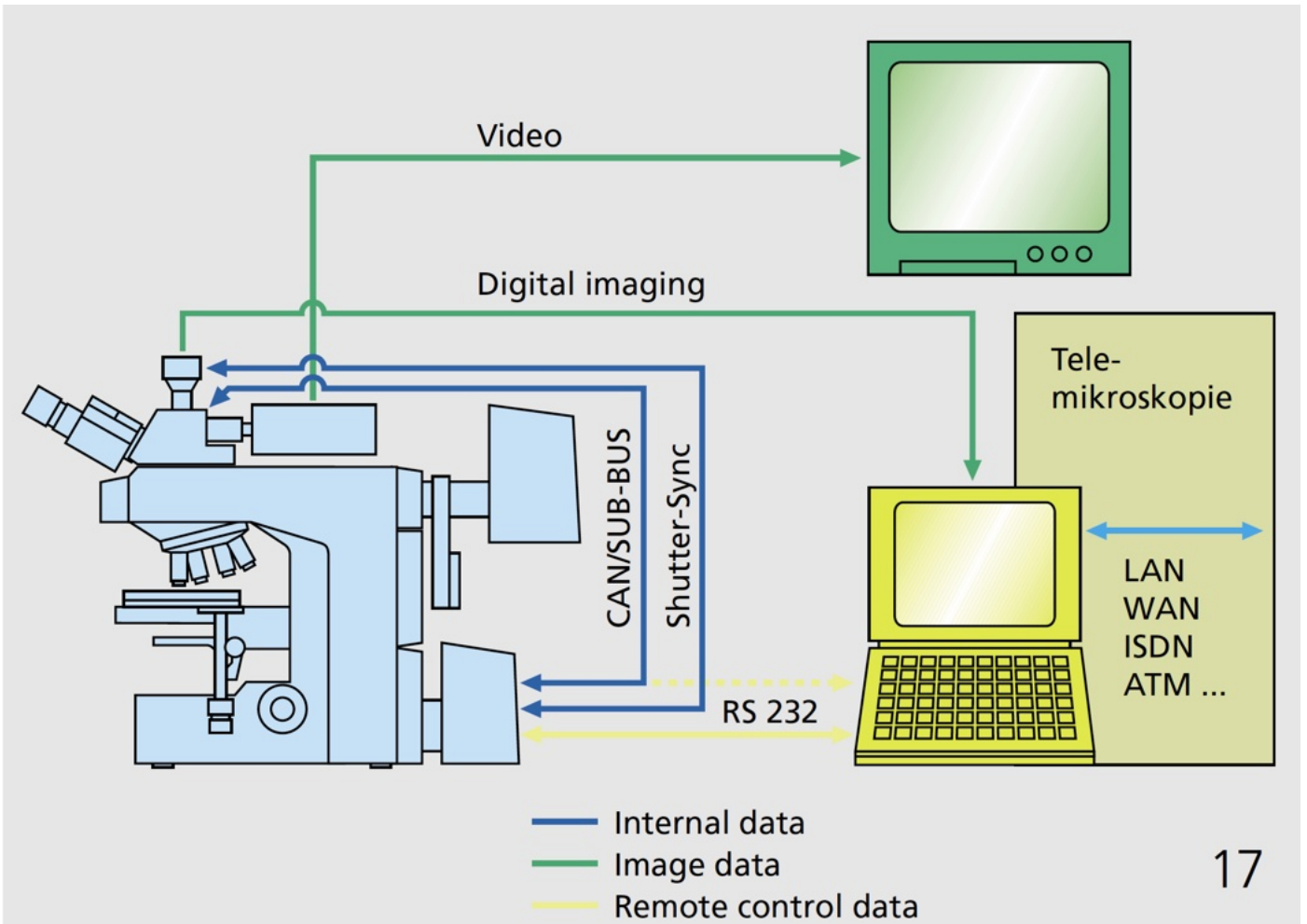

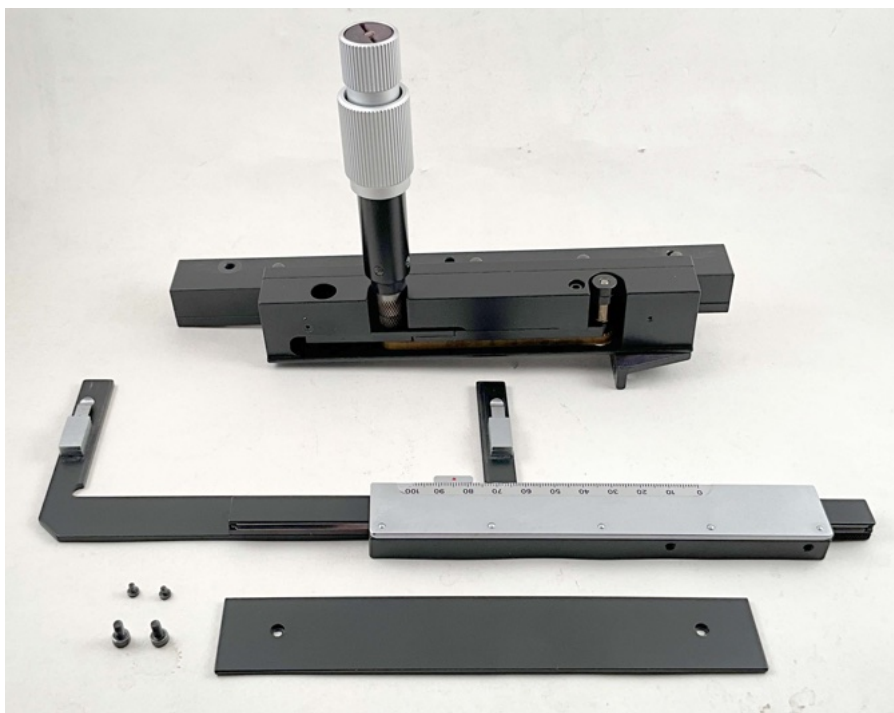
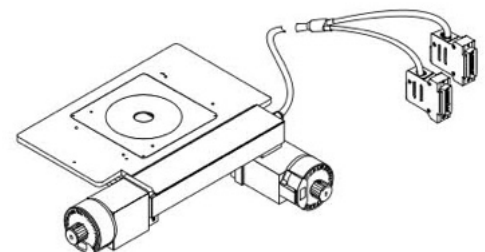
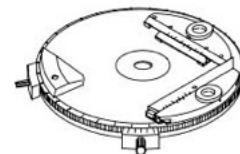
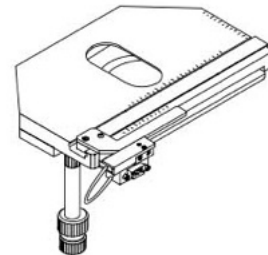
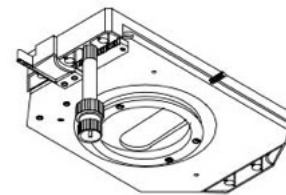
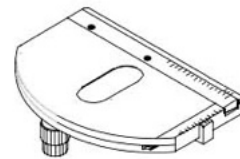
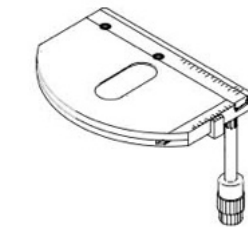
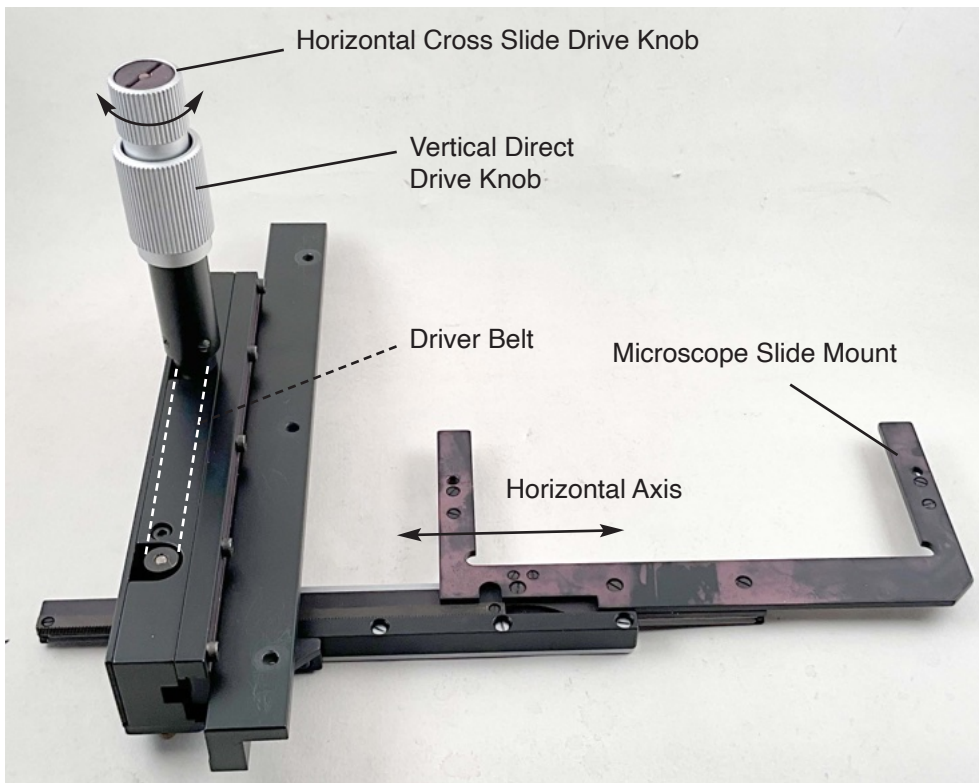

Large companies (ZEISS included) report R&D at the group or division level, not by single product lines. ZEISS's published R&D spending is therefore available only as totals or division-level numbers. The Axioplan/Axioplan-2 is a now-discontinued line (end-of-service dates on ZEISS pages), which makes finding any one-time historic program cost even less likely in public documents.

A reasonable, transparent estimate, below I give a back-of-the-envelope estimate and the assumptions behind it so you can judge whether it's useful.

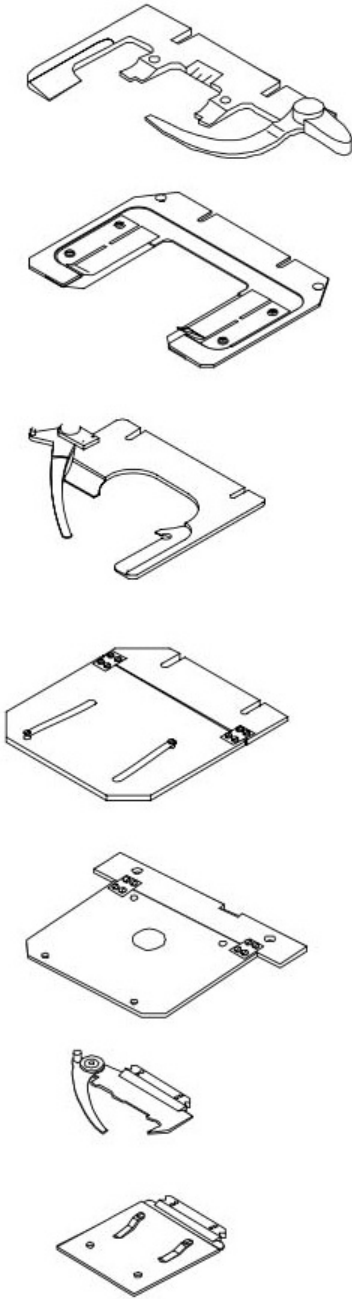

Opposite page, right: Various X-Y stages that would fit on Zeiss focusing stage. Above: Variety of slide holders designed to fit on the Zeiss stages.

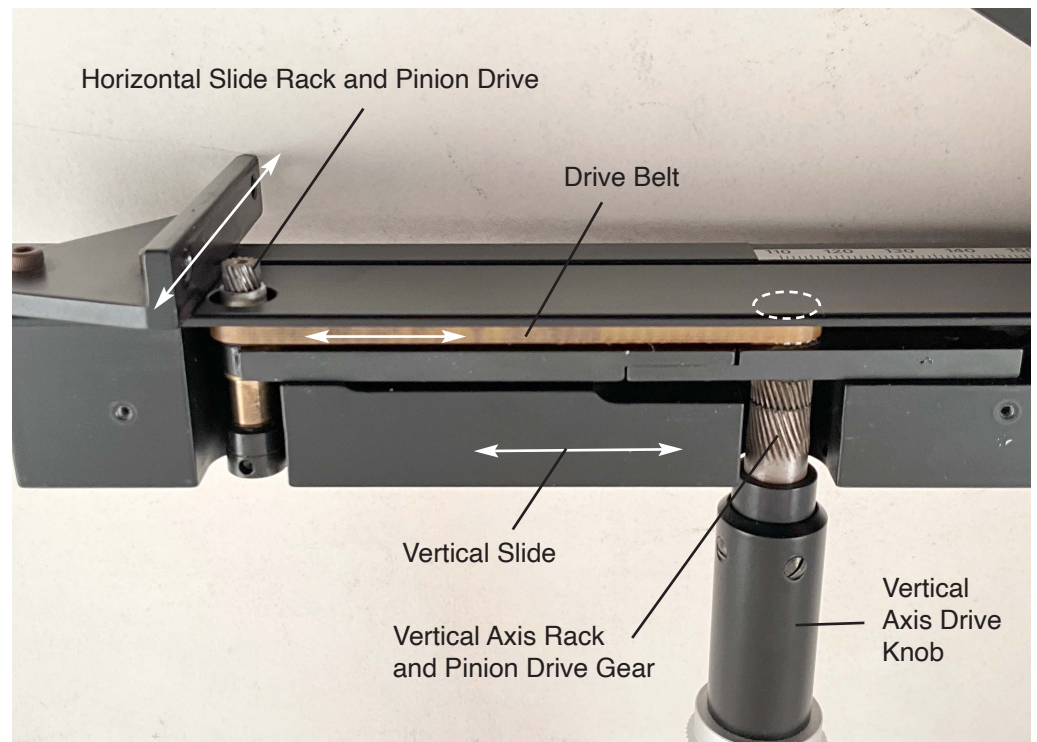
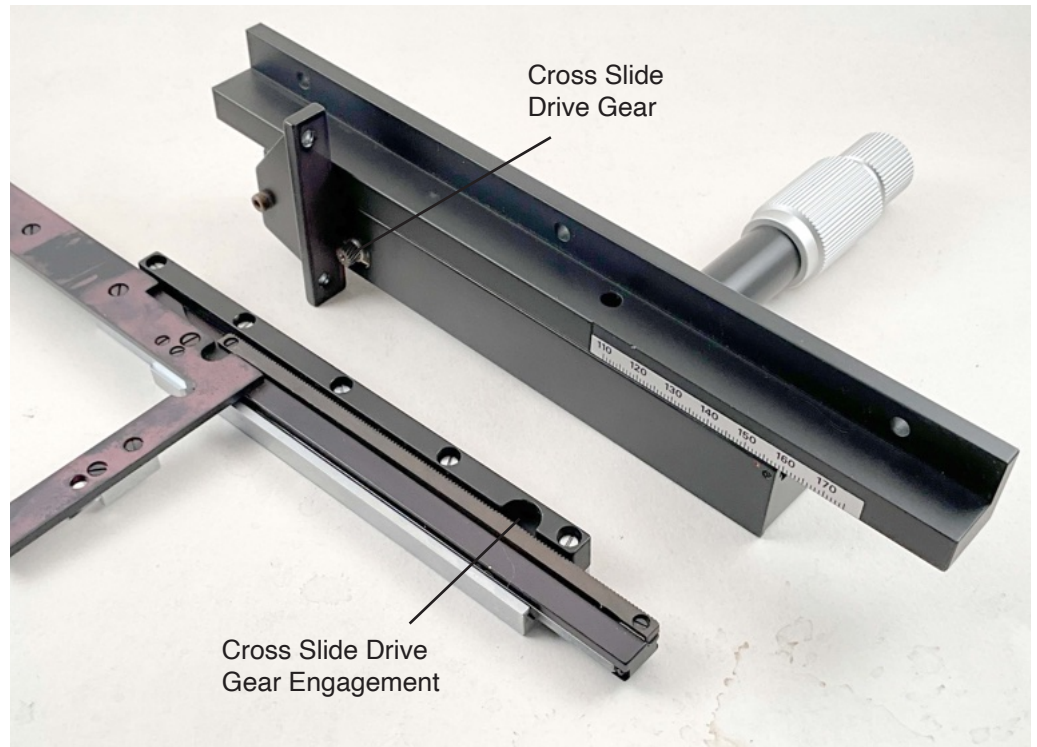

1. Relevant public numbers

ZEISS Group R&D is in the hundreds of millions per year (example: ~€284M reported for a reporting year cited in articles/annuals). ZEISS also reports multi-year totals (over €1.5B in recent aggregated R&D).

2. Typical allocation logic

Product development for a single sophisticated optical instrument at a large diversified company is normally a small fraction of total R&D. That fraction depends on how many concurrent projects the company had, whether development included new manufacturing lines, software, or platform costs reused across products, and the multi-year span of development.

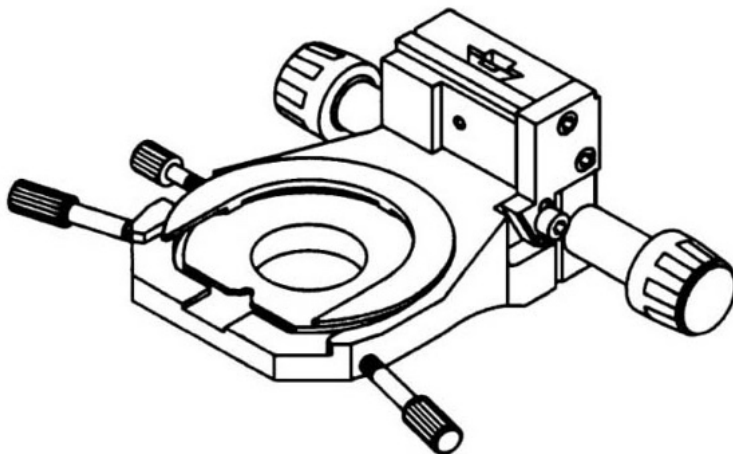

3. Scenario estimates

Low-end (small project / incremental update): €0.5M – €2M.

Assumes Axioplan was largely an evolution of existing optical platforms and used existing supply chain and software.

Mid-range (new hardware + optics + electronics + software, 2–3 years): €2M – €10M.

Plausible if a modest cross-functional team (optics, mechanics, electronics, firmware, validation) worked 1–3 years and some costs are capitalized.

High-end (major new platform, full system integration, multi-year, multiple prototypes): €10M – €50M+.

Possible only if the program created lots of new tooling, new production lines, clinical/regulated validation, and significant software/automation investment.

How these figures were reached:

If a single product team of 10–30 engineers/technicians runs for 2 years at fully-loaded cost €100–€150k per person-year → personnel cost ≈ €2–€9M. Add prototyping, optics tooling, external contracts, certification, and overhead → pushes to mid/high range.

[1] :https://neurophysics.ucsd.edu/Manuals/Zeiss/AxioplanBrochure.pdf?utm_source=chatgpt.com "Axioplan 2 imaging The Universal Microscope System"

[2]:https://www.zeiss.com/corporate/en/about-zeiss/present/facts-figures.html?utm_source=chatgpt.com "Facts & Figures | ZEISS Group"

[3]:https://www.zeiss.com/microscopy/us/service-support/support/discontinued-products.html?utm_source=chatgpt.com "Discontinued ZEISS Microscopy Products"

[4]: https://www.labmanager.com/carl-zeiss-expects-recovery-in-2010-19943?utm_source=chatgpt.com "Carl Zeiss Expects Recovery in 2010"



Trinocular Observation Head

The observation head in Axioplan 2 microscope has slim/elongated body design to match the contours of the main microscope diecast body. Through the years, Zeiss has developed several trinocular heads for Axioplan.

For ergonomic use, instead of a tiltable viewing head, Zeiss has an alternative height adjustable observation head. It takes advantage of the infinity (parallel) light path to elevate the viewing point without losing focus.

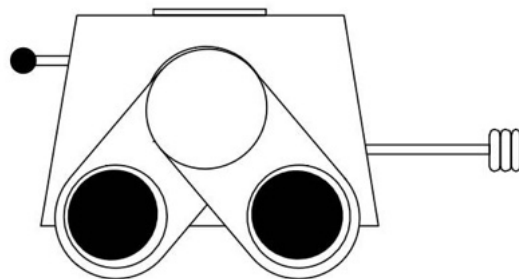
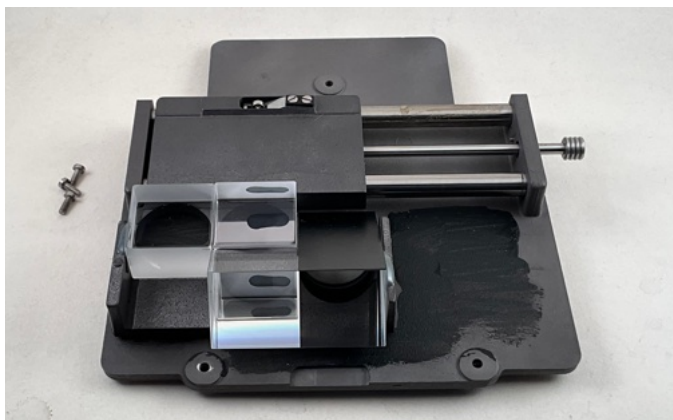
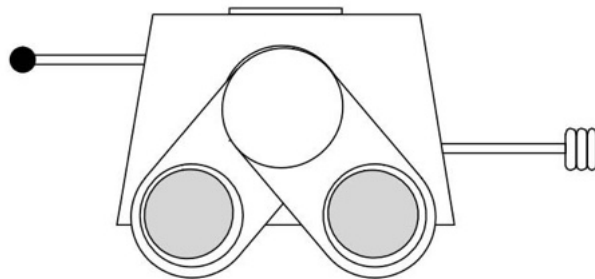
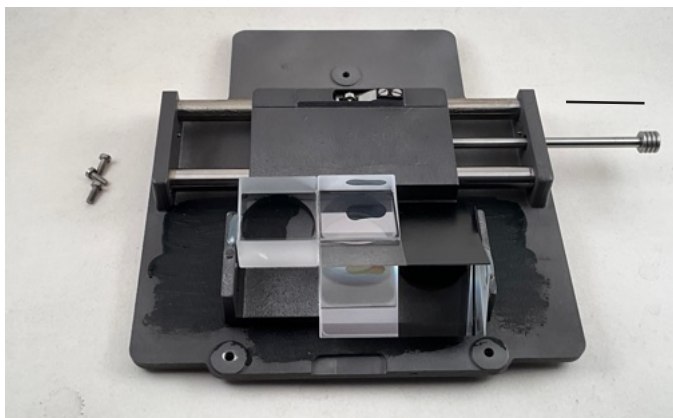
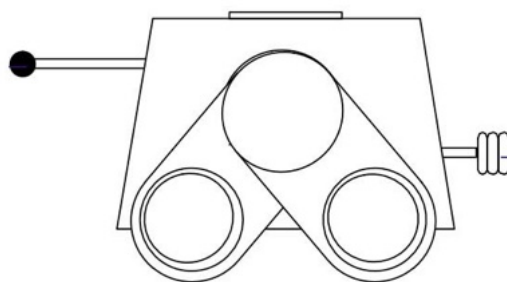
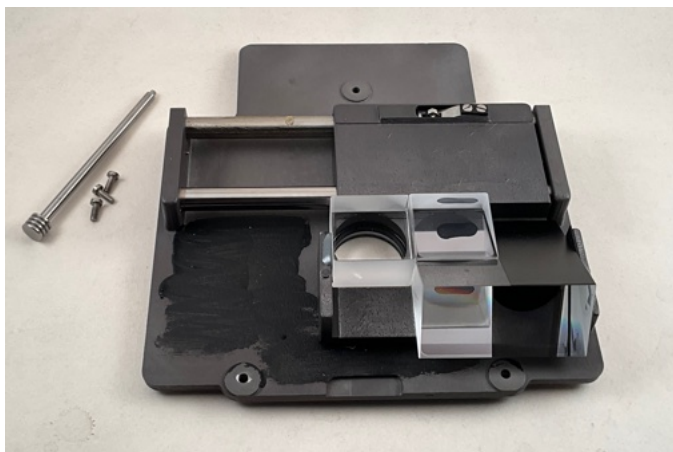

Three modes of viewing are accomplished with internal prism work. 100% viewing (top), to partial illumination viewing (middle), and total transmission of image to the camera (bottom). There is also a shutter slider for complete blockage.

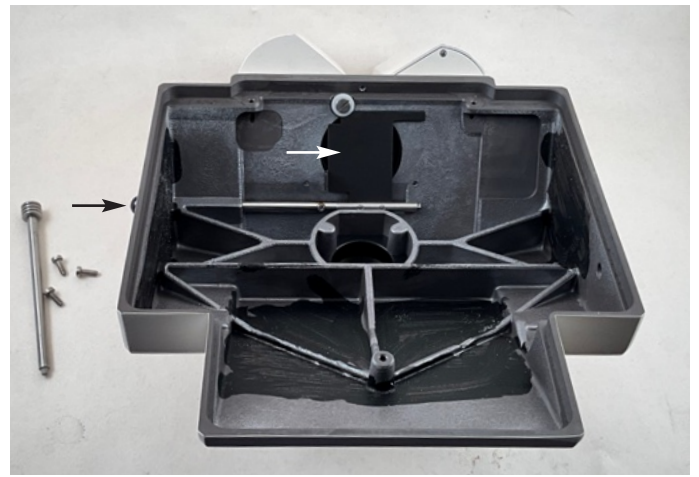
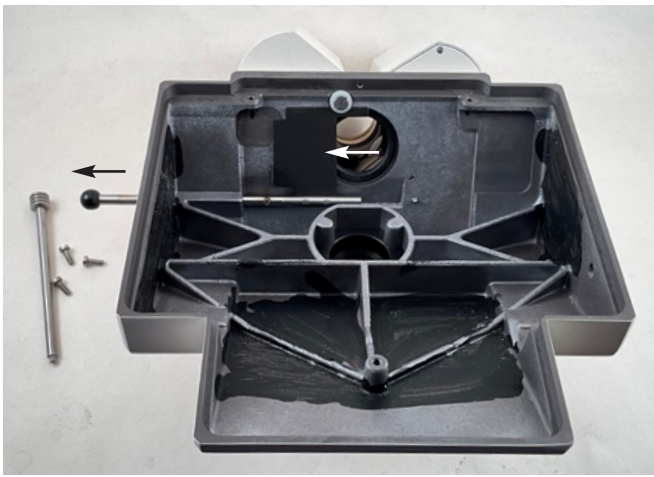

Rear view of trinocular viewfinder top cover reveals the mechanical shutter controlled by control slider (above). Zeiss utilizes sticky black paint to collect internal dust inside Axioplan housing and all its accessories.

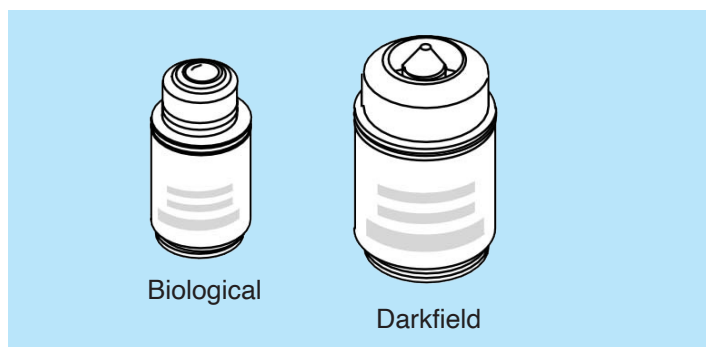
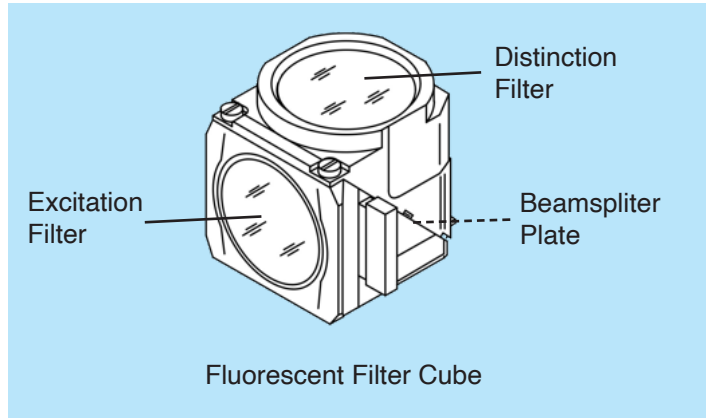
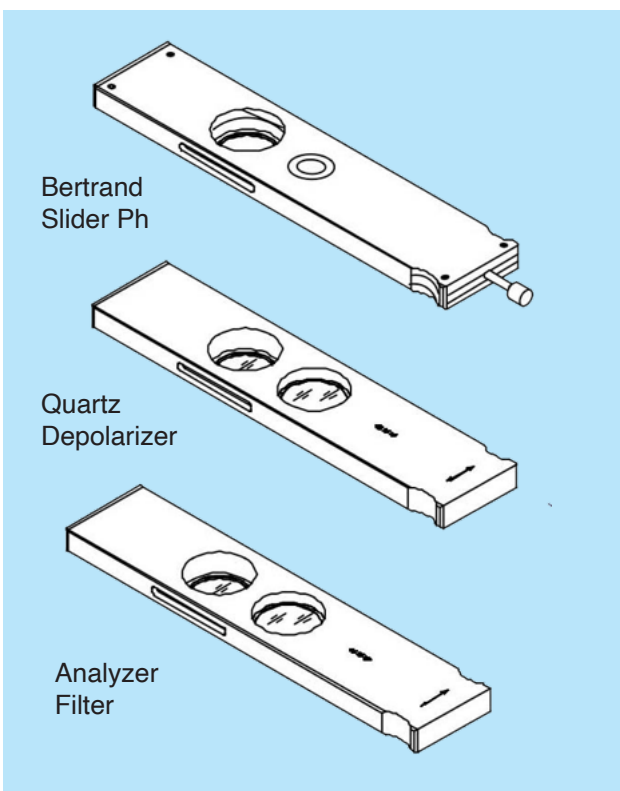
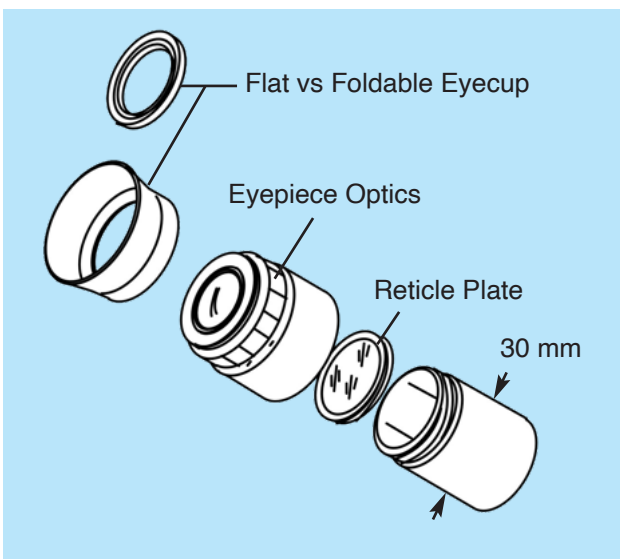

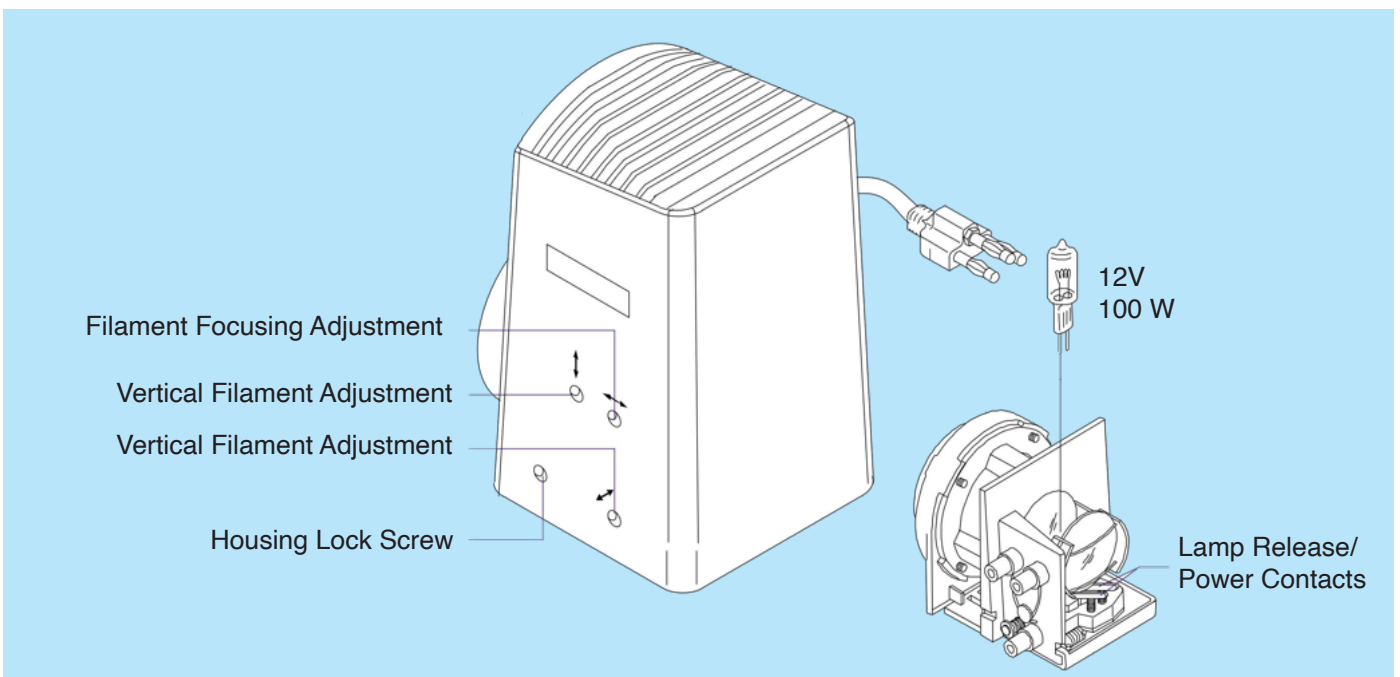
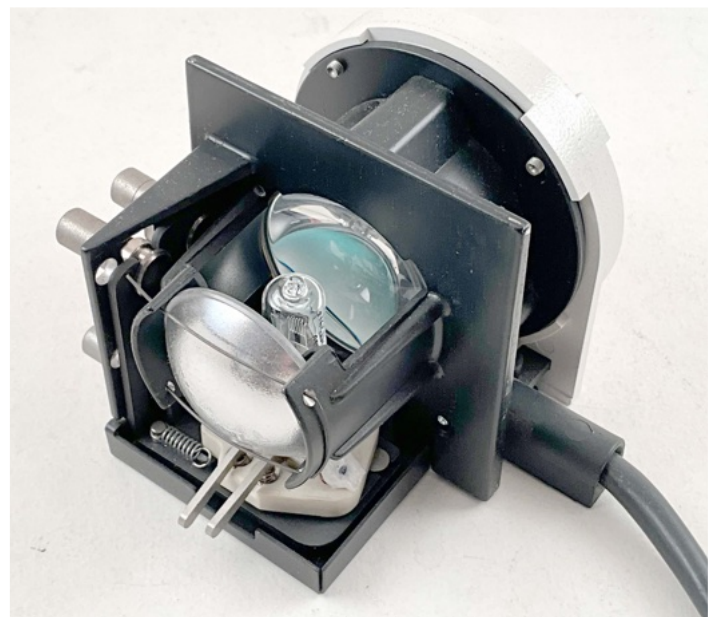
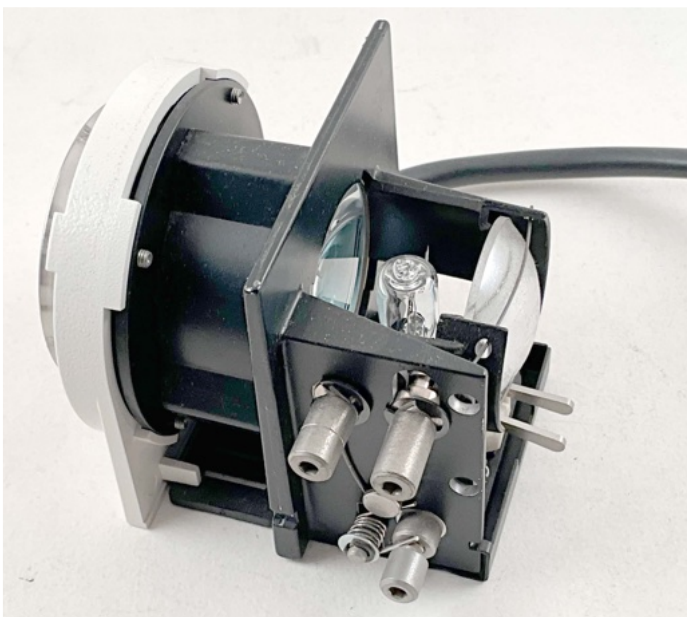
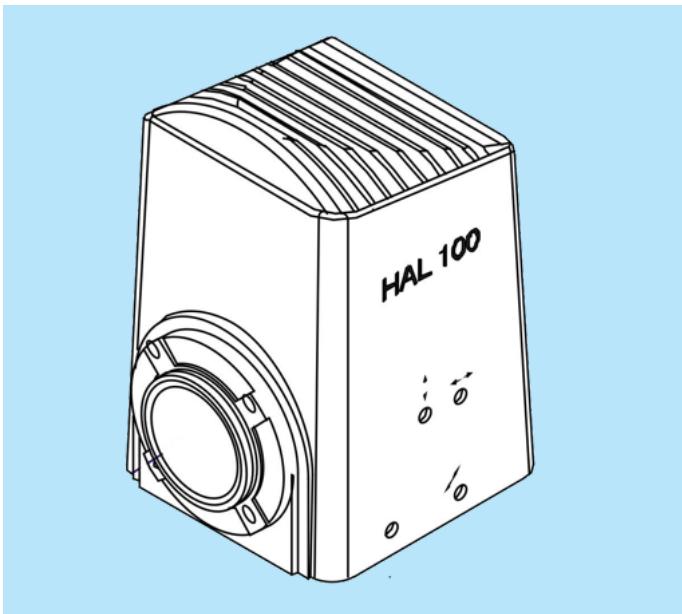

Axiovert 100 Design

Axiovert (first 1982; Axiovert 100 in 1986). The Axiovert was Zeiss's response to Nikon's Diaphot (1979)—a compact, modular inverted microscope for live-cell work.

Design direction: maximize optical performance while allowing large stage clearance for culture vessels. Optical layout and mechanical design were handled by the same ICS engineering group that did Axioplan — the Axioline program was shared between upright and inverted versions.

Key innovations:

ICS infinity system (same tube lens, objective standard).

New ergonomic inverted stand. Modular illumination and fluorescence turrets.

Same industrial design language as Axioplan.

For industrial / Aesthetic Design Zeiss collaborated with frogdesign (Hartmut Esslinger) — the same industrial design consultancy that worked for Apple and Wega/Sony—in the early 1980s to create the “Axioline” visual identity.

Characterized by clean, functional forms, integrated modules, soft gray/white enamel, and green Zeiss accents. This aesthetic debuted with Axioplan (1986) and Axiovert 100 and persisted through the Axioskop and Axio Imager lines.

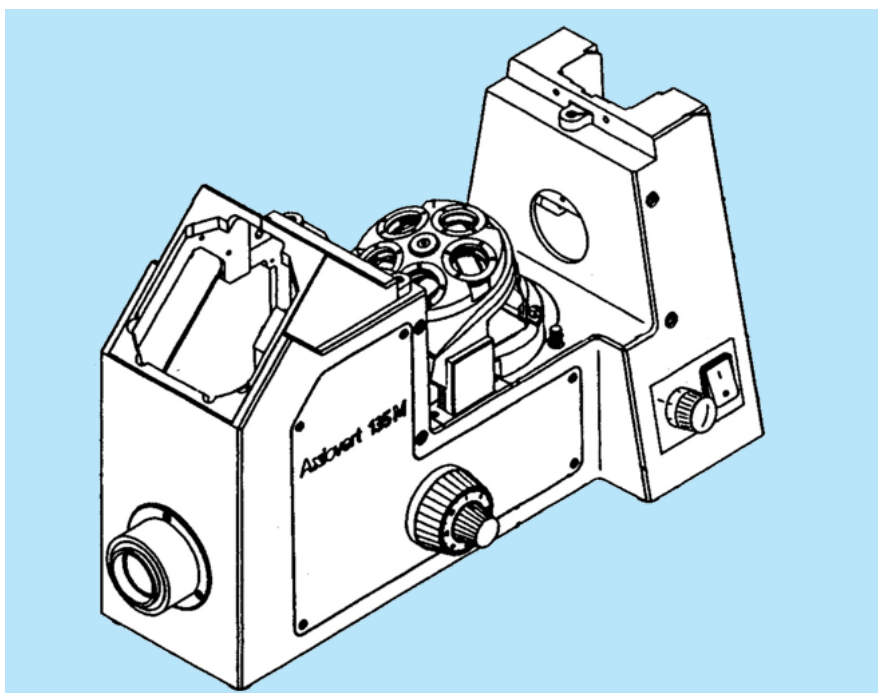
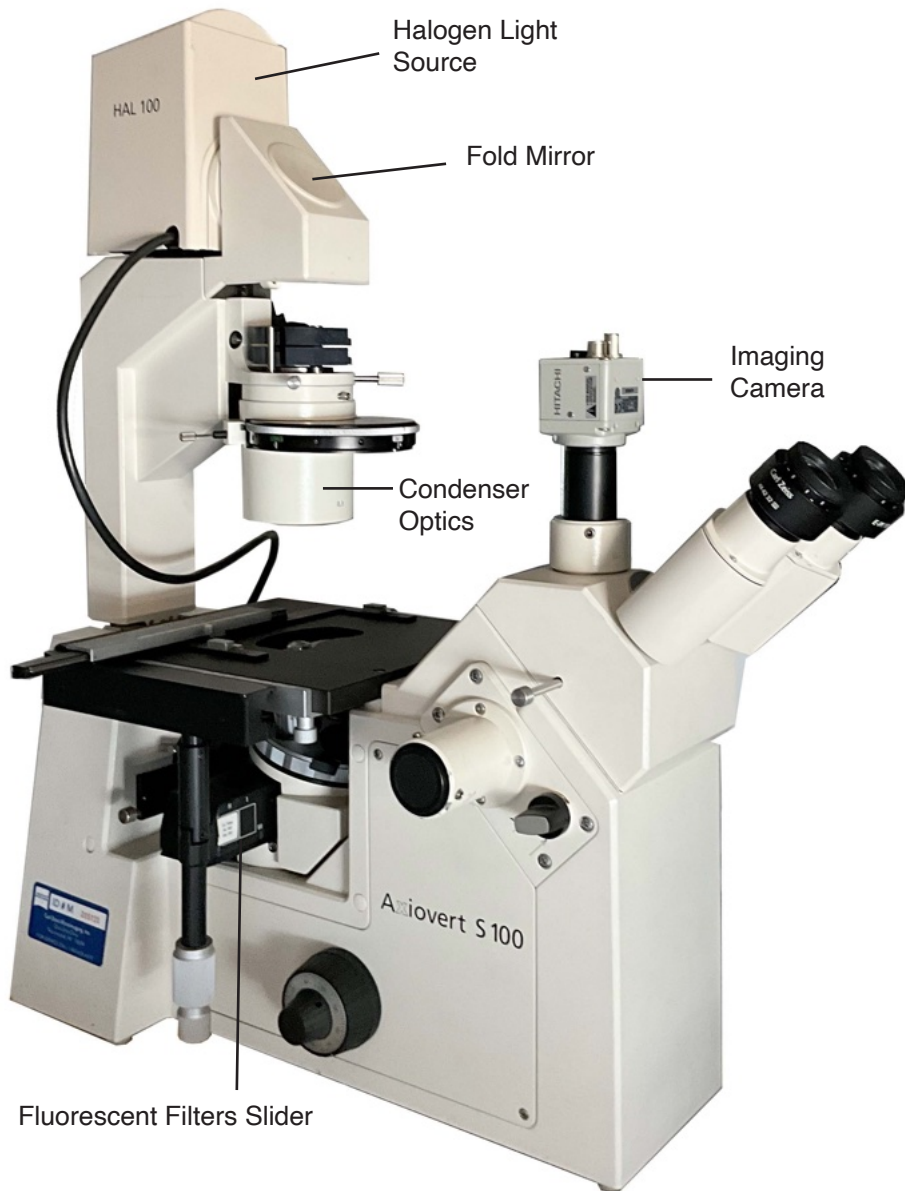

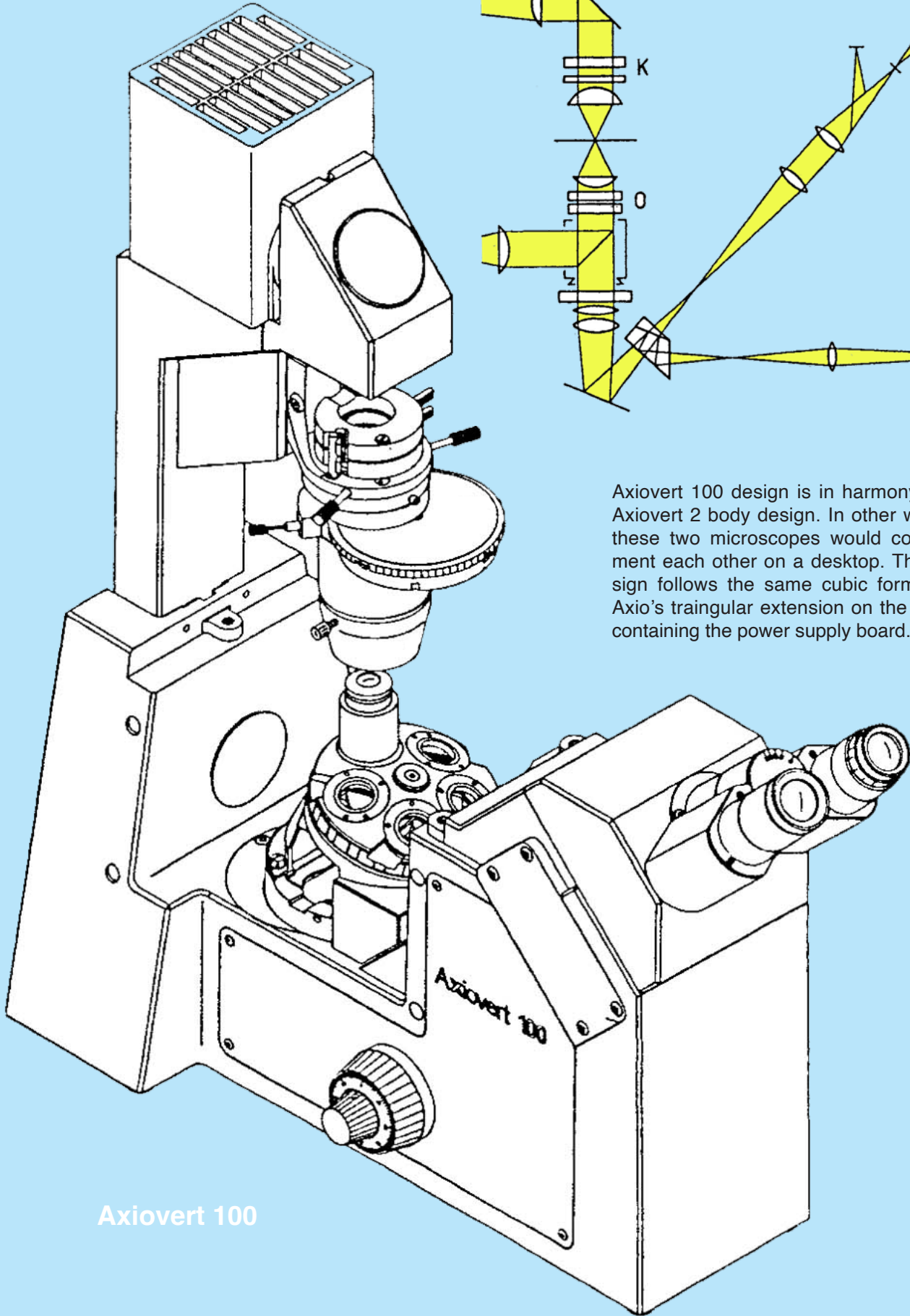

Axiovert 100

Axiovert 100 design is in harmony with Axiovert 2 body design. In other words, these two microscopes would complement each other on a desktop. The design follows the same cubic form with Axio's traingular extension on the back, containing the power supply board.

Axiovert 100 with its sample platform removed. In contrast with Axioplan, this arrangement offers more flexible space to expand microscope's capabilities. In Axiovert, thick washer spacers may be added beneath the sample platform to adjust to the working distance of the objectives.

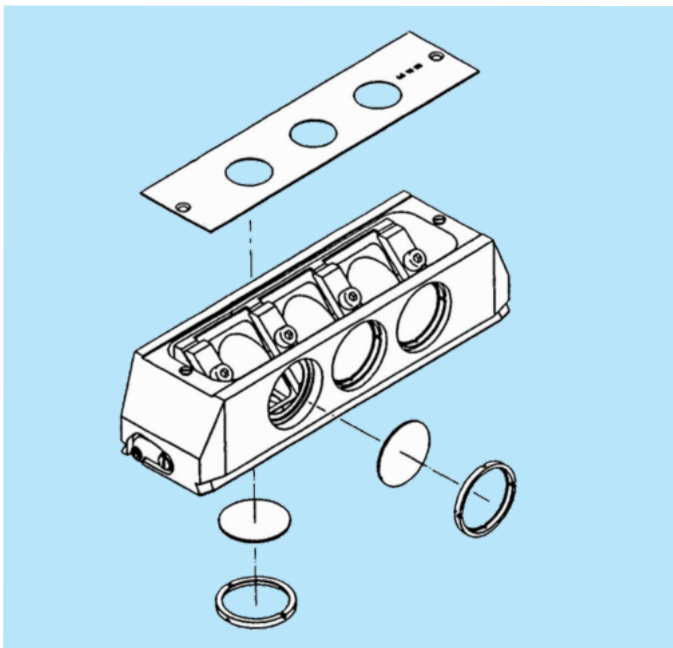
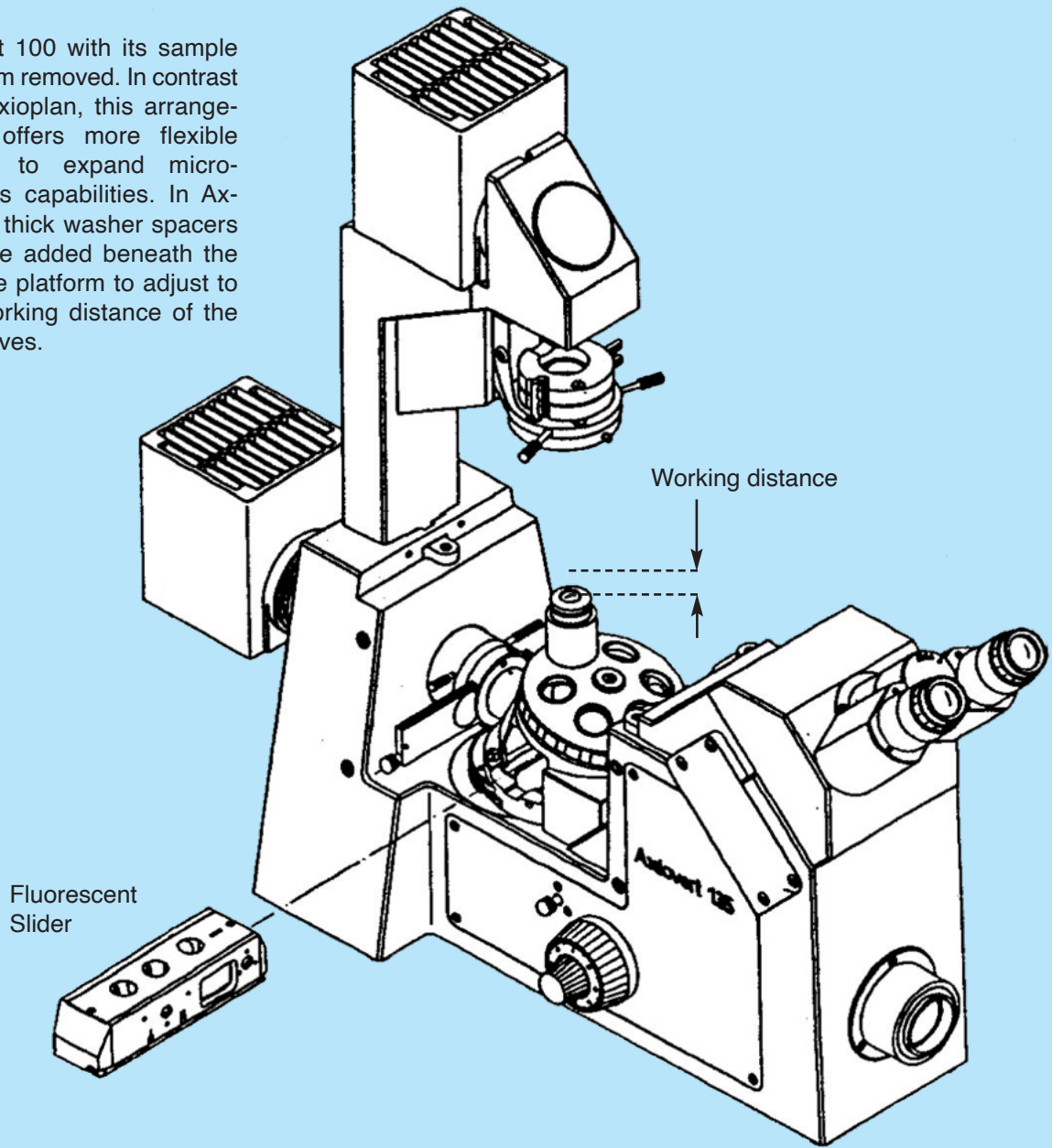

Swivel Design

Side view of Axiovert 100 shows its versatile design, allowing the illumination column to swivel out of the way for more convenient sample placement or removal. This position also allows easier access to the optics, i.e., to replace condenser optics.

Swivel design is not trivial in optics. It requires an elaborate, heavy duty hinge with stops at both ends.



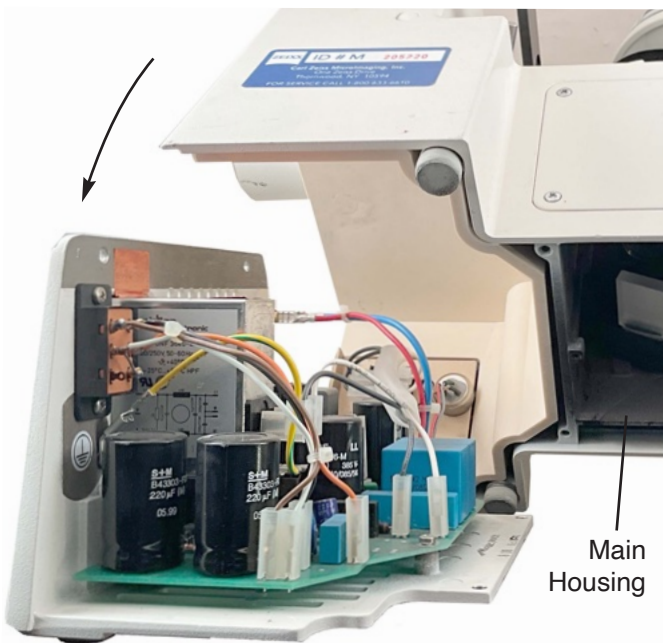
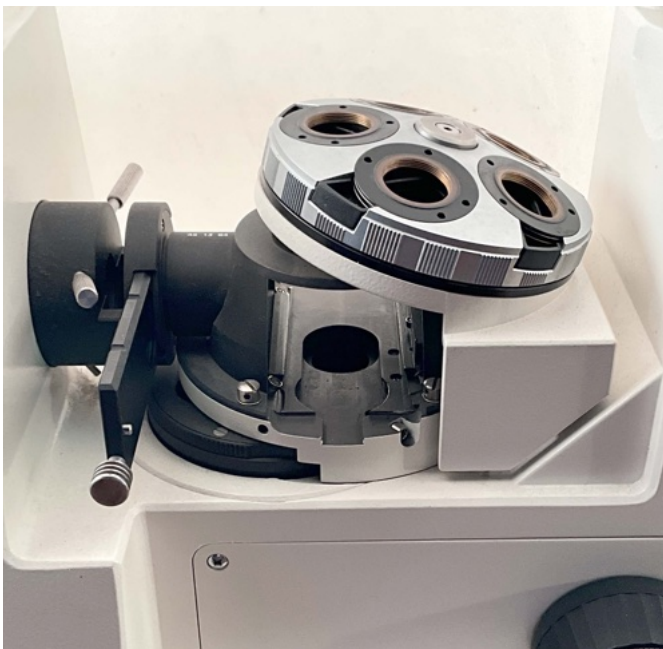
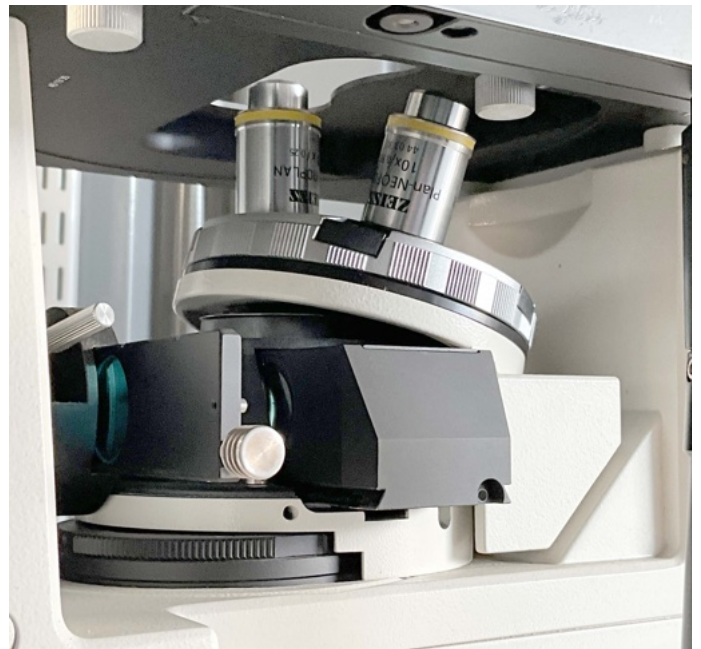
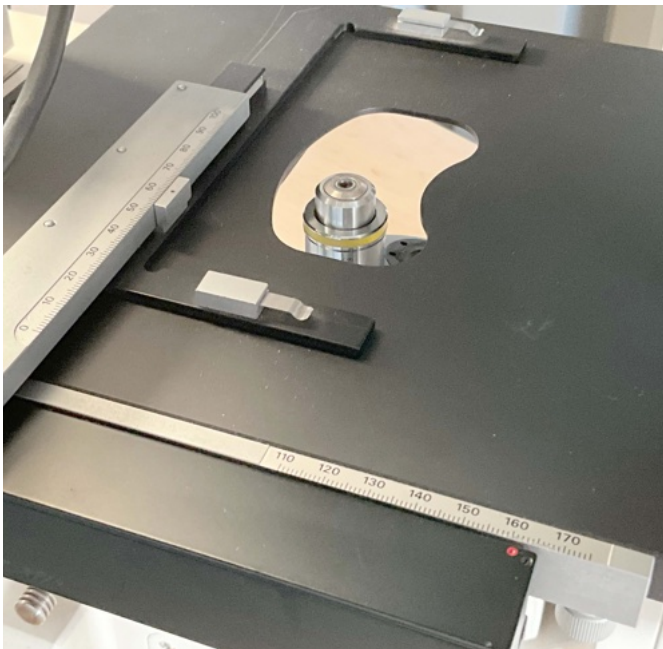

Main Housing



12V Halogen lamp with power supply (left) embedded in the pyramid (as Zeiss calls it) portion of Axiovert 100's body design. Compared with Axioplan 2, for lack of having motorized stages, and sophisticated electronics, this power supply has huge reduction in size.

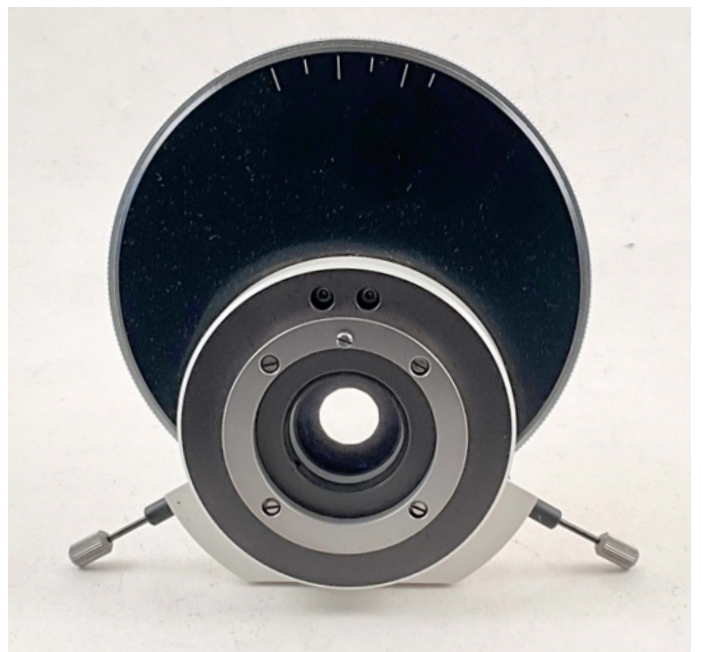
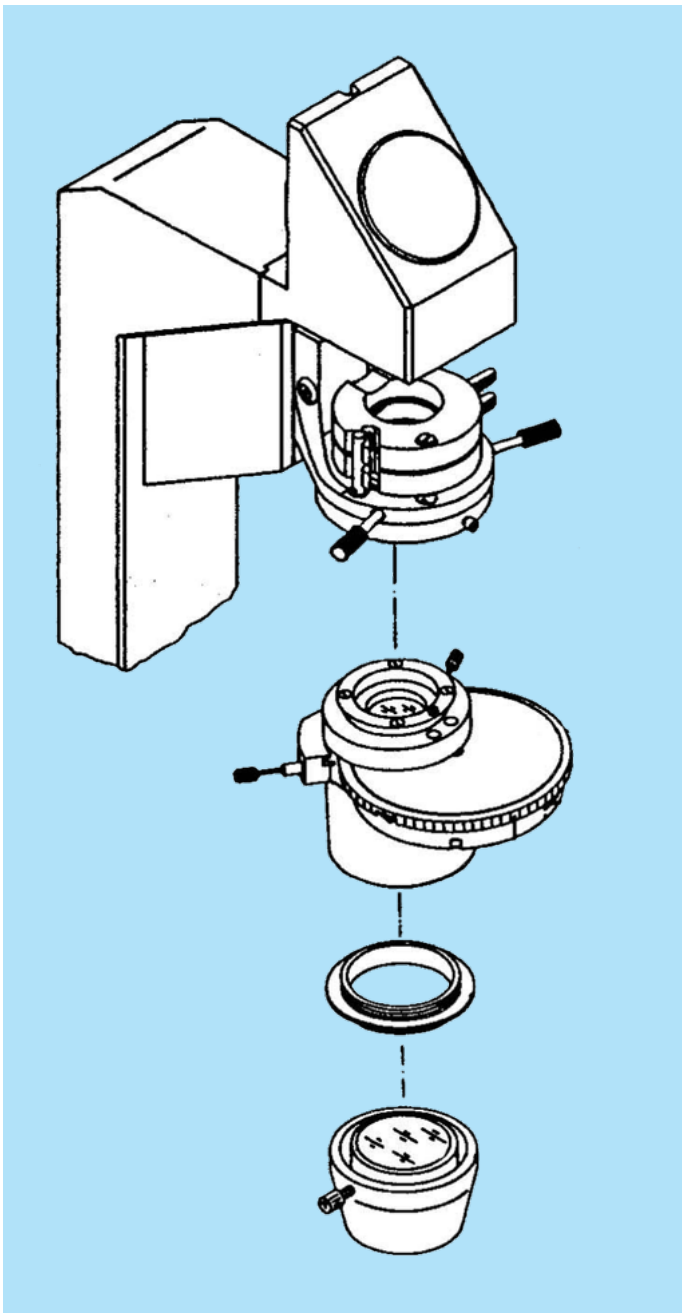

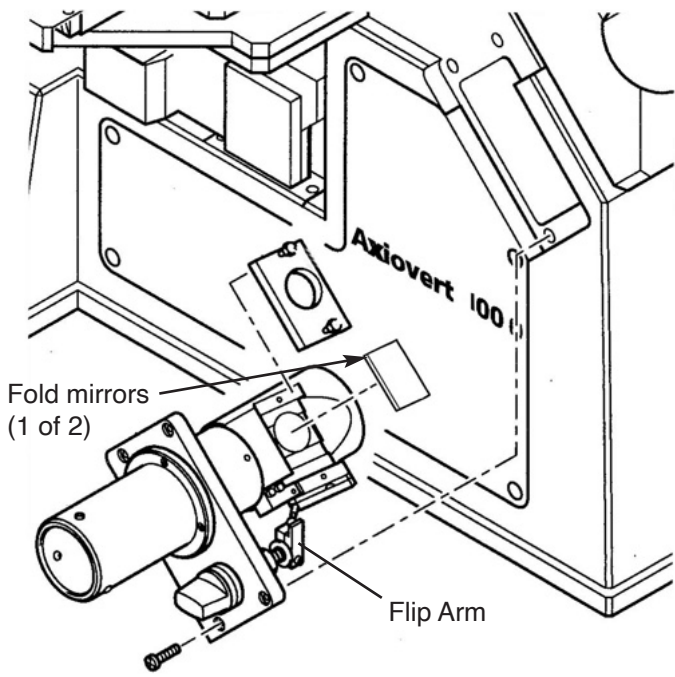

Looking inside the body of Axiovert 100, you'll see a lot of empty space (bottom) simply because this particular design requires an optical bench-like platform to freely bounce beams inside the casing to divert to a camera or the eyepiece. The flip mirror (below/left) beneath the binocular head has an interesting design. The mirror on this mechanism is interchangeable.

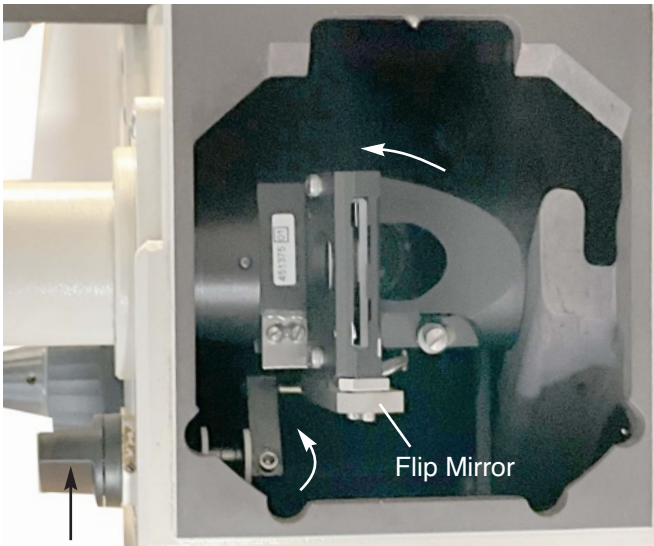
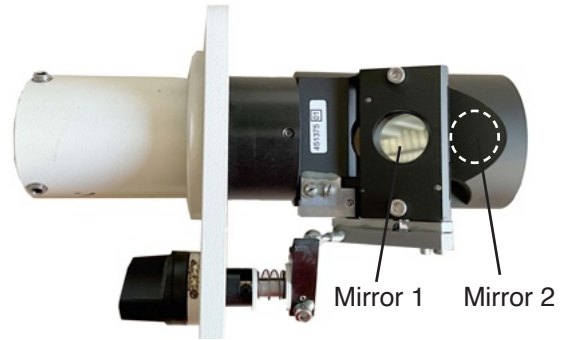

Light path is cleared to reach the eye

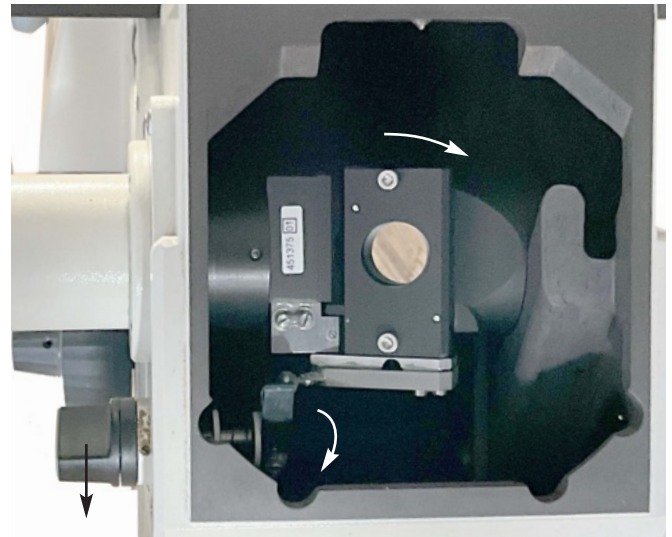

Light deflected to the camera

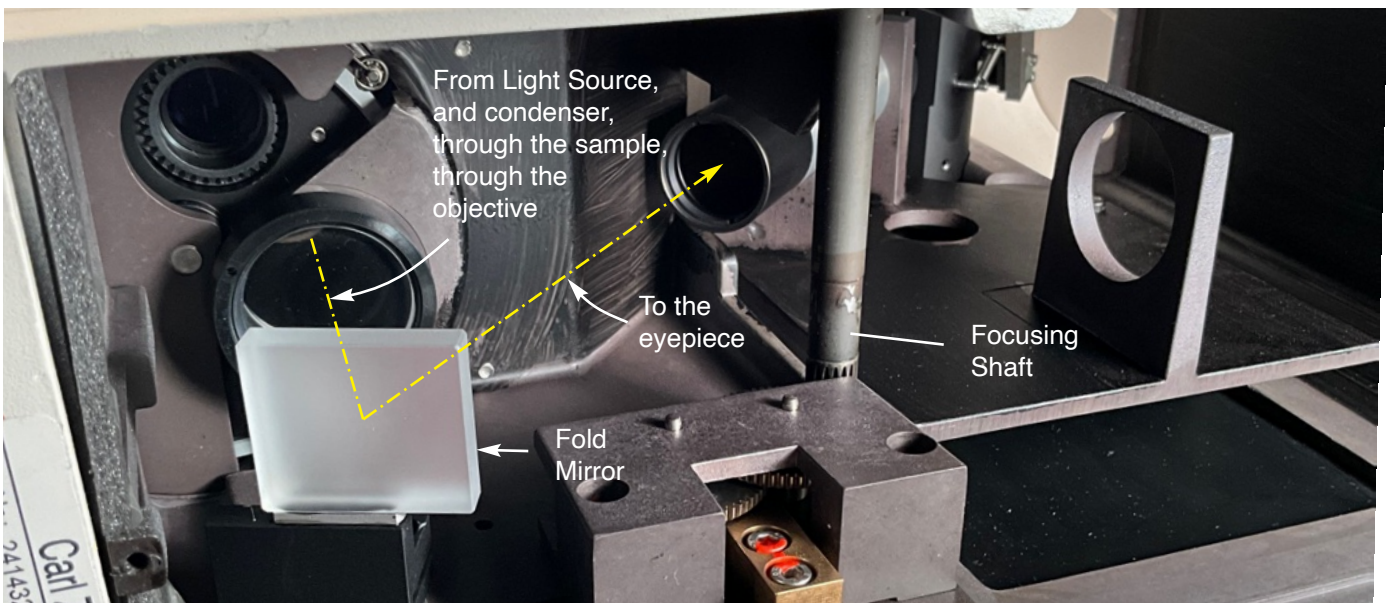

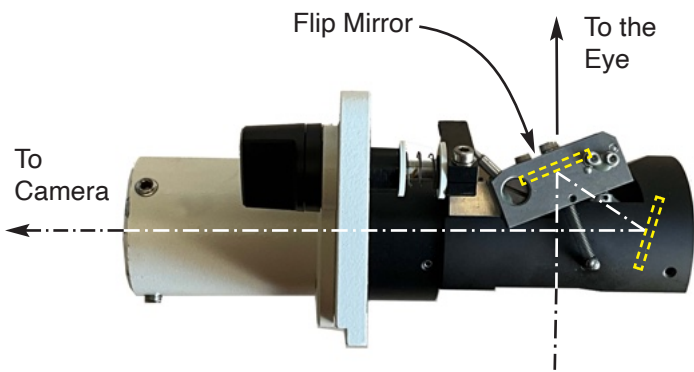

Side view of flip mirror mechanism: The beam from the objective is diverted to the eye or to the camera.

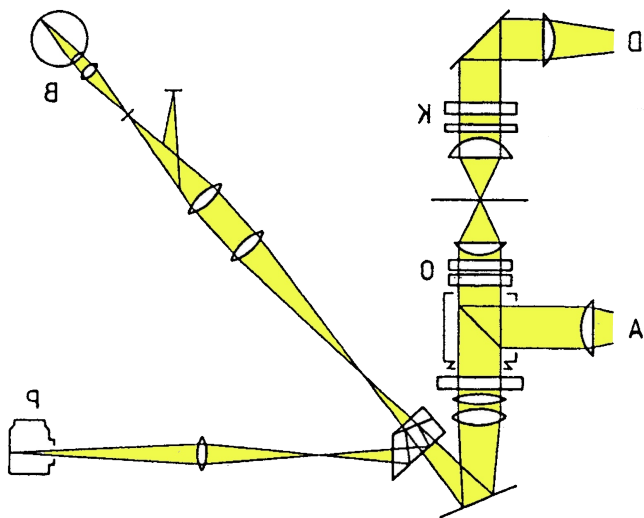

Light path inside the Axiocvert takes up space to implement.



1953–1959 — Zeiss Standard Microscope Line

- Designers: Dr. Peter Siedentopf, Helmut Naumann, Dr. Max Berek (earlier optics legacy)
- Upright transmitted-light microscopes (Standard, WL, GFL)
- Finite 160 mm tube length system

1962–1974 — Zeiss Universal & Photomicroscope

- Designers: Dr. Peter Siedentopf, Dr. Dieter Gerlach (young engineer then)
- Introduced modular reflected-light system & DIC (Nomarski)
- Set foundation for later Axioplan modularity

1978–1982 — Concept work on “Axioline” program (new infinity system)

- Zeiss Oberkochen optics team led by Dr. Hans-Joachim Haase
- Goal: universal infinity-corrected system (ICS = Infinity Color-Corrected System)
- Early prototypes tested under code name “AXIO 1”

1983–1986 — Development of Axioplan (upright) and Axiocvert (inverted)

- Optical design: Dr. H.-J. Haase, Dr. Dieter Gerlach, optical group (Oberkochen)
- Mechanical design: Hans Kurz, Wolfgang Ehret
- Industrial design: Hartmut Esslinger / frogdesign + Zeiss internal design office
- ICS infinity optics ($f = 165$ mm tube lens) standardized
- 1986: Commercial launch of Axioplan and Axiocvert 100

1990–1992 — Axioplan 2 / Axiocvert 135 / Axiocvert 200

- Upgraded optics (ICS²), video adapters, fluorescence refinements
- Continued design evolution at Zeiss Oberkochen

2004–2005 — Axio Imager (successor line)

- Chief designer: Zeiss Optical Systems group (Dr. Jürgen Kleinschmidt)
- Integrated motorization, digital imaging

How to talk to God

By Ali Afshari

A human being is not a single self, but a gathering of many selves. We are the witness of these inner multitudes — each with its own desires, fears, and longings. To live consciously is to recognize that we are not what we temporarily become. We may feel anger, yet we are not anger itself. We may drown in our work, yet we are not our work. We may feel jealousy or desire, yet we are not those impulses. We are the observer—the one who experiences these forces passing through.

Rumi wrote that these emotions are preoccupations of the mind, distractions that make us forget who we truly are. He likened us to the reed flute—cut from the reed bed, separated from its source, and crying out in song for reunion. If we learn to release all that arises within us—every thought, emotion, and mask—something beyond what we see will begin to appear. We must, he said, cut the ropes of the mind and withdraw from the veil of thought.

“Hear the story as told by the reed, for being separated. Ever since I was cut from the source, I long to return. Anyone pulled from his source longs to go back. Anyone apart from whom he loves understands what I say. At any gathering I’m there, mingling in the laughing, and grieving, a friend to each, but only few could hear the secrets hidden within the notes. No ears for that. The reed flute is a friend to all who want the fabric torn, and drawn away. It’s not given us to see the soul. The one who secretly hears this is senseless.”

To be human, then, is to experience fully all that life gives—without clinging, without denial. The other day, I saw an elderly couple in their seventies loading groceries into the trunk of their car. I said to them, “I wish...” The wife asked, “Wish what?” I replied softly, “I wish that one day my wife and I could live to be like you.” They smiled warmly, and in that small exchange, gratitude passed silently between us—gratitude for love that had endured the years.

I find beauty in such moments. When I walk through a toy store and see children’s dolls, my face lights up. I think of the children who will soon hold them, giving back in play all the love they have received from their parents. Those of us not preoccupied with survival cannot ignore the images from Gaza. Yet we have been taught to fight only for personal success—to believe that life is a race for individual advancement. This, I believe, is a false education. We, the human race, are a much closer family than we realize. Those who understand this truth live with a deeper sense of meaning than those who do not.

I think of my brother during the American recession of 2008. He lost his fifty-million-dollar business, his mansion, his office, his wife’s jewelry in the bank deposit box—everything. Around that time, I watched the documentary Rachel, made by an Israeli filmmaker about the death of Rachel Corrie. According to the film, all the security



Rachel Corrie, and Aaron Bushnel Gave their lives for Palestine while we stood aside, and looked.

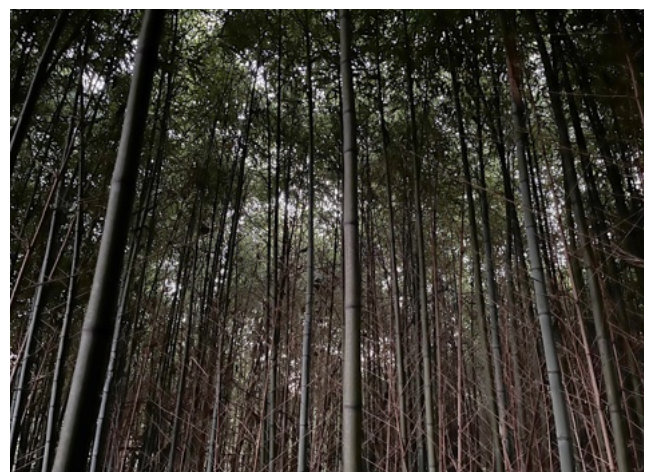

The reed spends more than four years growing its roots in the soil—years of invisible preparation before it ever rises above the surface.



The way to speak with God begins with understanding how the prophets spoke to their source. Ibrahim and Moses are luminous examples. Do not copy the words of others when seeking God. As far as I know, God does not favor one group or people over another. God, I believe, has a delicate heart—and like all delicate hearts, it must be stolen gently, through sincerity.

footage from that day was either erased or missing. Rachel was killed while trying to stop a bulldozer from demolishing a Palestinian home. At that time, more than 250,000 Palestinian homes had been demolished for being built “without permits.” The tragic irony was that no permits were ever granted to Palestinians at all.

After the film, people gathered outside the theater. Someone asked, “Why do we have such a bad economy now, losing our homes here in America? We worked so hard, and now the banks are taking them.” I answered, “When they were taking down homes in Palestine, we didn’t react because we thought it was only happening to them. But now, it’s happening to us.” Our indifference has a way of circling back.

Centuries ago, the Persian poet Attar of Neyshabur told a story that speaks to this blindness and awakening. In *The Conference of the Birds*, the world’s birds gather in despair: the world has no king, no guiding spirit. Each bird cries out for justice, love, and meaning. Then the Hoopoe, the bird with the golden crown, rises from the crowd. Wise from serving the prophet Solomon, he says, “O birds, beyond the mountains of Qaf lives the Simorgh (meaning 30 birds in Farsi), the King of all creation. If we can reach Him, He will give us the truth we seek.”

The journey seems impossible—across deserts, oceans, and mountains. But the Hoopoe urges them on: “Do not fear. The path to the Beloved is not for the faint-hearted. You must lose everything—even yourselves—to find Him.” When they finally reach the mountain of Qaf, only thirty birds remain—worn, bare, and emptied of ego. They call out for the Simorgh, expecting a radiant king. A silence falls.

Then a mirror appears before them. And in that mirror, they see themselves. “We are the Simorgh!” they cry. “We have been the One we sought.” In that instant, all separation vanishes. The thirty birds become one. The drop returns to the ocean. The seeker and the sought are the same.

To be one with humanity—with those suffering in Gaza or anywhere else—we must remember that our stories are connected. We lack that sense of shared past, and each time we disappear into the small screens of our phones, the distance grows wider.

Our mobile devices, for all their promise, have become addictions—tools of distraction that steal the time we could spend building real bonds, friendships, and acts of love. We have never been more connected, yet we have never felt so lonely.

Perhaps it is time to remember, as Attar wrote, we are the feathers of the Simorgh—to rise above the fog of separation and rediscover our shared humanity. To live as one is not to lose ourselves, but to find our truest being—the being that has always been whole. This awareness gives us hope, and true inner peace we desperately need. God is in charge, and observes everything—no worries.



Rumi often wondered about the origin of that subtle music that plays within us. Who is the one that hears it? Who is the one who watches?



The observer finds himself hearing constant inner dialog between our different identities. If we take sides, we’d confuse ourselves with that inner voice. Are these voices really us? What if they are all strangers to who we are? What if we are associating with the wrong crowd like we sometimes do in the outside world?

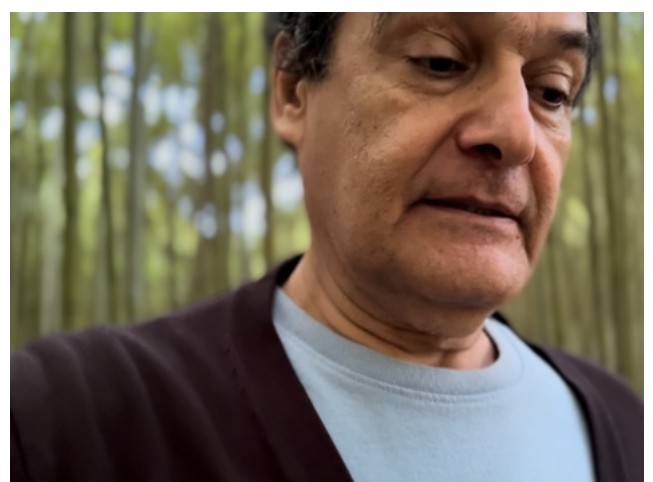

I truly believe God is looking for the extraordinary being among us. The purpose of building Princeton, MIT, and Caltech wasn’t meant for ordinary students. It was built to give rise to another Einstein. When the world gets too ordinary, the universe will remind us God awaits for the extraordinary. That’s why God is silent about Gaza.

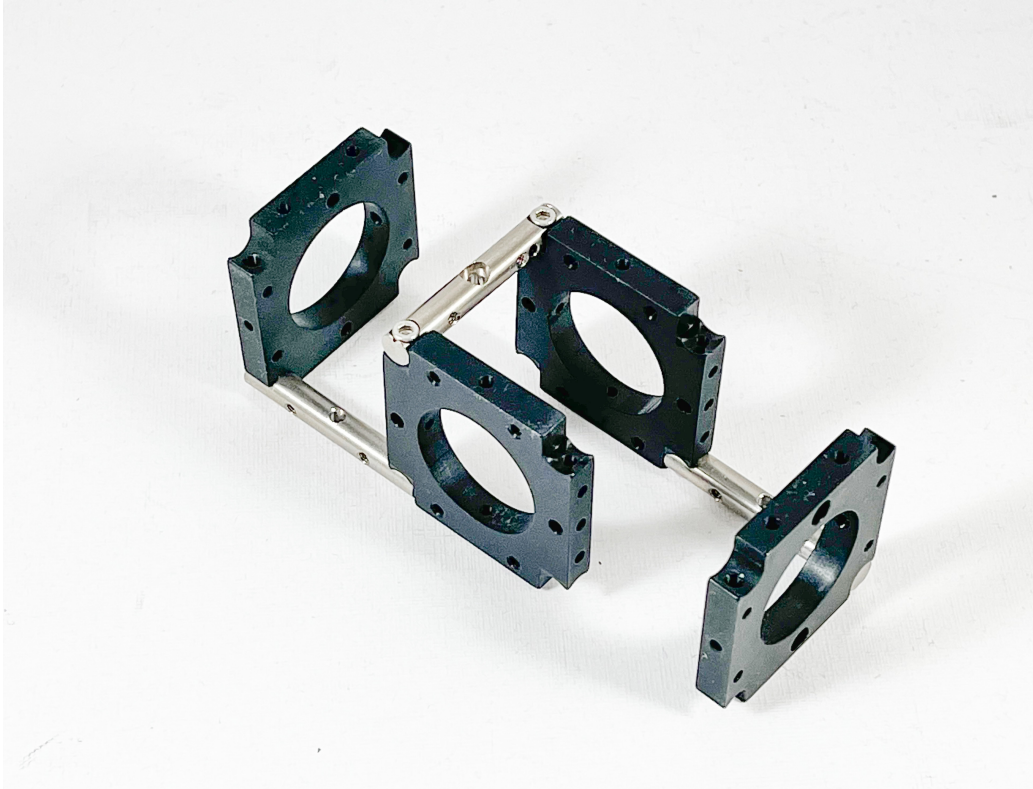

Our Instruction Manuals

Optoform's user's manuals have been compiled to follow the tradition of optical erector sets. Every page is lavishly illustrated to show how each instrument is designed, and assembled together. As your knowledge of Optoform increases, so does the level of sophistication in your assemblies. Download from:

www.optoform.com

info@optoform.com