

Optomechanix

Zeiss Micro Interferometer
Goto Optical Planetarium
Digital Planetarium
OMiD Planetarium
The Art of Spindler & Hoyer
God's Hope in Movies

The Planetarium

April-June 2026



Technical journal of OMiD, Opto-Mechanical Institute of Design



Zeiss Micro-Interferometer inside its protective case at OMiD museum. I can't hide my passion for opto-mechanics specially when having full access to an optics museum. Sometimes something catches my eyes, and I pick it up, and spend time with it to see if it would make a good article. One of the most overlooked instruments was this Zeiss interferometer that I had kept away for later. I finally noticed it, and so quickly I discovered something very special in my hands.

I have worked on so many opto-mechanical instruments, but I would grade this to be among my top 10. I have never seen it laying around at museums, and I wonder why. Perhaps it's a hidden treasure that no one ever paid much attention to. I also looked at many technical journals, and there was hardly any mention of it, and if there was, it wasn't because someone actually studied it. It was mostly a guess work, and how it looked like to be instead of what it actually is.

Contents

Page

Introduction	3
Zeiss Micro Interferometer	4
Polarization Optics	14
Disassembly of the Instrument	12
Goto Optical Planetarium	20
Digital Planetarium	25
OMiD Planetarium	27
The Art of Spindler & Hoyer	29
God's Hope in Movies	34

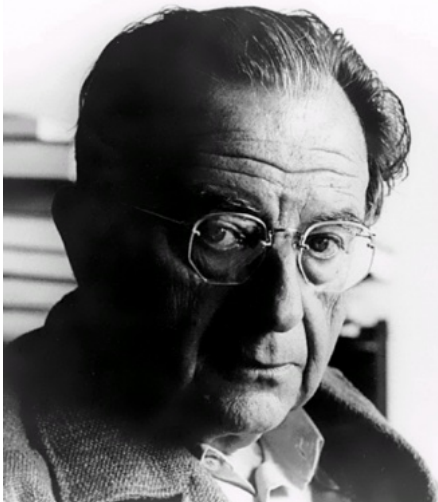

Erich Fromm 1900-1980

This issue Dedicated to:

Erich Fromm (1900-1980) was a German-American social psychologist, psychoanalyst, sociologist, humanistic philosopher, and democratic socialist. He was a German Jew who fled the Nazi regime and settled in the United States.

He began his own clinical practice in 1927. In 1930 he joined the Frankfurt Institute for Social Research and completed his psychoanalytical training. After the Nazi takeover of power in Germany, Fromm moved first to Geneva and then, in 1934, to Columbia University in New York. Fromm belongs to a Neo-Freudian school of psychoanalytical thought. Fromm at the time became strongly involved in Zionism. But he soon turned away from Zionism, saying that it conflicted with his ideal of a "universalist Messianism and Humanism"

He became a professor at the National Autonomous University of Mexico UNAM in 1949 and meanwhile, he taught as a professor of psychology at Michigan State University from 1957 to 1961 and as an adjunct professor of psychology at New York University after 1962.

He taught at UNAM until his retirement, in 1965, and at the Mexican Society of Psychoanalysis (SMP) until 1974. In 1974, he moved from Mexico City to Muralto, Switzerland, and died at his home in 1980. Fromm was reportedly an atheist but described his position as "nontheistic mysticism".

All the while, Fromm maintained his own clinical practice and published a series of books. He suggested a theory of personality based on two primary needs: the need for freedom and the need for belonging. He was known for blending Freudian psychoanalysis with Marxist social theory. His theory of personality explains that four character types are unproductive, and only one is productive: 1) The receptive type is characterized by a need for constant support. 2) The exploitative type is willing to lie, cheat, and manipulate others in order to get what they need. 3) The hoarding type copes with insecurity by never parting with anything. 4) The marketing type looks at relationships in terms of what they can gain from the exchange. 5) The productive type is a person who takes their negative feelings and channels the energy into productive work.

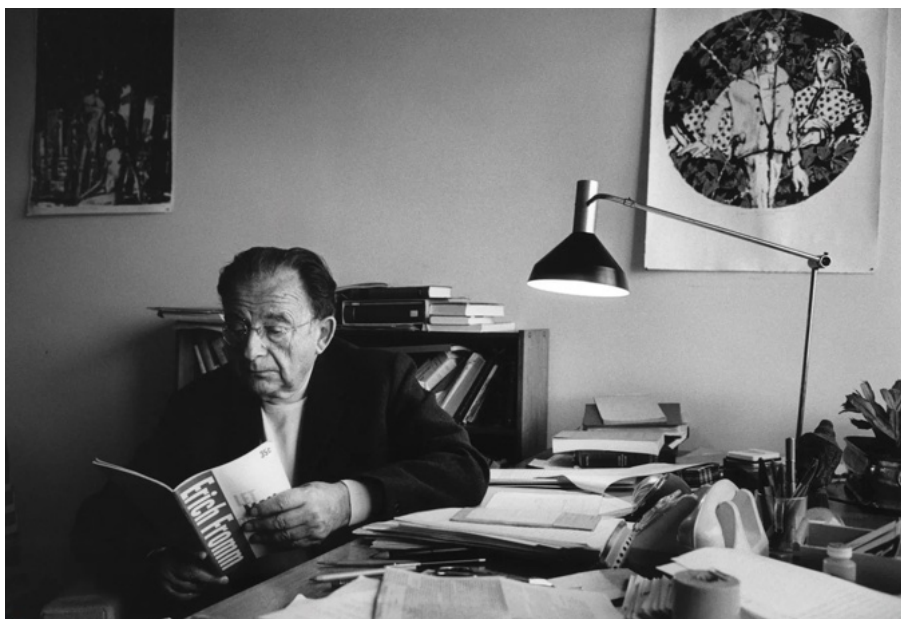

Copyright 2026

Web: www.optomechanix.org

Instagram: [optomechanix](https://www.instagram.com/optomechanix)

For digital subscription or suggestions email us at:

info@optomechanix.org

Chief Editor: Ali Afshari

Web Designer: Mojtaba Moradli

Optomechanix is a quarterly journal of Opto-Mechanical Institute of Design (OMiD), with technical articles for practical, hands-on opto-mechanical engineers. This magazine is privately founded.

Cover page photo: Zeiss Planetarium model VI TD, Inclined dome design, projects 8,900 stars

Front back: Zeiss interferometer on its wooden cabinet, and plexiglass cover

In This Issue ...

Technical writing is really an art, and as my teacher once told me, there aren't many of us left. I hope you'll enjoy this issue as I equally enjoyed studying them all. I have many years of experience behind me to disassemble instruments, but I have to confess, studying the Zeiss interferometer reminded me of a past glory that is long forgotten by today's consumerism. I have worked at JPL, and I could tell you not even some of our satellites are made this good. The only industry who has resisted the "Made in China" influence is the watchmaking world.

We have so much to cover in this issue. The classic optical components, rails, and accessories of Spindler & Hoyer has always caught eyes of opto-mechanical enthusiasts. We are going to cover their great contribution to classical field of opto-mechanics utilized in optics labs as well as their strong influence in modern optical engineering labs. The other fascinating instrument we are going to cover is Carl Zeiss micro interferometer. This heavy block of diecast construction has a complex design buried inside that will amuse any opto-mechanical engineer, or enthusiast alike.

Opto-mechanics is an enormously diverse field. Although a telescope, microscope, spectroscope, interferometer, and an imaging lens is first built and tested in a lab, it is transformed into so many variations when it goes to the field. Imagine the design of a zoom lens inside a mobile phone, and how its optics should be sealed to reliably work inside a pool or jacuzzi, or the construction of the wide angle, and telephoto lenses installed on Cassini spacecraft, so it could withstand the harsh environments in space. The Hasselblad that was taken to the moon had invar rods between its lens, and film magazine to thermally maintain its focus outside of the earth's atmosphere.

In this issue we'll also examine the opto-mechanics of a planetarium whose focus is far less critical than other imaging systems. The planetarium is a reversed pinhole camera. Each tiny hole on the sphere of the planetarium projects the image of an inner central filament on the inside wall of a large dome. Large public planetariums have an array of imaging lenses around a 100 Lb sphere that project pinholes to accurately image stars to a much larger dome covering over a hundred seats. We'll show the clockworks of its mechanical design, and then cover a new digital version. In the end of the issue, we'll continue the three-part series titled: "God's hope".

Ali Afshari
Editor in chief
Optomechanix

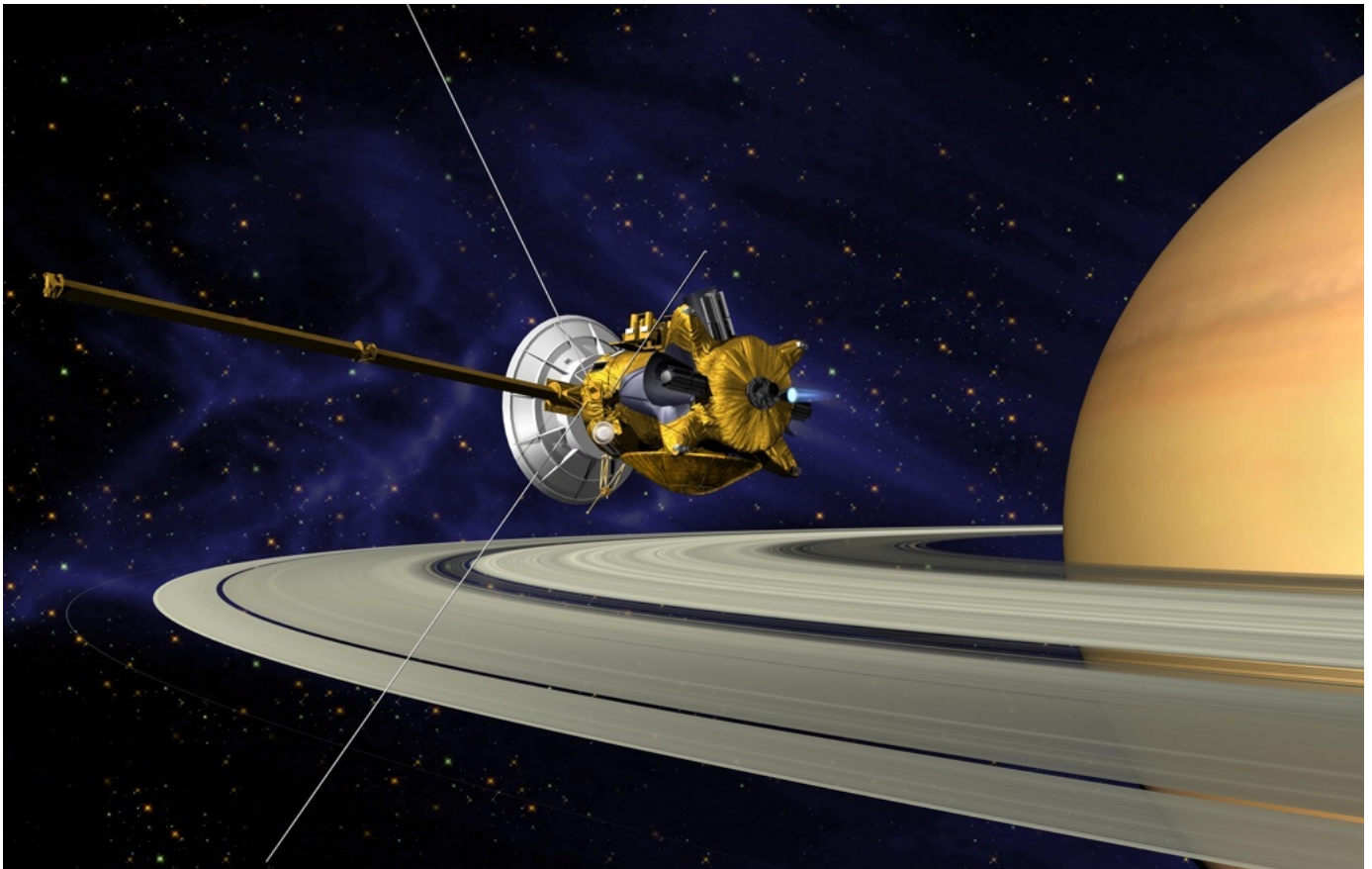

One of the most essential instruments of Cassini spacecraft were its optics, and sensors. The challenge of Optomechanics in space is its athermal factor. Its optomechanics should withstand temperature variations of 300 degrees C.

Carl Zeiss Micro - Interferometer

At first glance, it looks like a bulky, heavy weight microscope with nothing much in it. On the contrary, this instrument is loaded with mind-blowing opto-mechanics. The more you try to figure out its beam path, the more you'd ask yourself why? Why would Zeiss produce such a complex optical path, and beam directing control mechanism? At the end, you'd be convinced this is the cleverest way to do it!

This interferometer is intended to work as an inspection tool to map the microstructure of a rough sample (right), which is far more pronounced than micro-scale errors found on optical surfaces. But it also can work with laser light with a single frequency wavelength. This system works with a high voltage spectral lamp with a bandwidth of around 40 to 80 nm.

Linnik Interferometer

Zeiss interferometer is actually a modified Linnik design, requiring two objectives: One for focusing to the sample, and one to focus to a reference mirror. This is why a two set of objectives are installed on its turret (below). This is a more costly Linnik design.

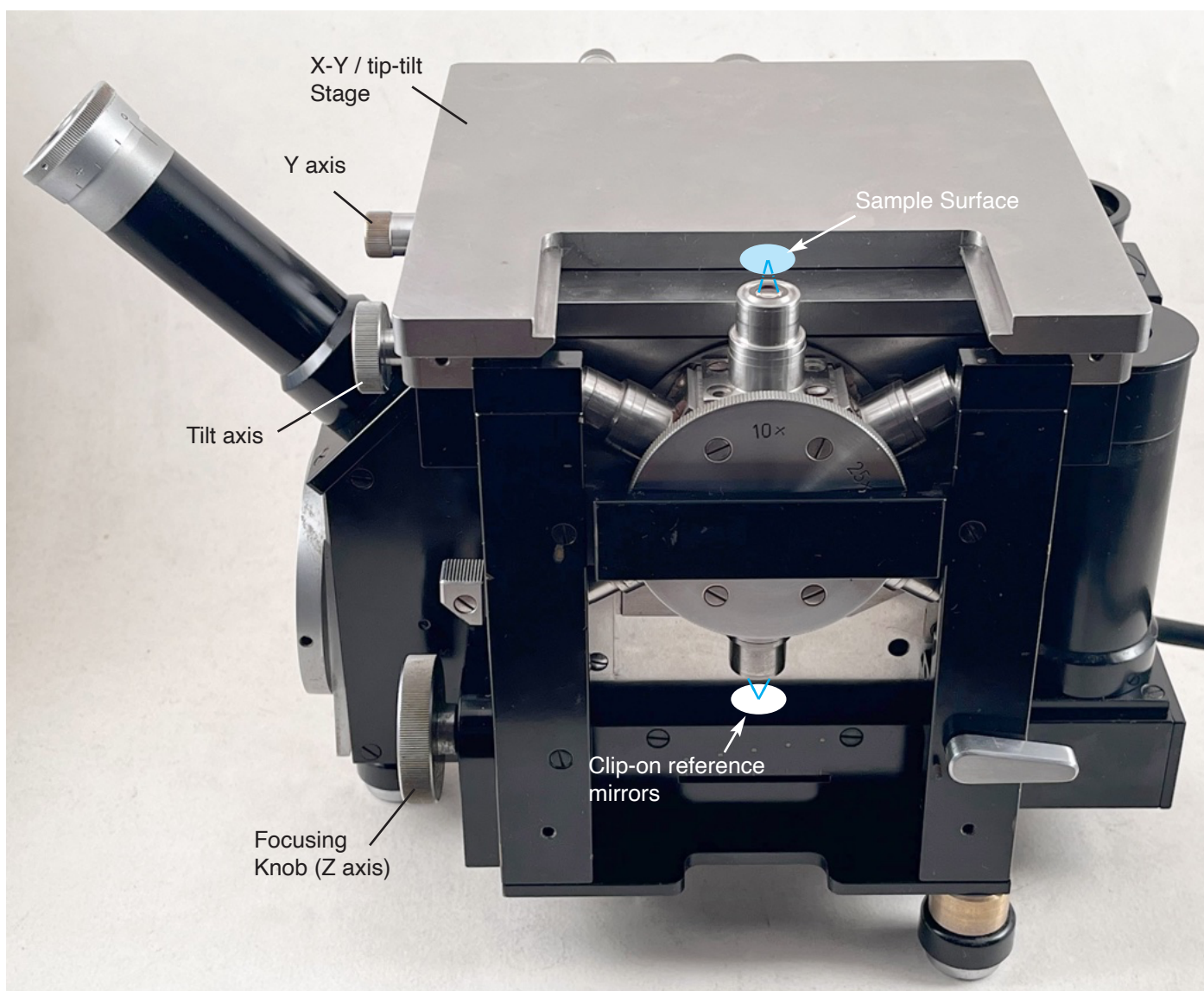
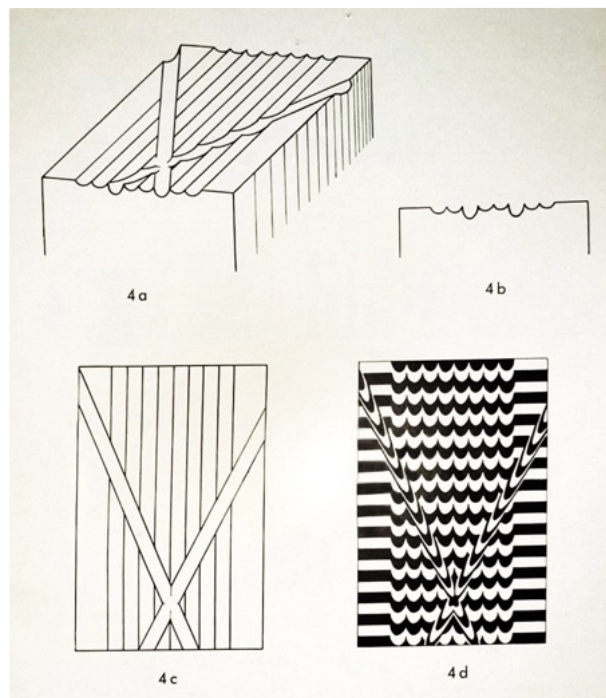

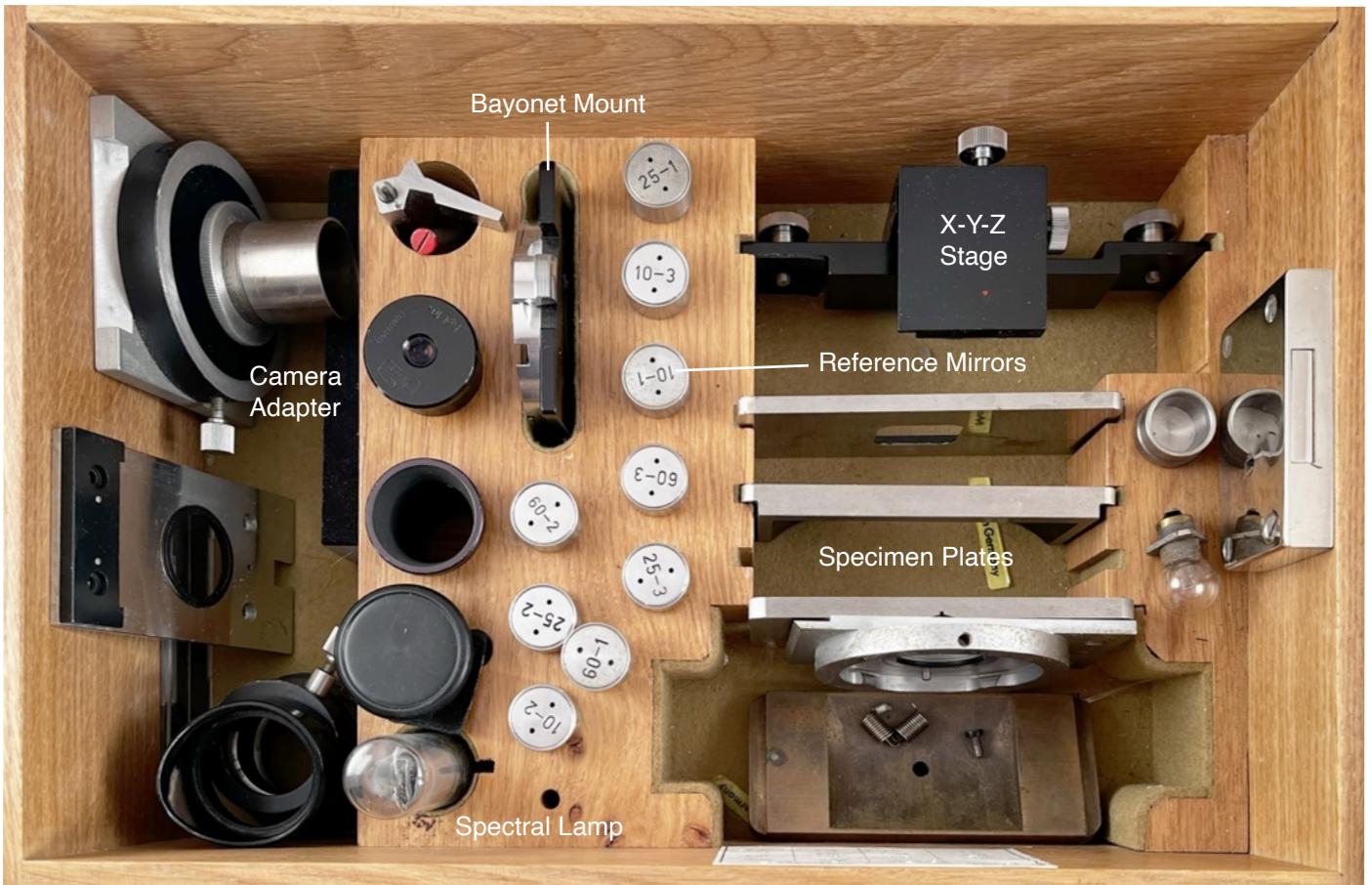

The Zeiss accessory box contains spare eyepiece, and various reflector caps for objectives (center), Camera attachment adapters (left), and various sample holding platforms (right). A spare Osram spectrum light bulb is also shown, and special tungsten light bulb (right) that align its filament for proper illumination coverage.

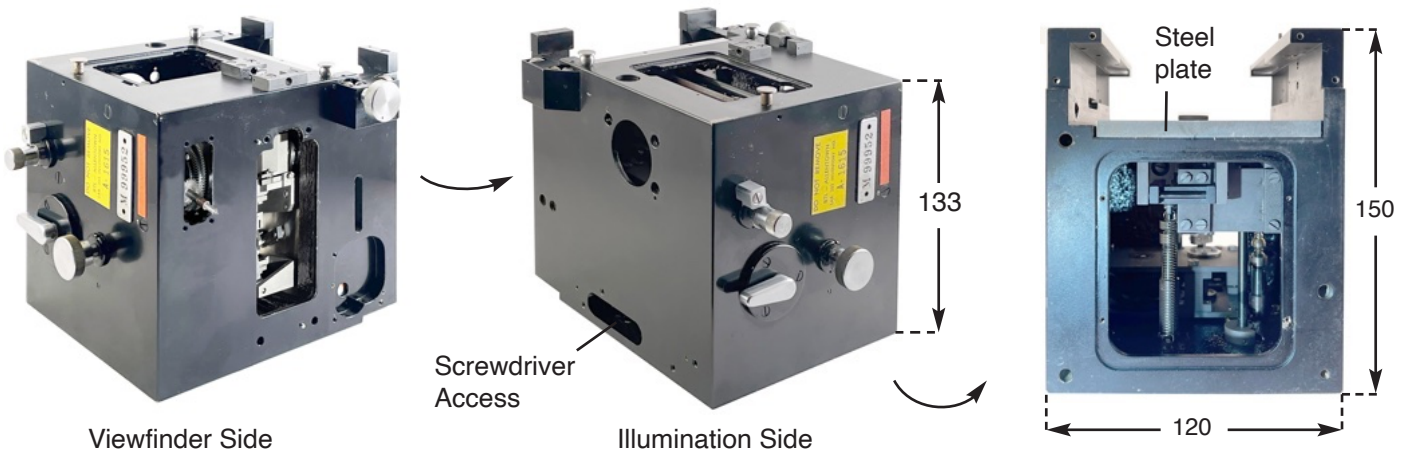

Zeiss uses a 7-Pound solid diecast block to house all its components inside this very tight space (right). Diecasting a solid block would have rough inner walls because you can't mill out the inside. Although the outside has been machined flat on all sides, but the inside remains rough like asphalt (right). The front side is machined to accept a large steel plate on the largest opening of the housing. The inner back wall has been machined at 4 points to mount a mechanism, and a spring hook. The front side where the steel plate is mounted, is machined parallel to the 4 machined points on inner back wall.

This design is tricky to put together, and it's like building a ship inside a bottle. Zeiss must have spent a fortune developing this design, so much that if you want to end up hating what China has done to Opto-mechanics, you should study Zeiss. This is an extremely well-built instrument.

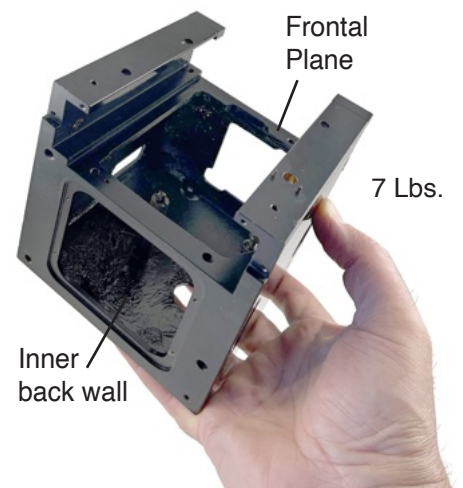

The Optical Design

In my study of this instrument, I kept searching for a mention of its design in so many published papers covering the Linnik interferometer but I couldn't find one. Many other references are made in Linnik related papers, but none have covered the Zeiss design. Finally, I found a similar design in a 2018 paper titled: "Modified Linnik microscope interferometry for quantitative depth evaluation of diffraction limited microgroove" by Research Center for Advanced Science and Technology, University of Tokyo. I would say one reason I could think of is, no one took the Zeiss seriously, plus it is such a hidden prism work that is buried inside a hard to take apart instrument. Well, now that I am taking the time to explain it, I hope some university papers would study, and refer to it.

One reason the Zeiss interferometer is so difficult to work with is that its components are all mounted inside a diecast block of steel, through hard to access holes like the inner walls of a tight cave. Many modern techniques featured inside the Zeiss, such as the flexure lift stage, and dual rotary wedge prism work were ahead of its time. Its dual light source, tiltable sample platform, X-Y and focusing stage, and control knobs are so cleverly placed around its cube form when the user sits behind the ergonomically angled observation eyepiece. A 35 mm Contax camera sits below the eyepiece for easy access to all its controls such as the advance knob, shutter speed control, and film rewind. This instrument would win awards for its clever packing of all these mechanisms inside a one-piece, solid 6"x6"x6" housing.

Just to be prepared for what's coming, here's is how the Linnik interferometer is explained in a paper titled: "White light interferometry for vertical artifact calibration", put out by National Institute of Microtechnology in Bucharest, Romania, 2008 SPIE Digital Library, Vol. 7007 70070J-1. Just read through it before we start studying the Zeiss.

Right, the principle of a Carl Zeiss microscope TIC shearing micro-interferometer is illustrated. The light emitted from the light source 1 passes the collector 2 and is circularly polarized by the circular polarizer 3. The plane glass reflector 4 reflects the circular polarized light partly to the prism 5. This results in a shear s in the object plane 9, which is far greater than the resolution limit (creation of a dual image split). The TIC prism 5 is dimensioned and arranged in such a way that the interference plane 6 does not coincide with the specimen exit pupil 7. This creates a dual pupil image and results in an interference fringe pattern in the field.

After reflection on the object, the two images, polarized at 90° with respect to each other, pass the lens 8 again, are reunited by the prism 5 and pass the circular analyzer 10. The resulting visible interference pattern is imaged through the tube lens 11 into the detector plane 12, as one can see in Fig. 7.

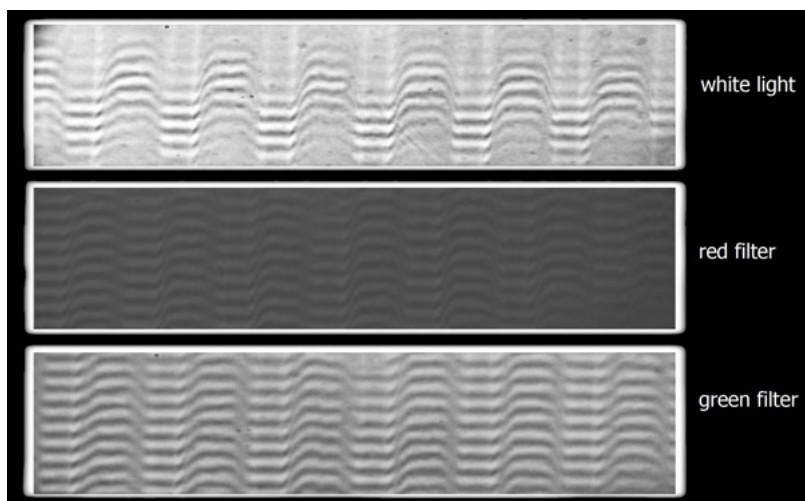
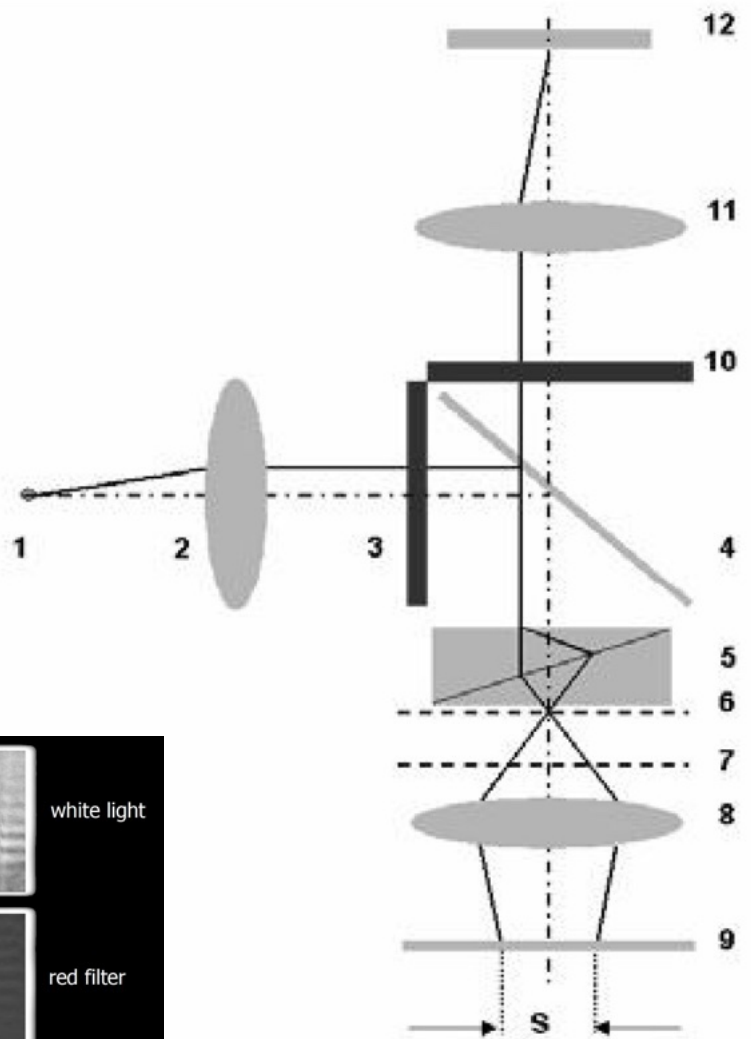

Left, A diffraction grating imaged through the Linnik interferometer. The height measurement shown on top is using whight light, and below are with narrow band filters.

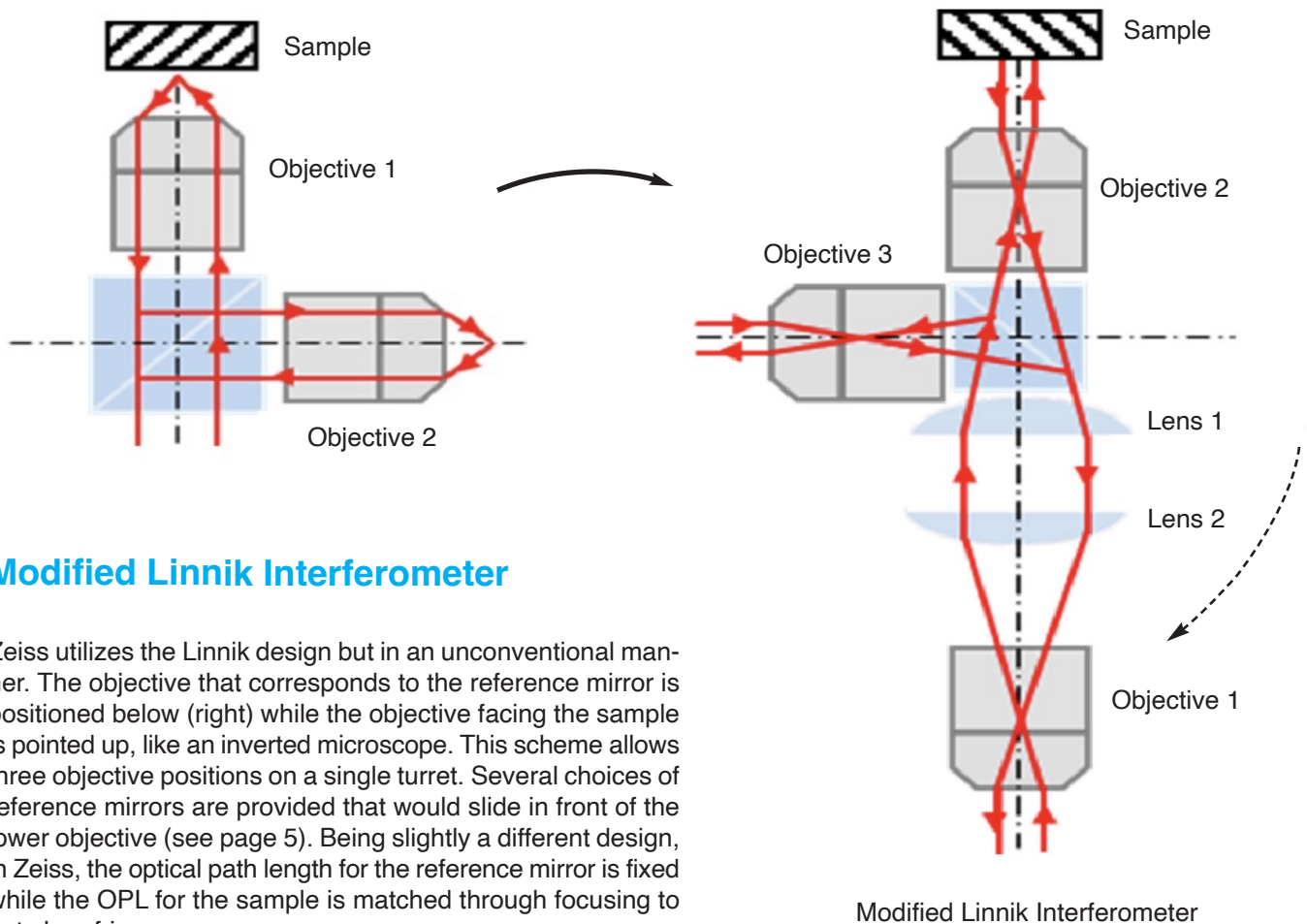
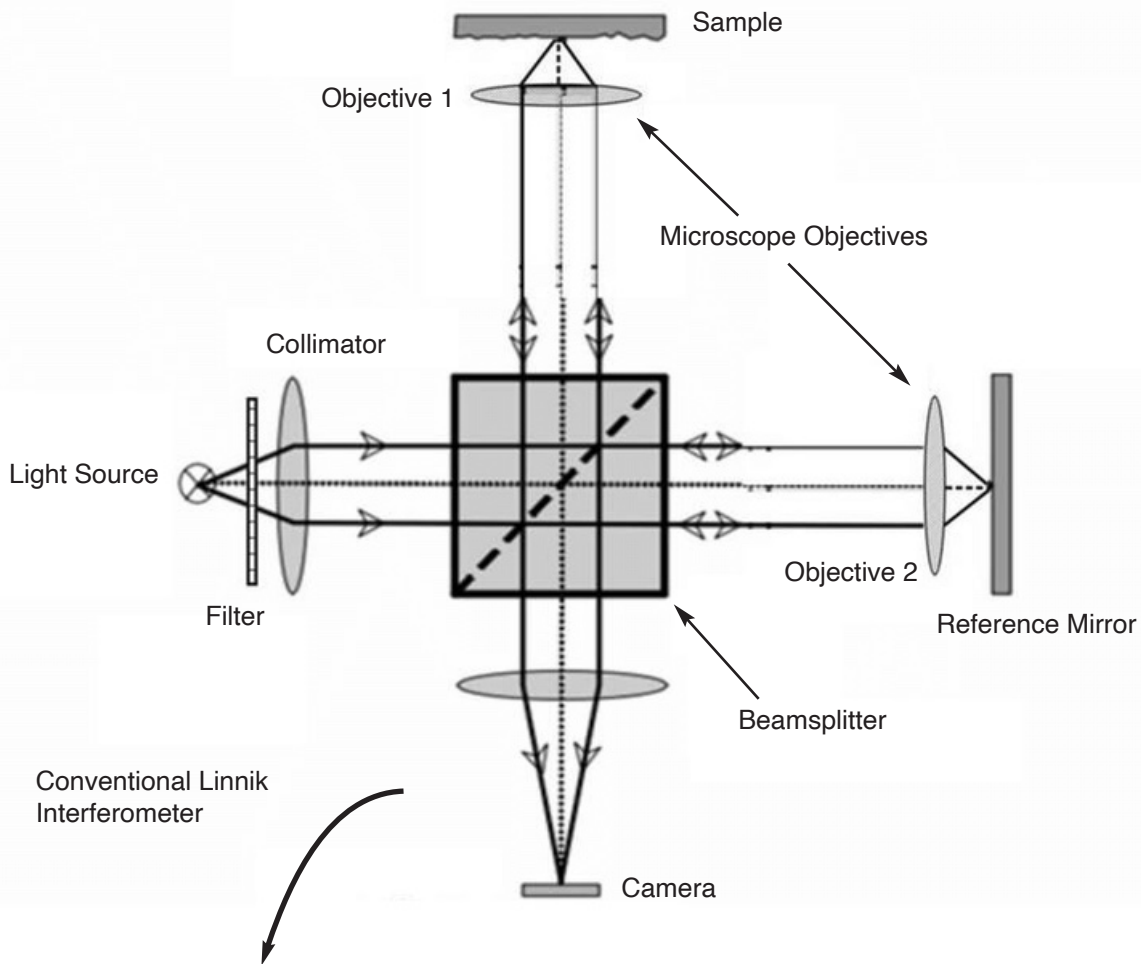

Modified Linnik Interferometer

Zeiss utilizes the Linnik design but in an unconventional manner. The objective that corresponds to the reference mirror is positioned below (right) while the objective facing the sample is pointed up, like an inverted microscope. This scheme allows three objective positions on a single turret. Several choices of reference mirrors are provided that would slide in front of the lower objective (see page 5). Being slightly a different design, in Zeiss, the optical path length for the reference mirror is fixed while the OPL for the sample is matched through focusing to get clear fringes.

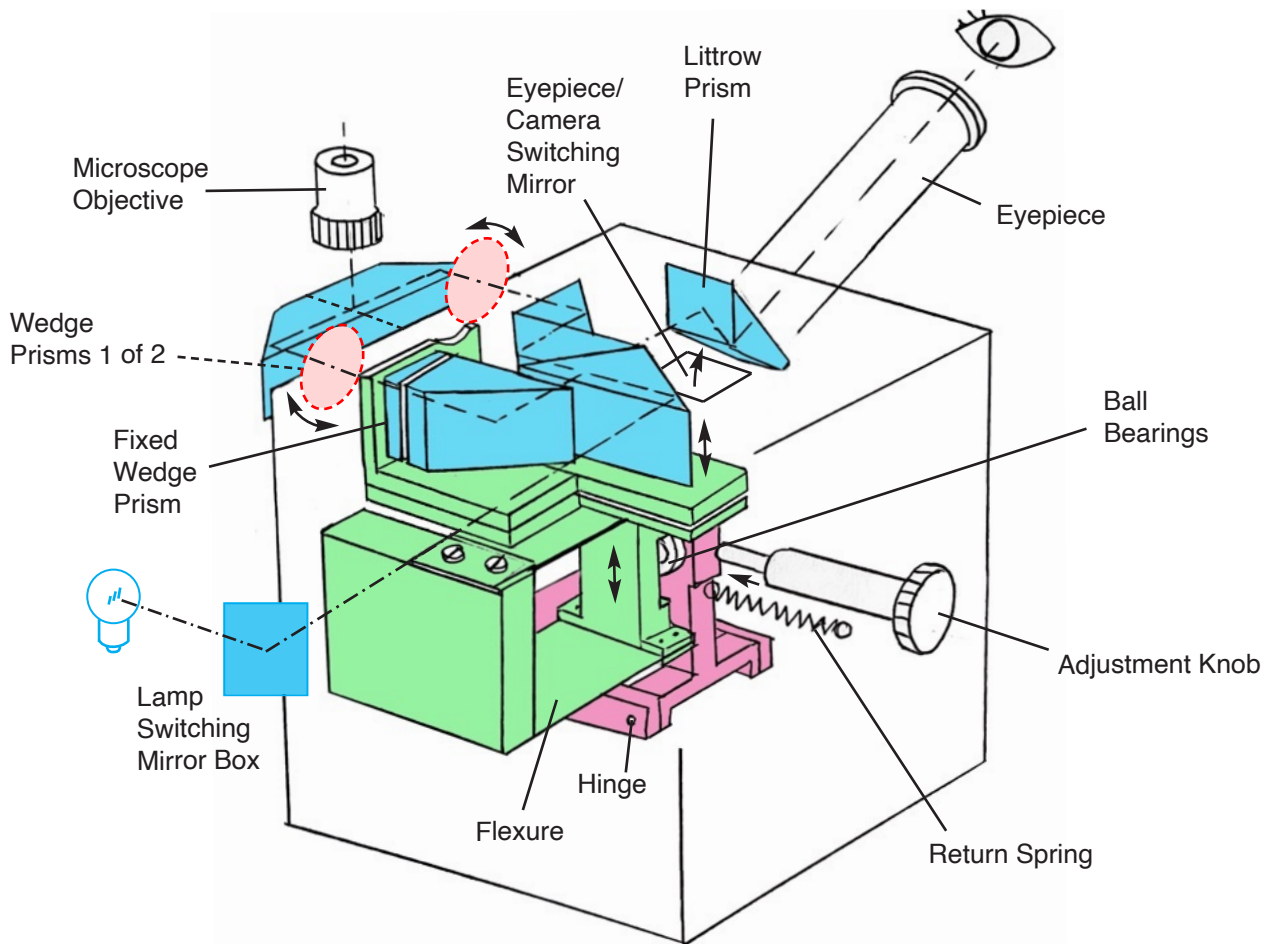

Interior Design: Complex prism work of Zeiss interferometer splits the lamp light into two beams, then diverts them into two separate microscope objectives, each facing the sample, and a reference mirror. The reflected beams are combined together to produce interference fringes. A notable feature is the rotating wedge prisms (above) instead of tilt stages to control the two-beam overlap to produce fringes. A top view of the beam path is shown below.

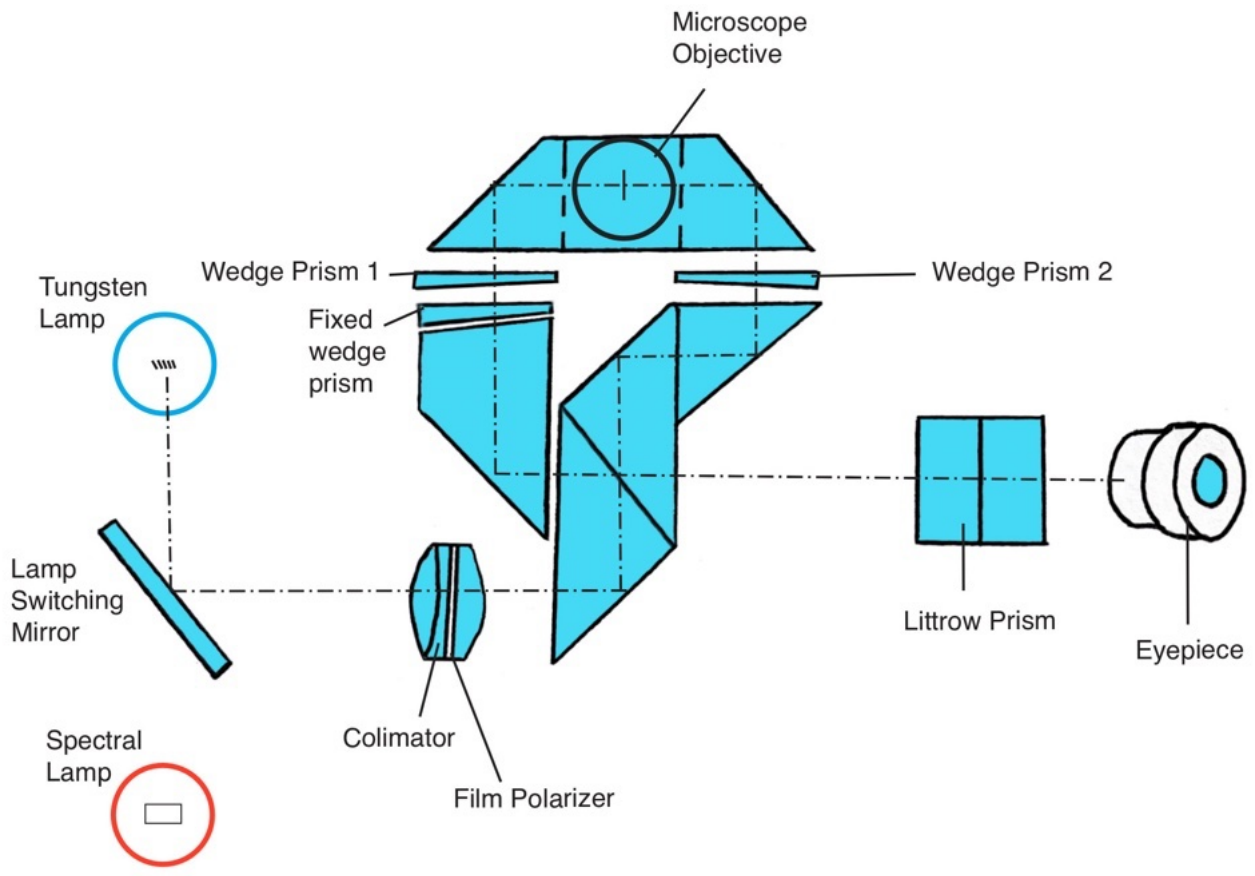



Above, the control knob that to control fringes rotates two independent wedge prisms as shown in section drawing below. This knob rotates a coupling gear that can rotate simultaneously both wedge prisms as well as rotating each individual wedge prism. While most interferometers utilize fold mirrors to overlap beams to produce fringes, Zeiss uses wedge prims by utilizing a three-gear mechanism to be able to control the fringes in this unique combined/independent way.

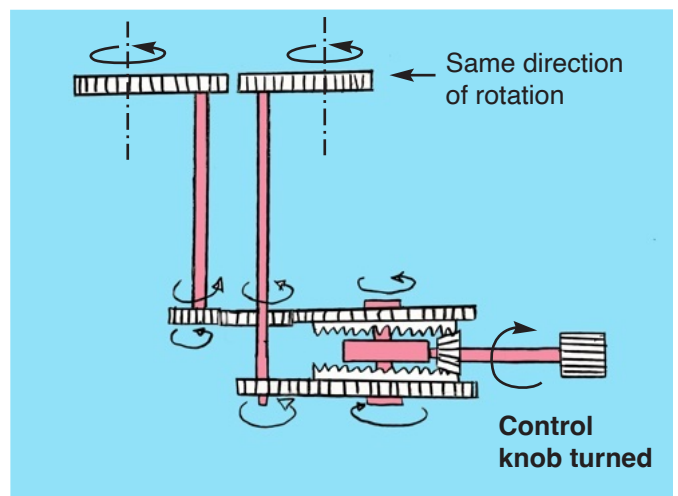
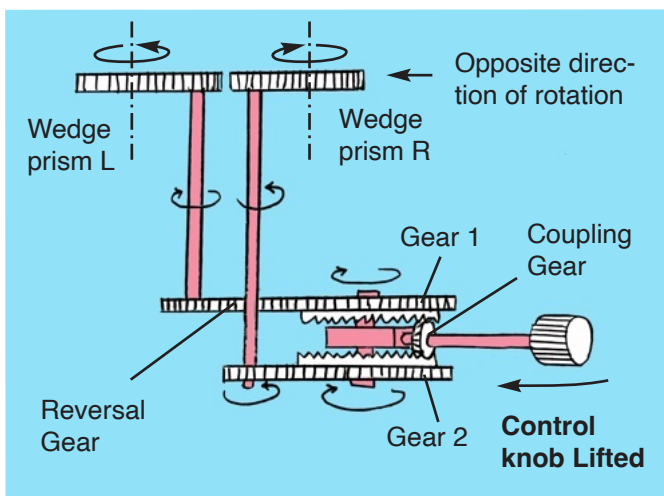
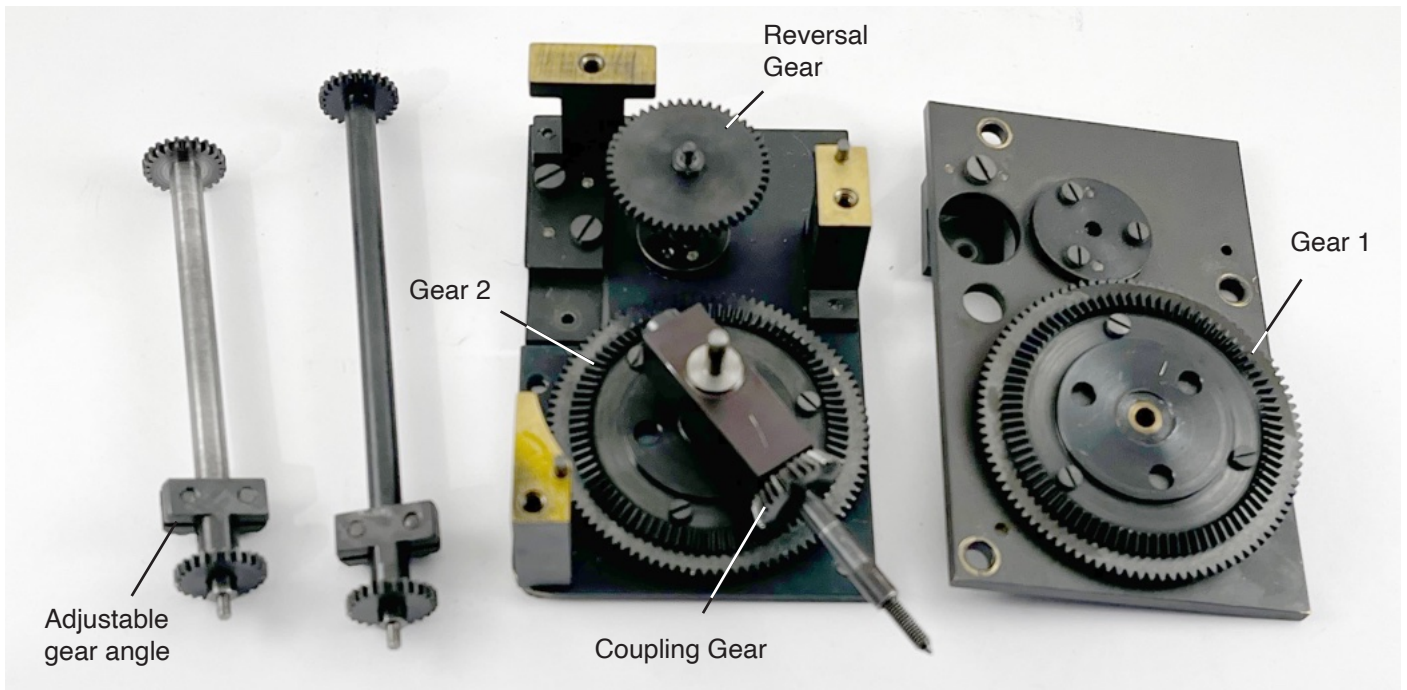

The differential gear mechanism to rotate the wedge prisms: By turning the control knob, the wedge prisms will rotate in the same direction. By lifting, or lowering it, the wedge prisms would rotate in opposite directions. Adjusting this lever to fine tune the spacing between fringes, could be a combination of turning and lifting or lowering the lever.



See Top of page 13



Fringe Control Knob; See flexure lift mechanism on page 6,16

This lever switches between the two light paths from the reference mirror, and sample. The mid position combines the two beams to get fringes. So, the intensity of each can be individually tweaked before observing the final result.



See page 15

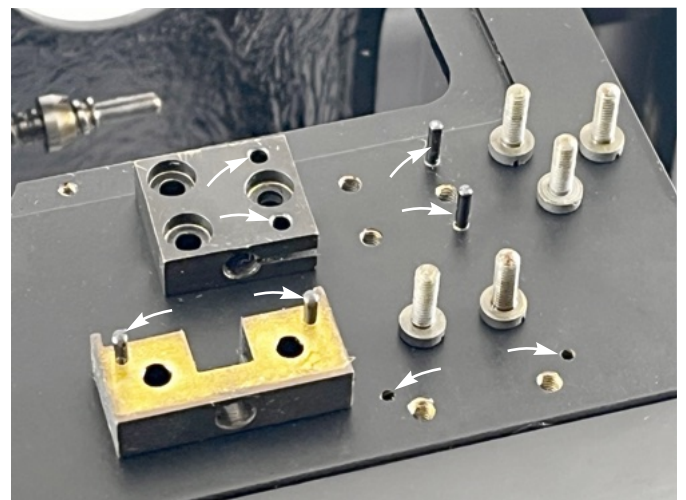

Iris setting knob (left) to adjust intensity, and depth of field, has a scale to show its position. Right, dowel pins are utilized everywhere in this instrument to insure correct alignment, and reliable fitting. This is unheard of in modern instruments.

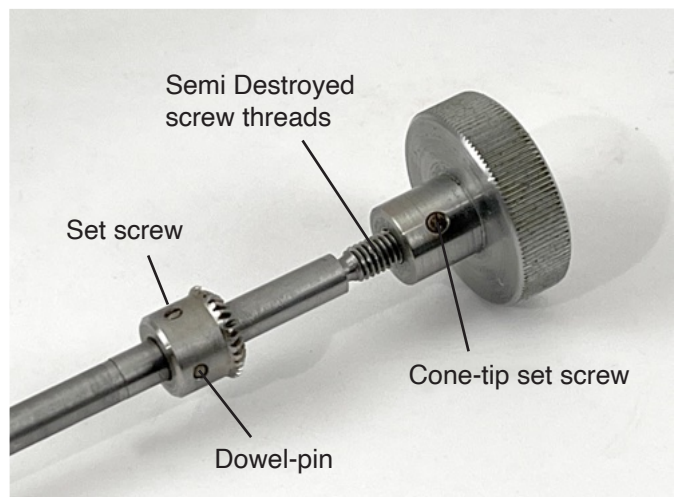
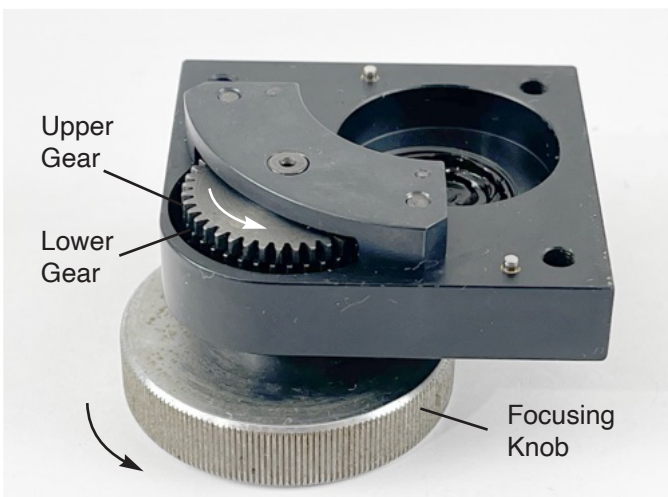

While showing the features of these knobs, one might ask: How did Zeiss secure the knobs on the shafts? In most cases, they utilized a set screw against the thread. There is a acceptable through: This is hardened steel, and the threads won't get pressed in that hard. So, you'd get the right feeling when you unscrew the knobs because no friction would be present, and no metal dust. Left, doubled up gears of focusing knob with a spring in between them eliminates backlash.

Cheap manufacturers would utilize regular hardness steel, and when you'd unscrew them, you'd encounter steel powder, and a hard to turn knob because the screw thread has been destroyed. In more critical places where there could be higher torque, they utilized dowel pins, as illustrated for the tilt knob. This knob rotates a 120 mm long shaft for top stage's tilt function (see page 19).

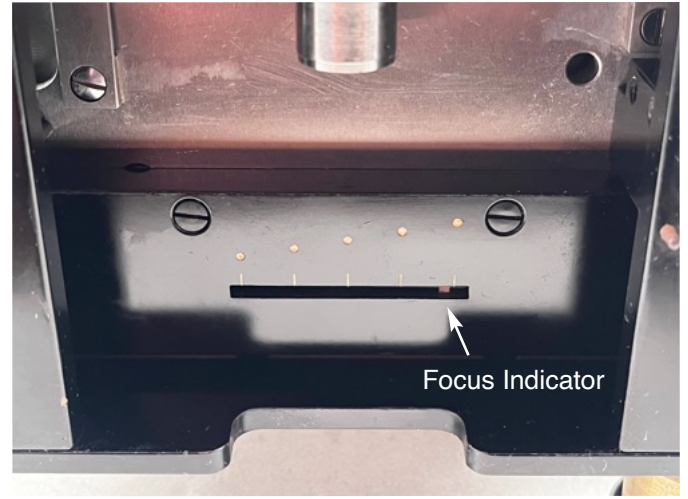

The objective turret in Zeiss Micro interferometer (left), and its focus indicator (right) has two sets of objectives. A set of three Linnik objectives, each useful for different magnifications. Intungsten light mode, it allows normal sample focusing.

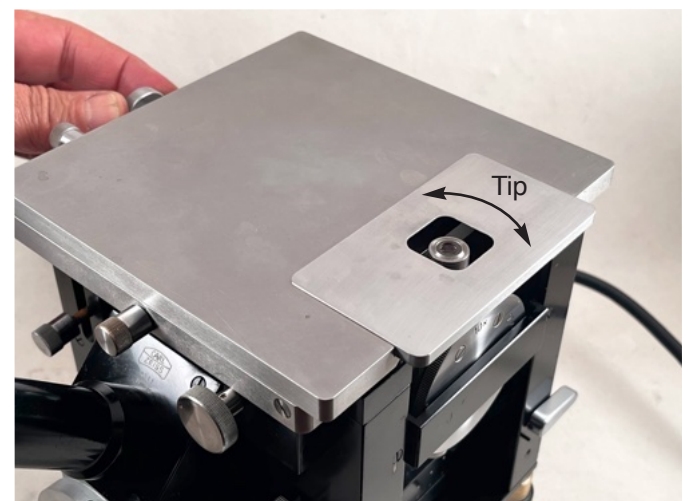
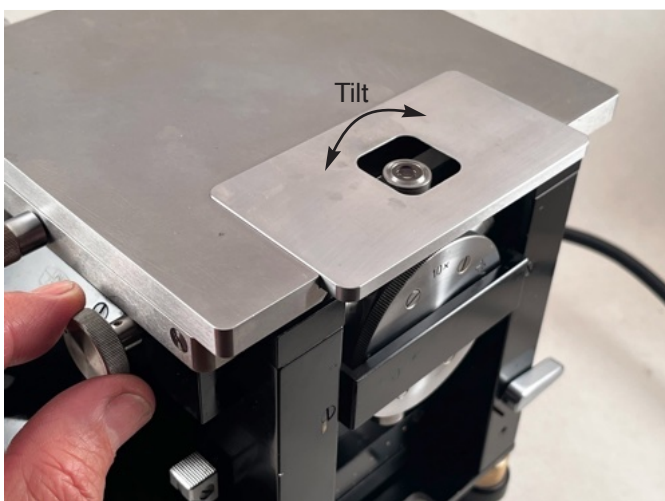

These knobs are connected to oval discs that the top stage sits on. Turning the knobs tilts the stage in the X or Y axis. For detailed view of the stage refer to page 19.

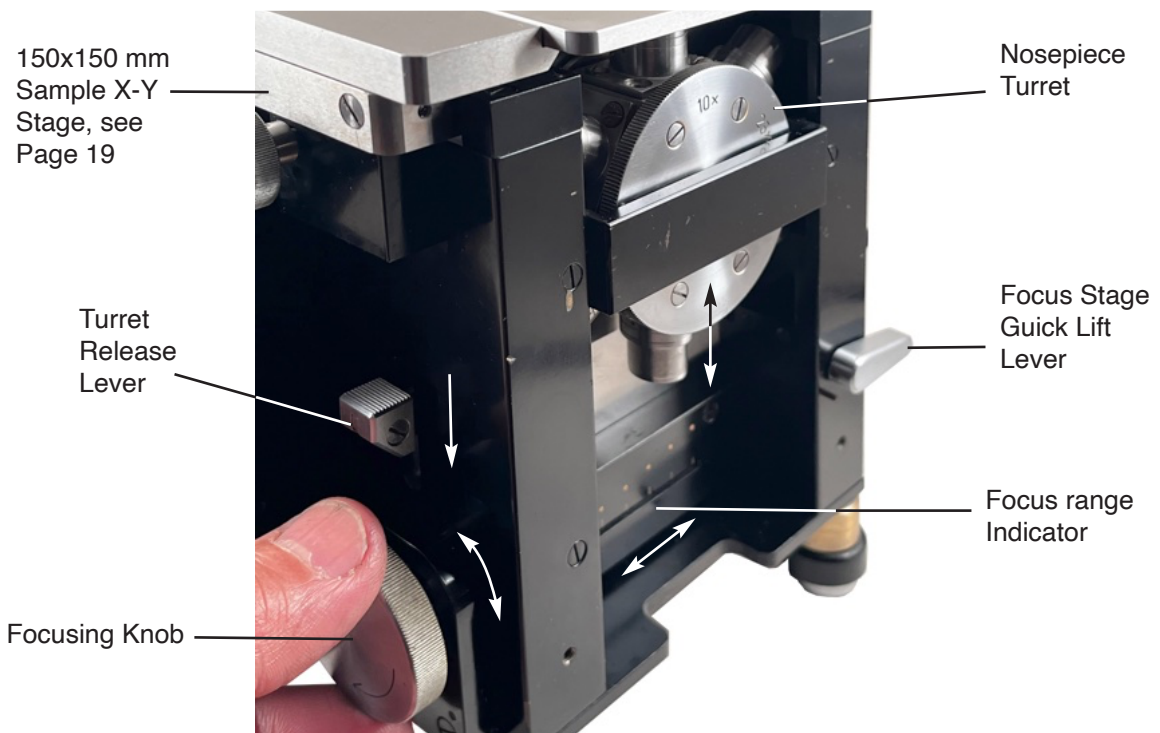

Typical setup of the interferometer on top of its wooden cabinet, with spectrum lamp power supply, and 6v power supply of its Tungsten lamp. This is not the original Zeiss power supply but works the same.

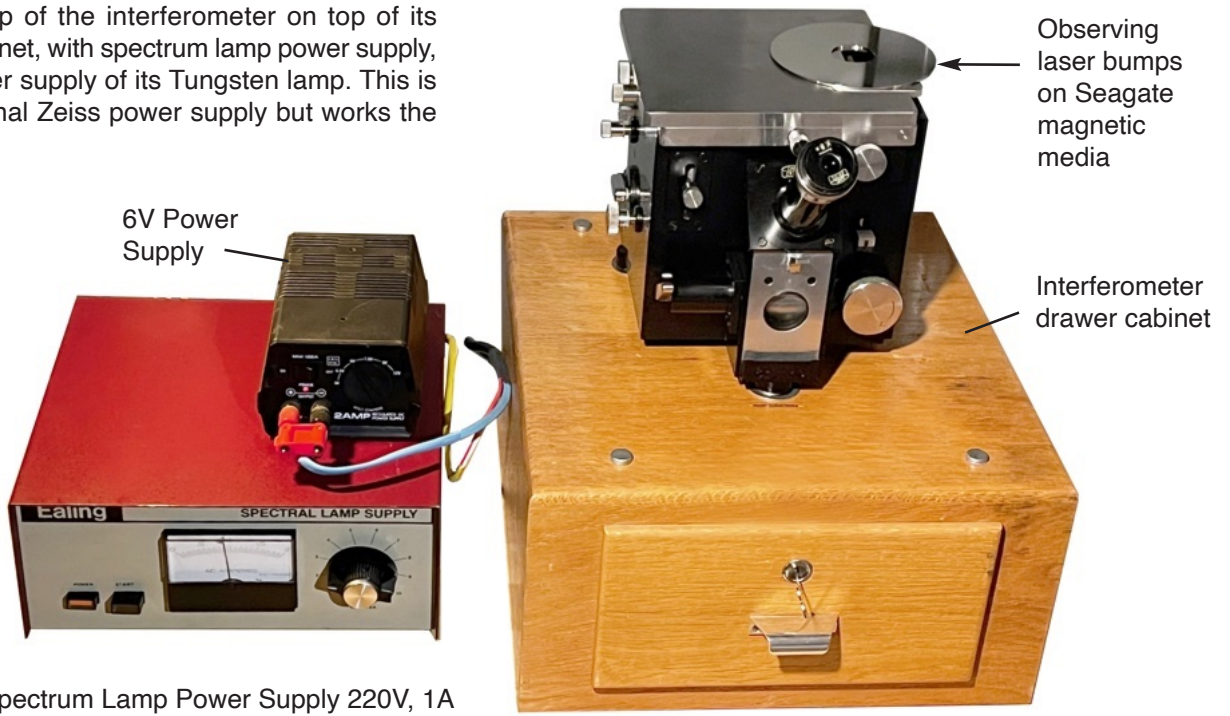

Spectrum Lamp Power Supply 220V, 1A

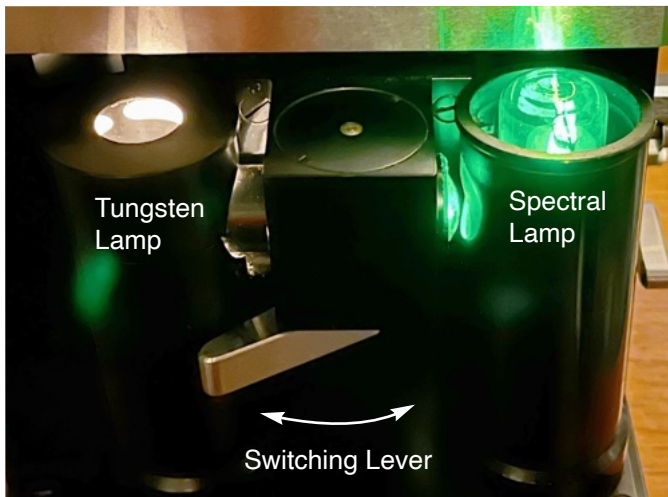

The spectral lamp, and Tungsten lamps are turned on for visual focusing to the sample, and fringe observation. The light source select lever has a mirror that rotates 90 degrees to switch the light path. Right, Osram, and 6V Tungsten lamp.

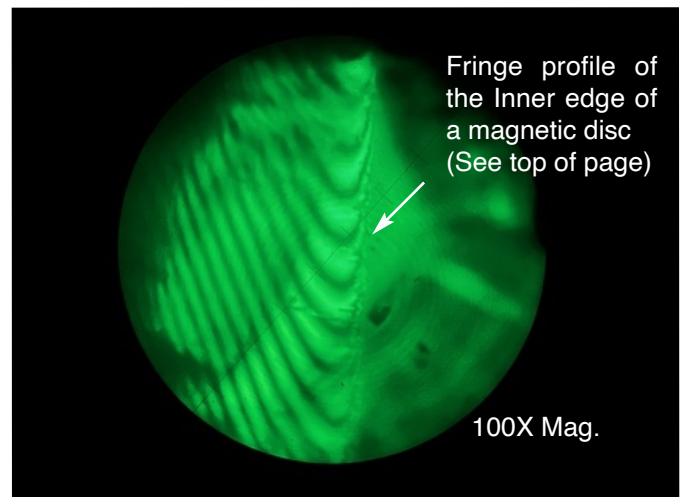
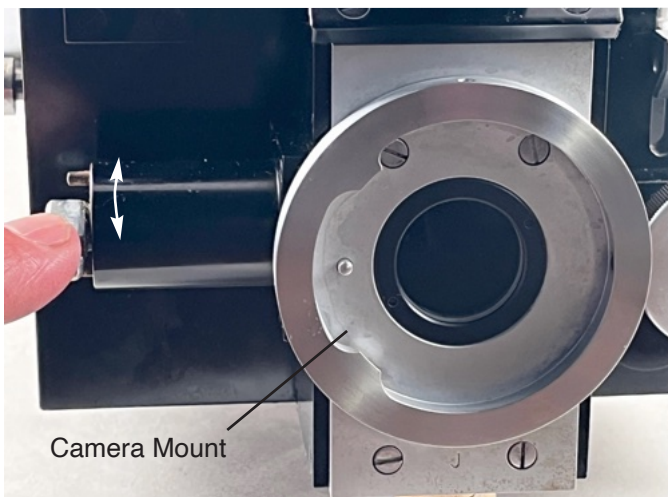

Left, a lever switches between eyepiece viewing, and camera mode. An internal mirror switches the light path, and a cylindrical shutter closes the light path to the camera window to prevent light from entering when no camera is installed.

Packing instructions	25
Introduction	3
Theoretical principles	4
The Interference Microscope	10
Manipulation of the instrument	13
Special contrivances	16
Photographic equipment	17
Interference photographs	19
Lacquer Replicas	20
Replacing the lamps	21
Special indications	22
Technical details	24
Abridged instructions	26

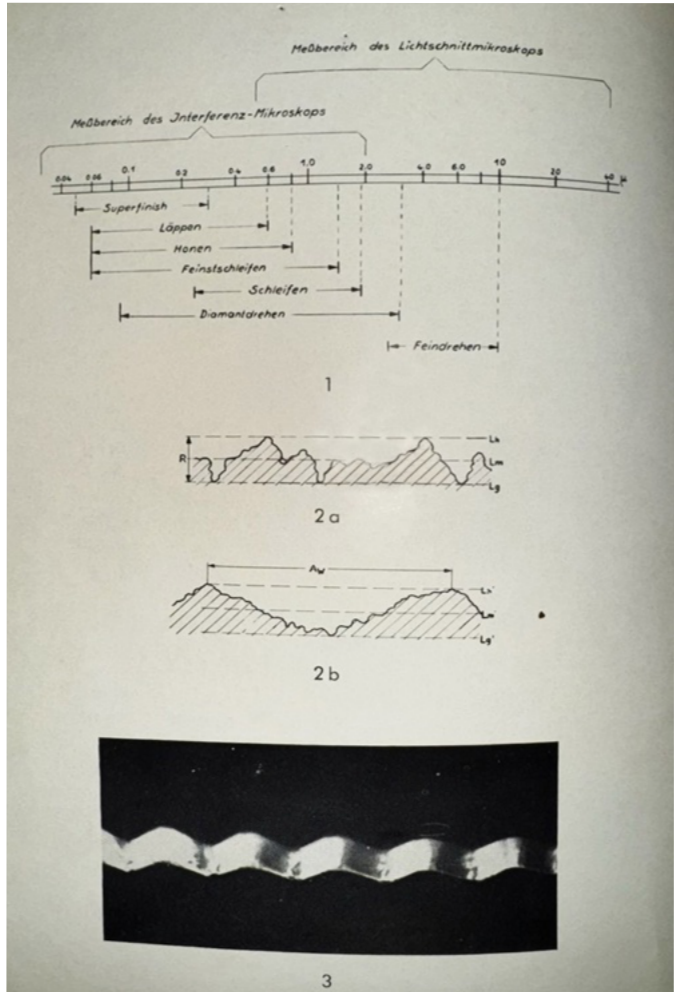
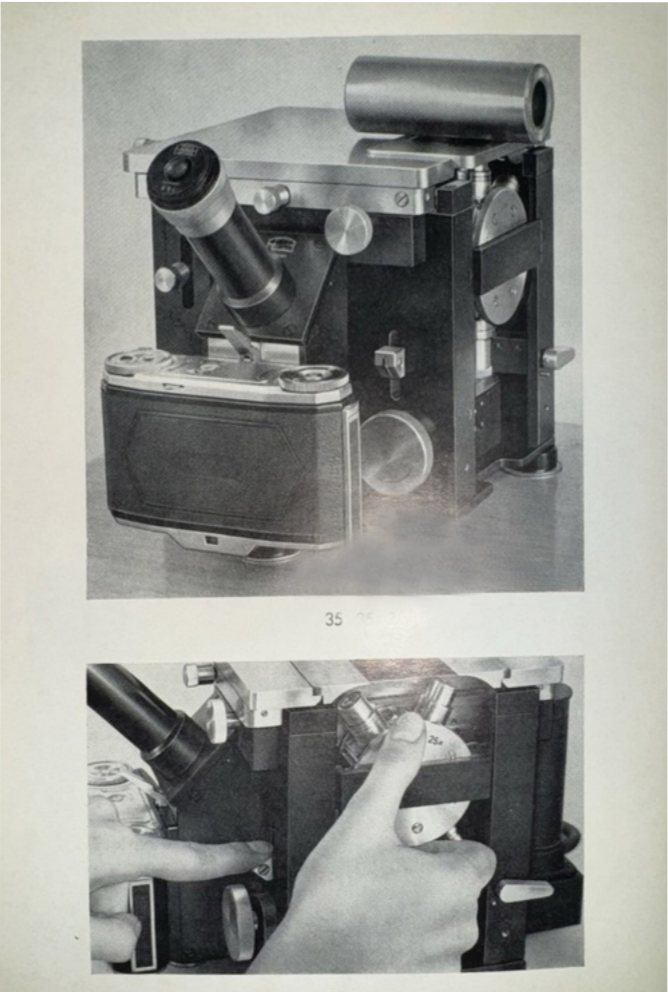
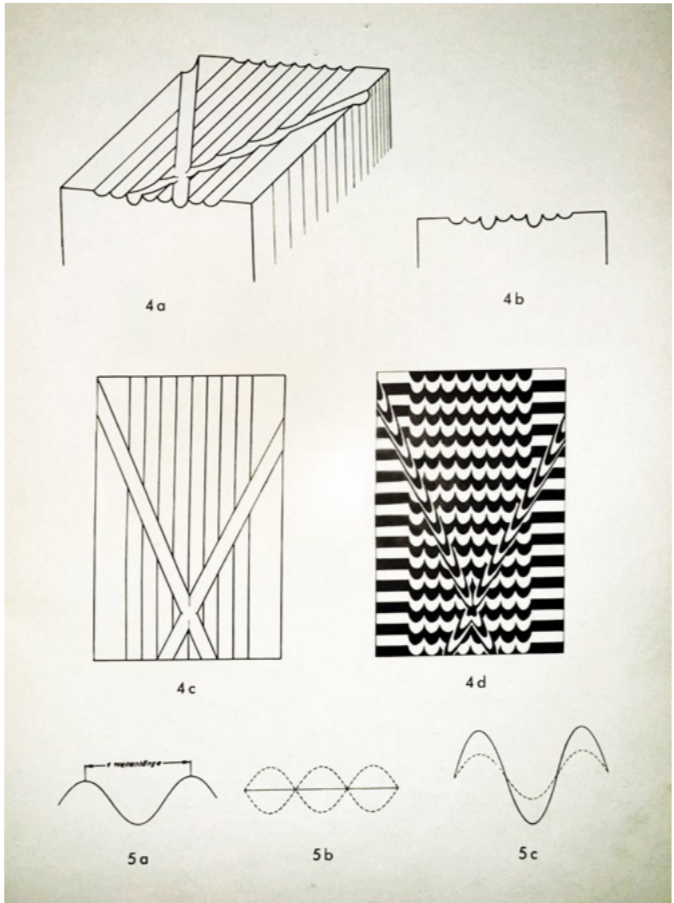

pages from the Zeiss manual shows how the fringe pattern corresponds to the actual grooves on a sample (top-right), and how to calculate the heights of microscopic terrain (bottom-right). It also illustrates how a Contax camera may be mounted to the instrument (above-left).

For all curious optomechanix enthusiasts, let's take apart this 60-year-old instrument to explore its complex inner workings. So, put your seat belt on because we'll cover a lot. The first two photos show the disassembly of the top X-Y stage which is also a tilt stage. A more detailed view of this X-Y, Tip-Tilt stage is shown on page 19, but squeezing all that into two images, here's the short explanation of how this stage is put together, and how it stays attached on top of the instrument. They decided to build this very compact, and seemingly sloppy mechanism but it's not anything less than a Zeiss.

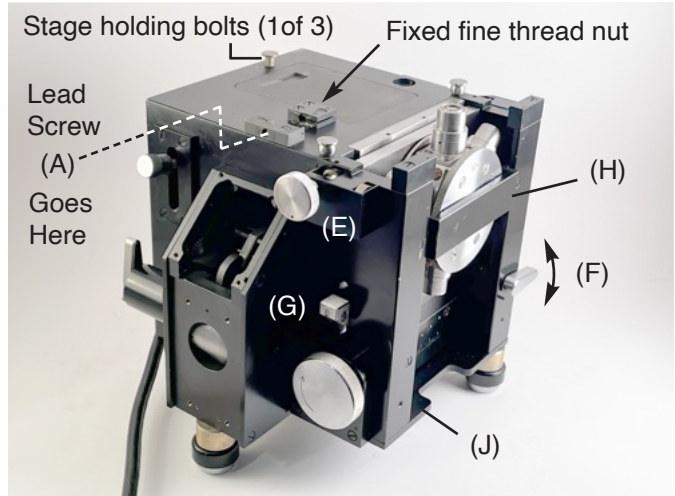
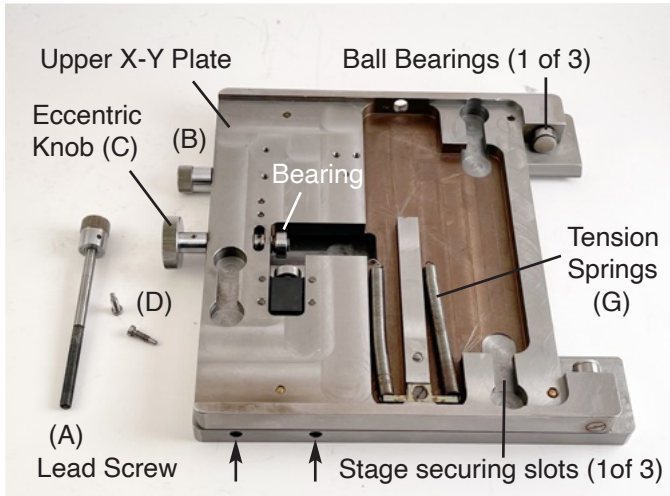

Remove these two screws (D), the lead screw (A), and unhook two tension springs (G) to take off the upper stage. The lead screws A, and B control the X-Y axis, while two eccentric knobs (C, and E) tip-tilt the top plate to control fringes. For more detailed description of the tip-tilt mechanism refer to page 16. The X-Y stage uses springs, but tip tilt uses gravity.

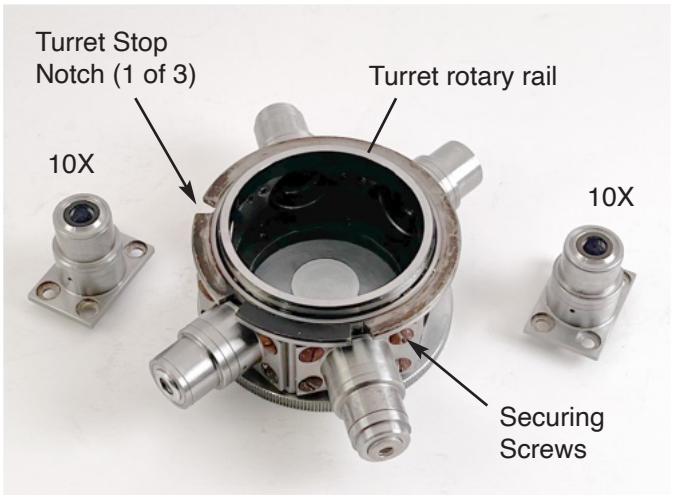

The first step is to remove the lamp assembly. Zeiss utilizes 4 screws to secure every part, unless it's a lever held by a small block (F), then only uses two screws. Even for each of microscope objectives on the turret, they utilize 4 screws.

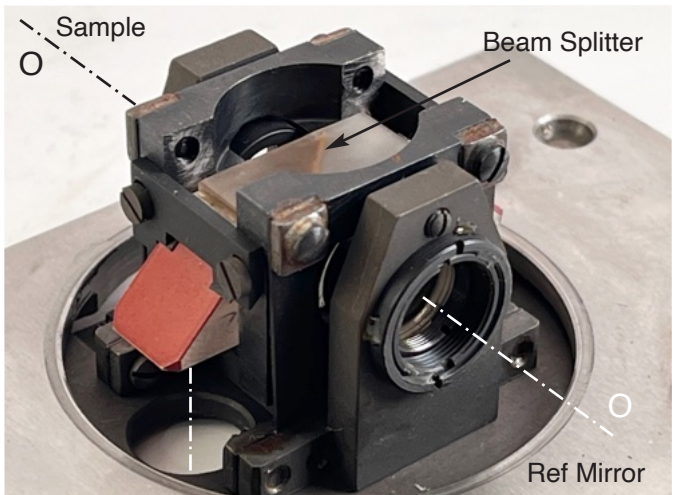
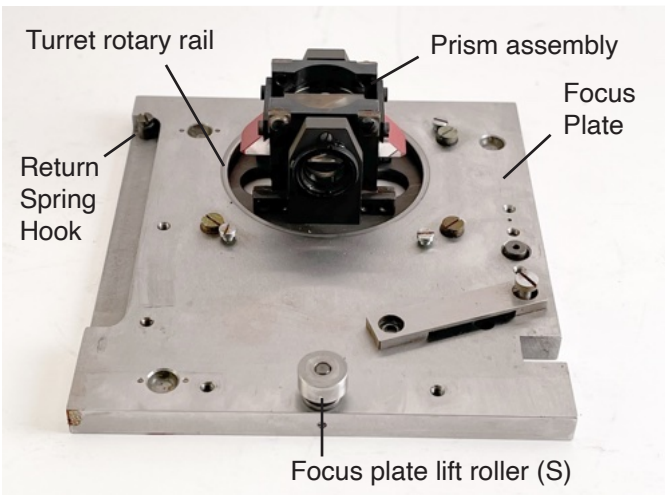

Here's the beam combining prism (right) hidden behind the turret. Lock lever (G) above, bridge plate (H), lift lever (F), and cover plate (J) must all be taken off before being able to remove this plate. This is where two beams are directed to go towards the upper, and lower objectives, then they are reflected off of the sample, and reference mirror to combine.

Focus plate steel ball V-groove guide rails (1 of 2)

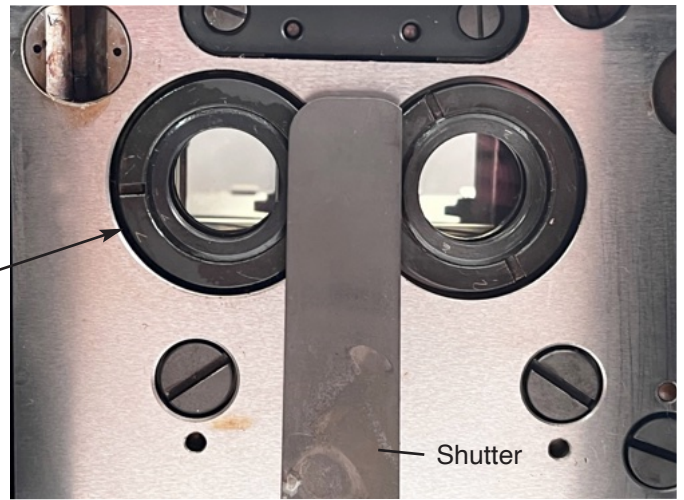
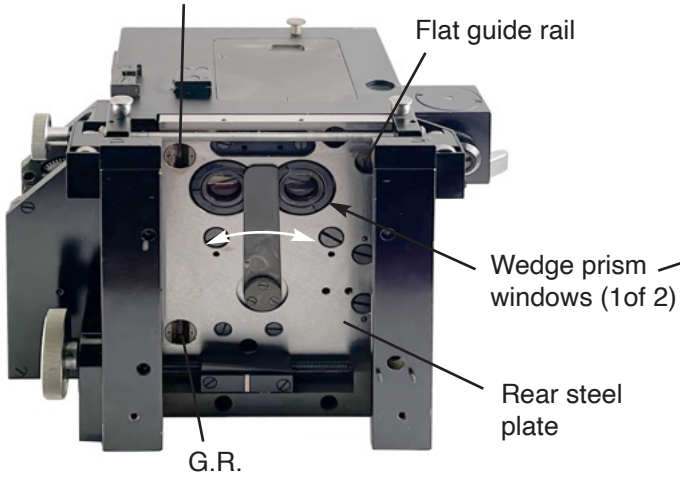

The beam path shutter switches between the two light paths from the reference mirror, and sample. So, the intensity of each can be individually tweaked before combining them to get fringes. The control lever is shown on top of page 8.

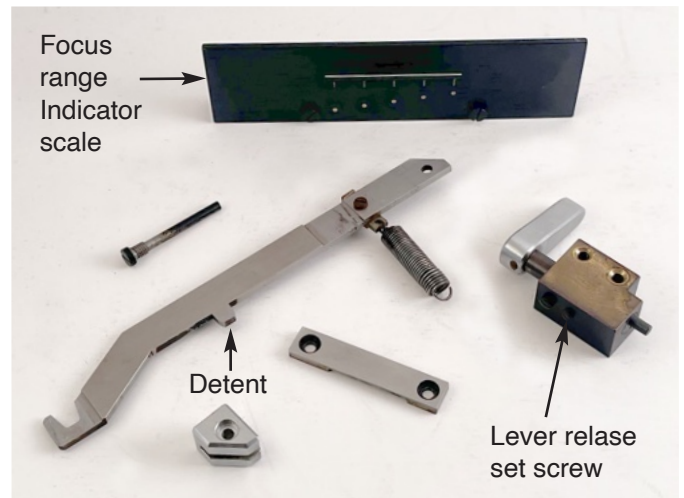
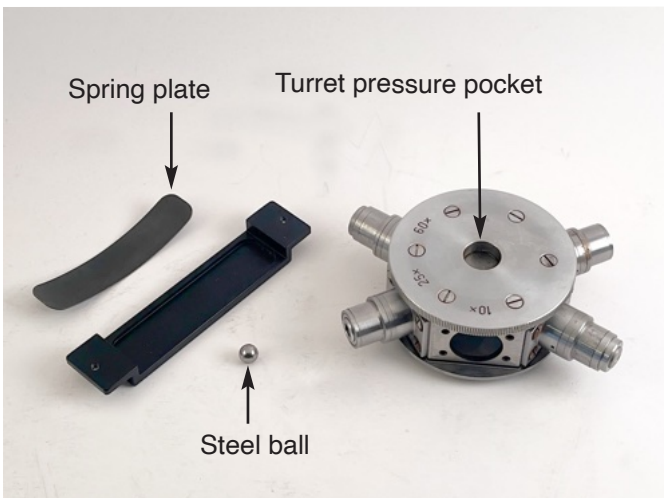

Left, the objective turret is pressed against the focusing plate by a flat spring, and a steel ball. Right, components of the turret's detent. The spring plate also pushes the focus plate against its rear fixed plate, sandwiching three steel balls.

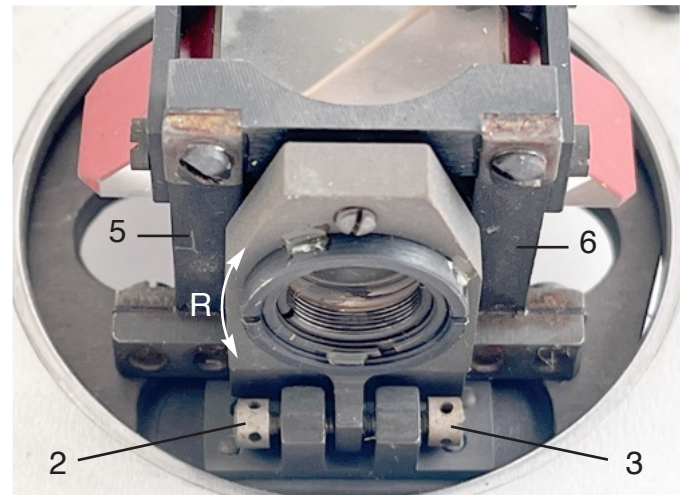
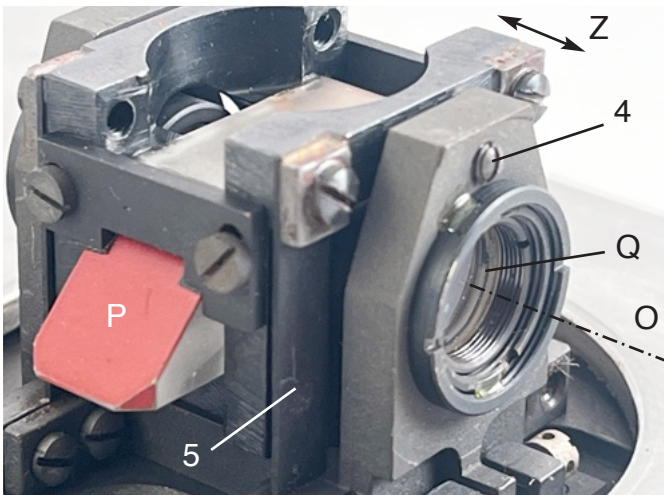

This is the most critical part of the instrument: It's a combination of rotation, and displacement adjustment. Screws 2, and 3 adjust the rotation R of half-wave plate Q. The prism P is held by a pair of flexures 5&6 on each side. Set screw 4 translates the prism in direction Z along the optical axis O. The principle in which this operates needs to be explained to those who have not worked with polarizing optics.

So many alignment points in the assembly that makes you wonder why so much attention paid to details? For example, the role of Set screw 4 on each side is to shift the prism back and forth in the Z direction, riding on flexure legs 5, and 6 on its both sides. Fine screws 2, and 3 are for precise rotation R of half-wave plate Q on both sides.

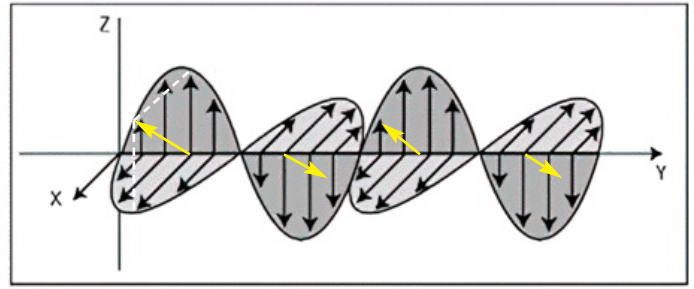
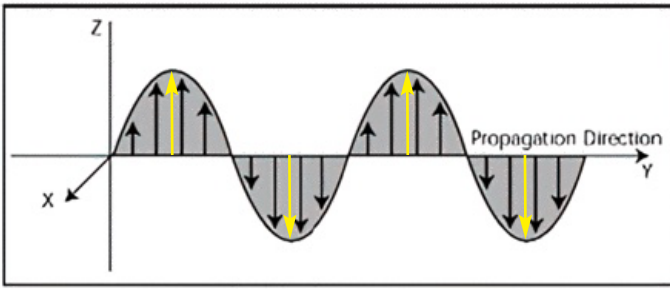

Polarized light (blue arrow) can be represented by vectors showing the direction of vibration of electro-magnetic waves. If you add every pair of vectors (right), you'll get a polarized light, but at a 45 ° angle.

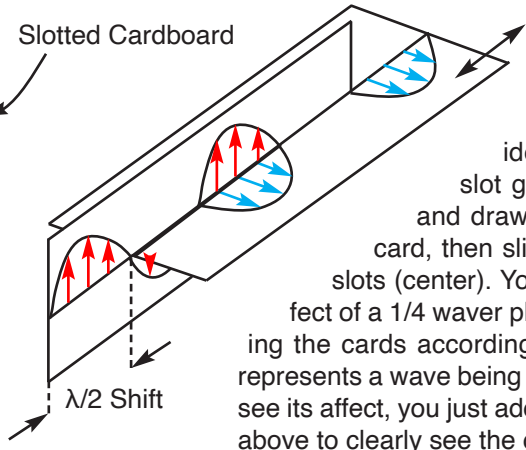
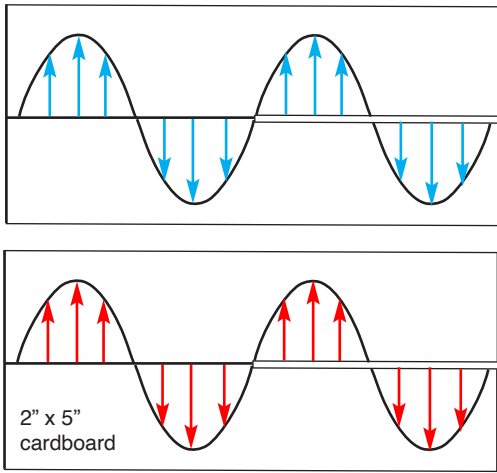

If you want to learn polarization optics, cut out two 2x5" identical cardboard pates with a slot going half way the length (left), and draw two full wavelengths on each card, then slide them together through their slots (center). You could now clearly see the effect of a 1/4 waver plate, or a 1/2 wave plate by sliding the cards accordingly. The 1/2 wave plate shown represents a wave being delayed by 1/2 λ in one axis. To see its affect, you just add the lined-up vectors as shown above to clearly see the direction of polarization.

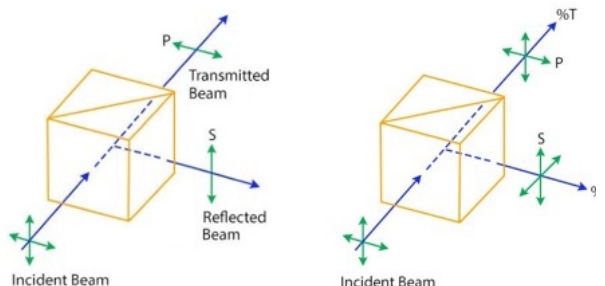
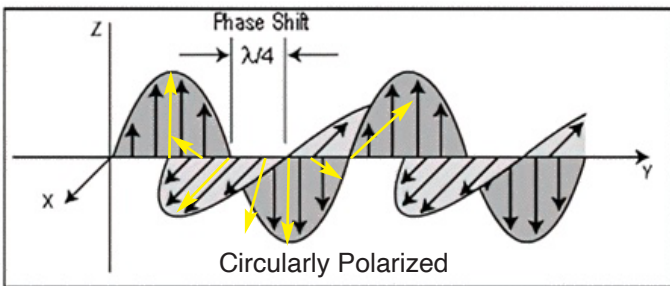

Left, a λ/4 retard plate would delay the beam in only one direction by 1/4 of a wave. This would cause a circularly polarized light (rotating vector). You could easily see this by using your physical model. Right, a polarized beamsplitter prism (middle) transmits, and reflects two orthogonal components where as a regular prism reflects non polarized beams (Right).

A few points about the interferometer:

- 1) Zeiss utilizes two wedge prisms to align the two beams. As far as I know, this is unique to this interferometer. Common interferometers utilize tilt adjustment on their fold mirrors. This design, and how the two prisms are controlled is brilliant.
- 2) Beam paths from each arm reflecting off of the ref mirror, and the sample (right), then go right back to where they came from. The interference occurs where the beam is combines for observation. This is further explained on page 18.
- 3) λ/2 plates can be utilized to rotate the polarization vector to any desired angle. To visualize this, shift the cards as shown above by a half wave, you would see the polarized beam can be rotated to any angle when it passes through the wave plate. Zeiss has set their λ/2 plate to rotate the Pol. angle by 45 degrees.

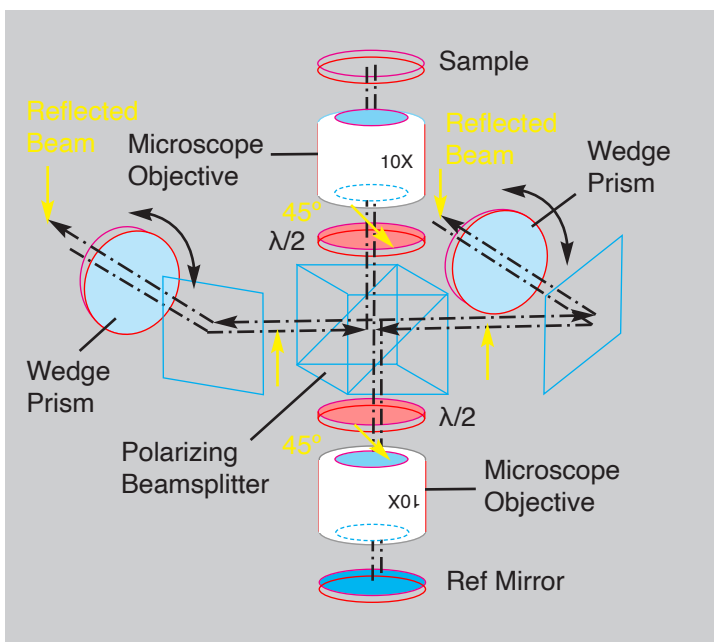

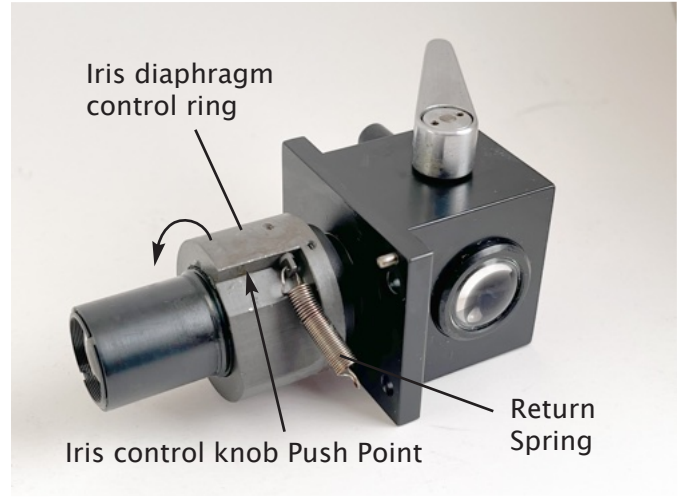
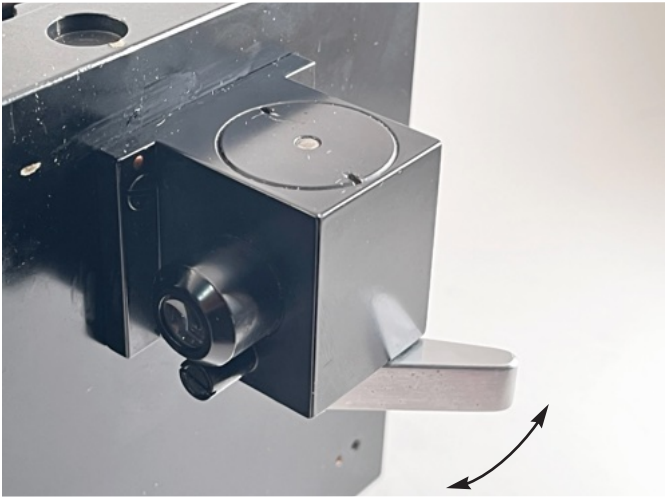

The lamp source selector lever switches between the spectral / tungsten lamps. Its mirror rotates 90 degrees, and it has positive detent stops at both ends. Right, the iris control knob pushes against this point to rotate the iris control ring.

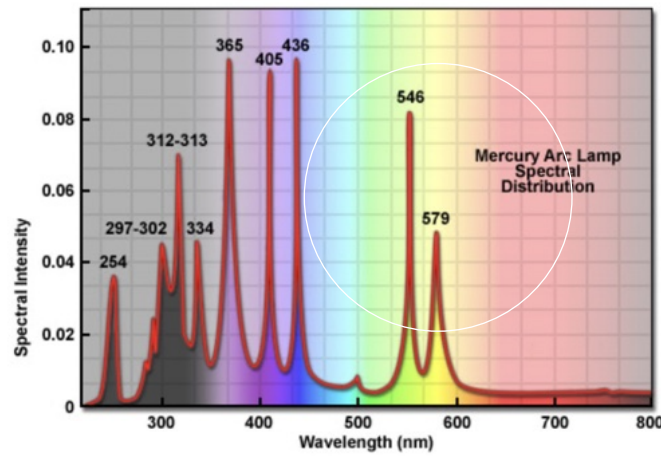

Left, components of lamp selector assembly consisting of the fold mirror, iris control ring, condensers, and collimating optics, flip mirror control lever, and detent. Right, the peak of Mercury spectral lamp 40 to 80 nm width around 546 nm.

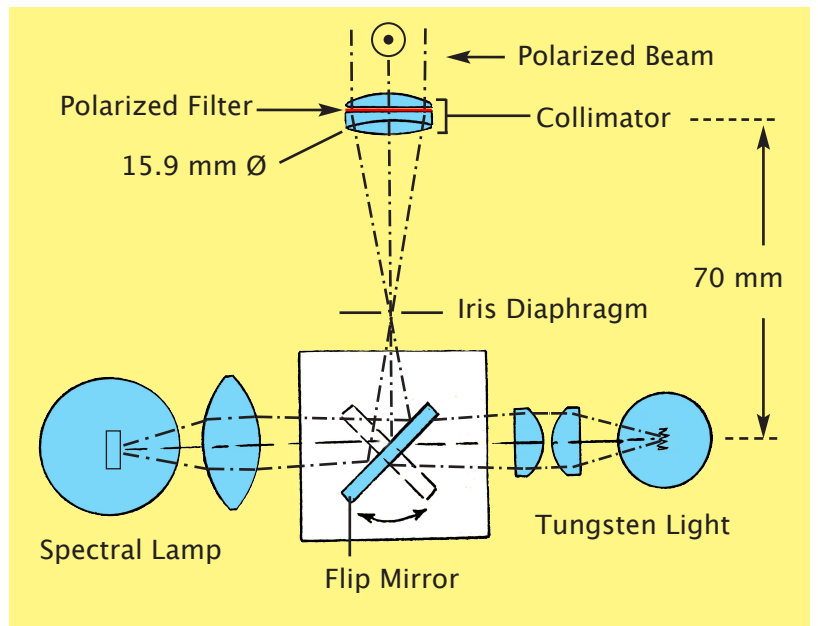

The Osram spectrum lamp type Hg (Mercury) utilized in Zeiss (left) gives off a monochromatic beam of light in the green region with bandwidth around 40 to 80 nm centered at 546 nm. The 230V power supply is set to 1.2 Amps (see P 10).

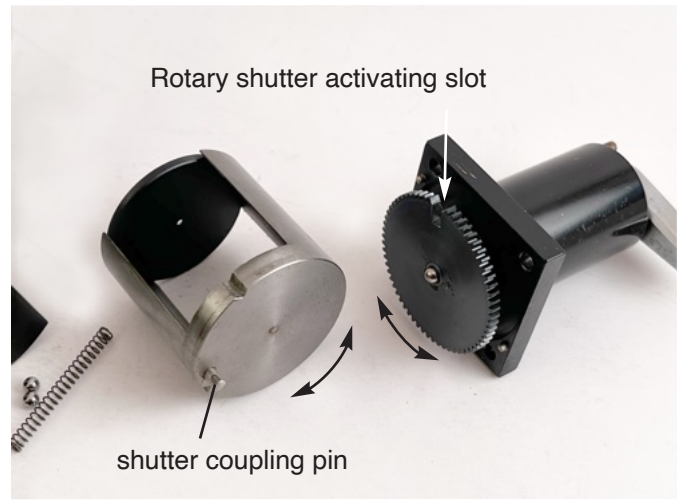
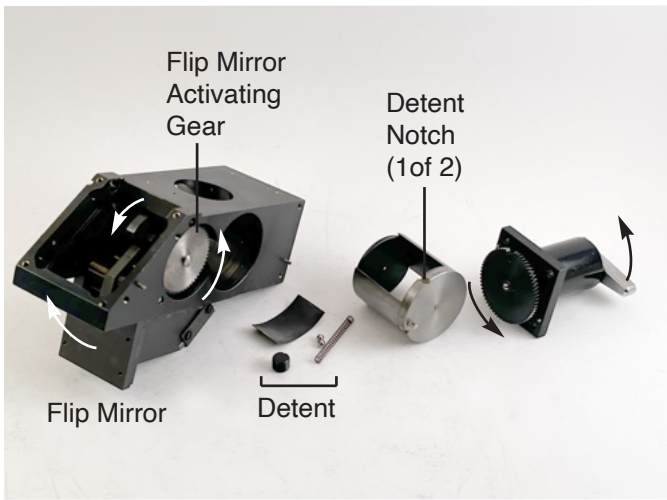

The beam path lever switches between the two light paths between the eye, and camera. There is a rotary shutter that blocks the light path when there is no camera installed. A gear timing should be observed during reassembly.

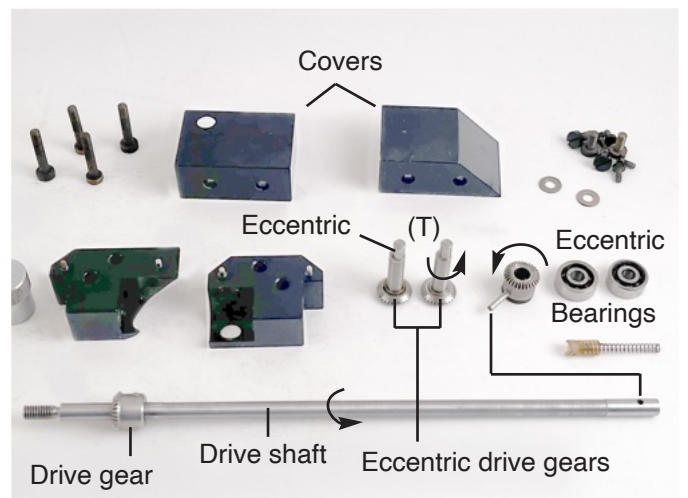
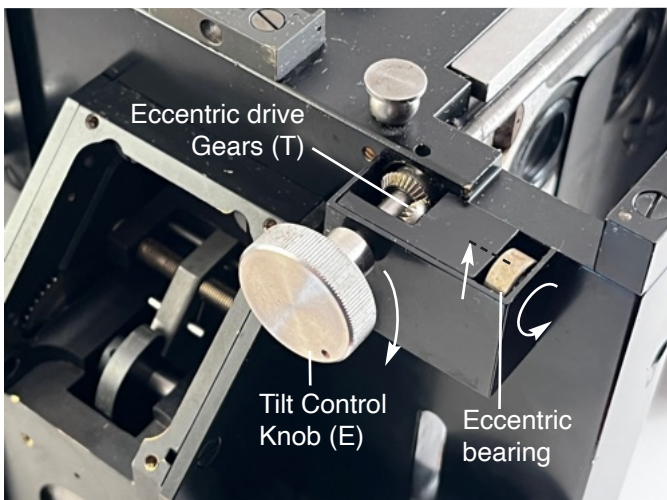

This is a more detailed explanation of how the tip-tilt knobs that were shown earlier on top of page 12 actually work. The tilt knob drives two bevel gears on opposite ends of its drive shaft. The gears drive two eccentric shafts (T) that cause the two bearings placed 120 mm apart to move up and down in opposite synch, causing a tilt on the top plate. Go to page 19 to see the entire top plate assembly.

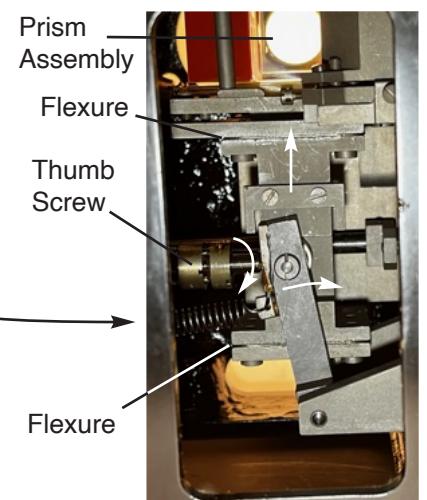
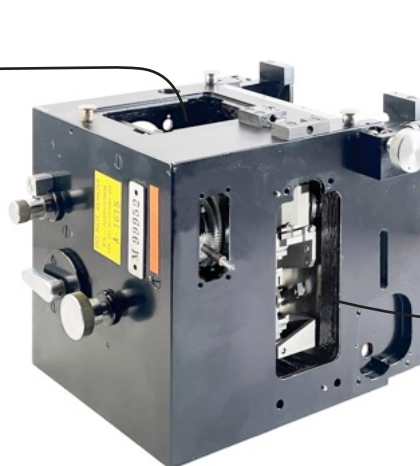
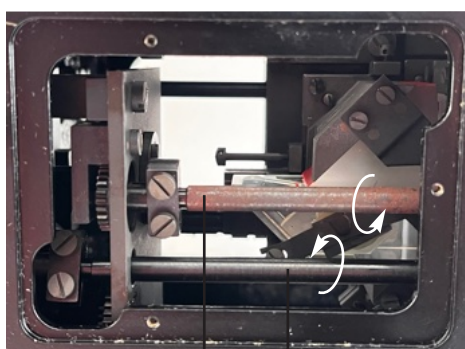

Access points of inner mechanism with body covers removed

At this level of disassembly, we could see the beamsplitter drive shafts (above), and Flexure assembly, and its drive pin (right). When the frontal steel plate is pulled off, some control knobs remain on the back plane of the diecast housing. The tilt control shaft, and focus dive shaft have to be first removed. I hope after my disassembly images, university level institutions will become more interested in studying this instrument, and more papers will be published describing its unique design.

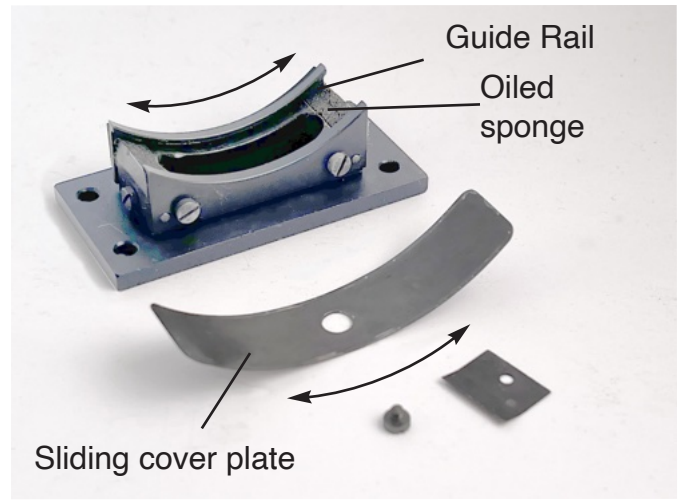
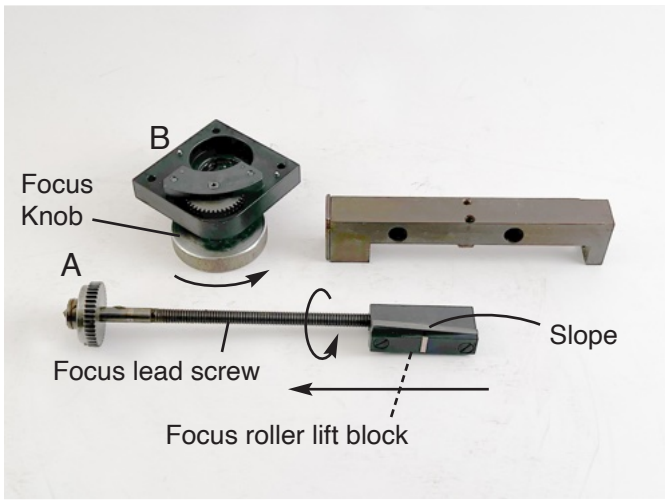

The focusing mechanism lead screw translates focus lift roller (Q) shown at bottom of p12. There are two pins attached to gears A, and B (also shown on P8). With an exact number of turns these two pins will collide to stop the focusing knob from turning. Right, the differential gear sliding cover plate is designed to protect the inner gears from external dust.

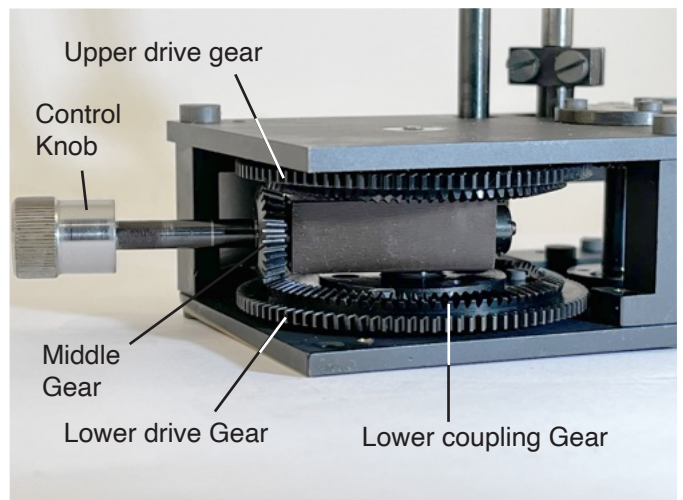
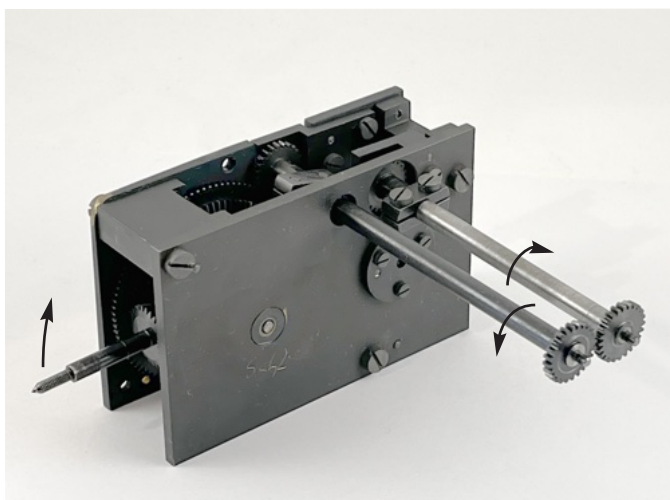

The differential drive gear simultaneously controls the rotation of two wedge prisms. Pushing this lever up and down rotates the wedge prisms in the same direction. Turning this lever rotates the wedge prisms in opposite direction.

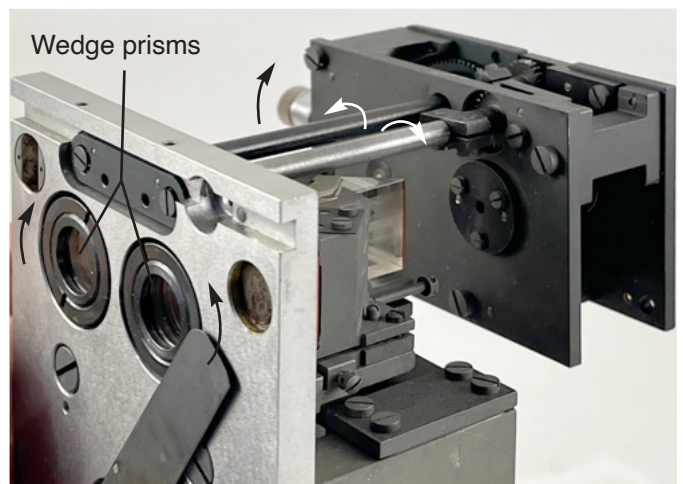
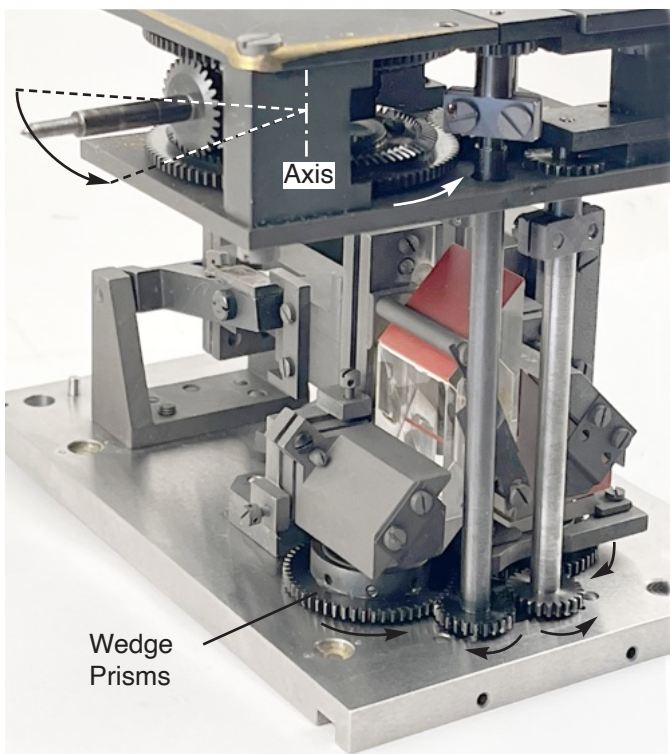

Above, pulling down the control lever causes the middle gear to rotate both upper, and lower gears whereas rotating it would cause one gear to rotate in opposite direction to the other. Zeiss is able to utilize this mechanism to overlap the beams through the wedge prisms, separate them, move one up with respect to the other, or any fine alignments necessary to get fringes in its interferometer.

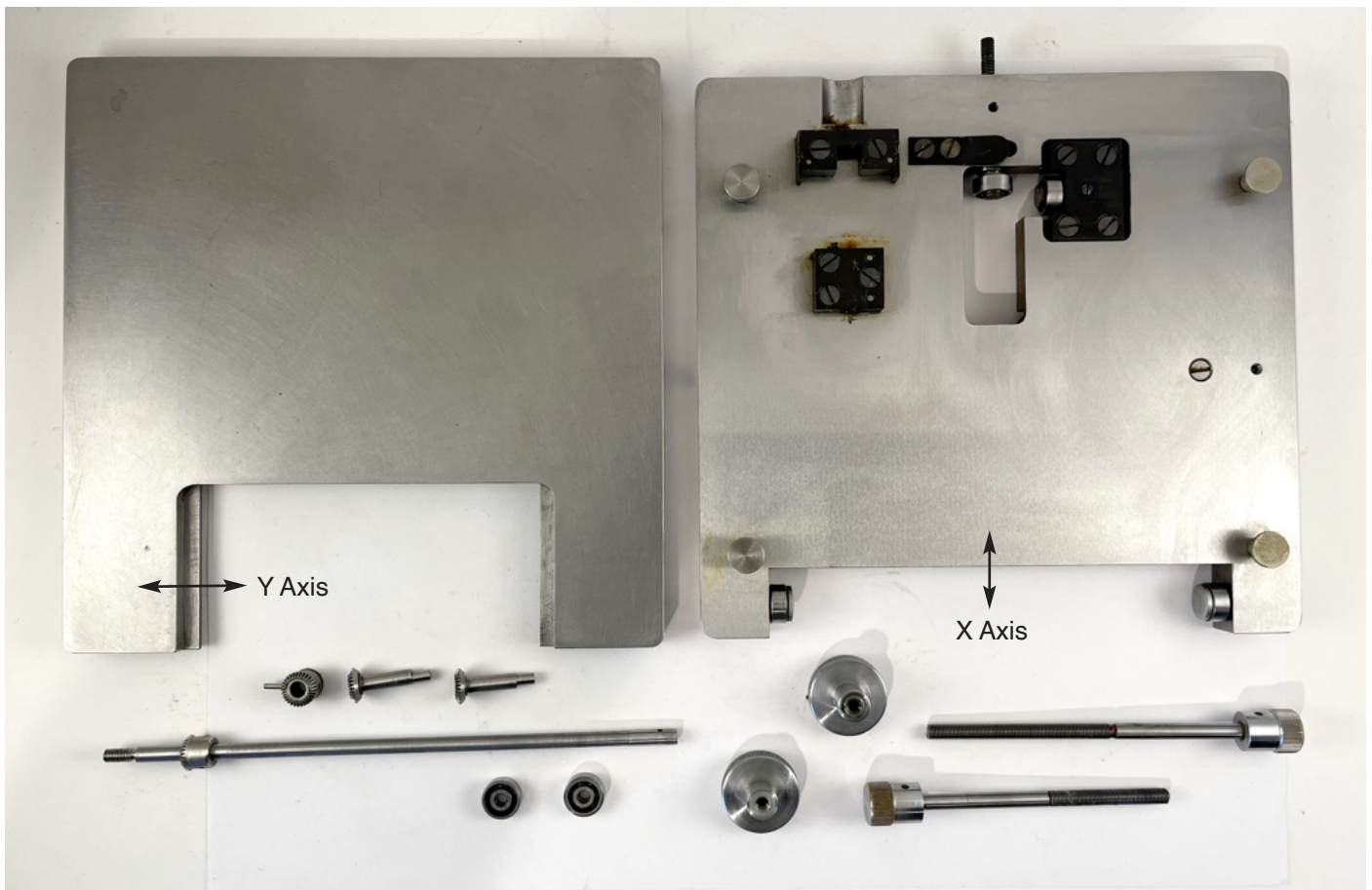
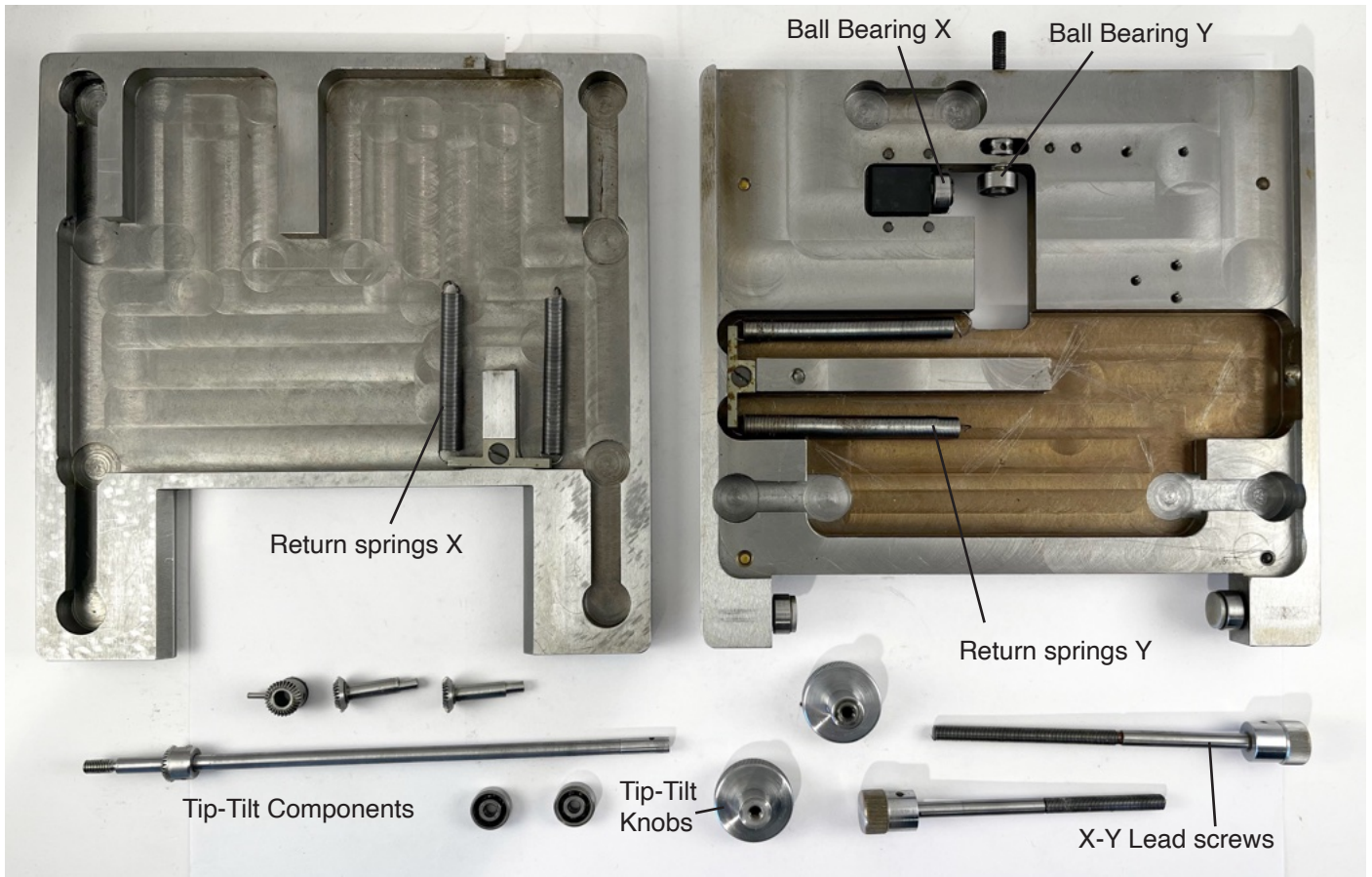

X-Y axis, and Tip-Tilt combination in Zeiss interferometer is extremely compact, and reasonably accurate for their interferometer. Many people, I'm sure will not be able to take this off easily. It tends to be more of a surgical instrument rather than a design from their microscopy branch.

GOTO Optical Projection Planetarium

Planetariums are much like reversed pinhole cameras. Instead of imaging the outside world on film, it projects the small filament of a tungsten or Xenon light bulb at a spherical dome outside of its black box. As you could see from below, the challenge is the planetary, and star projection are not colinear. Coupling gears are needed to rotate both the star projector, and the planetary projector simultaneously.

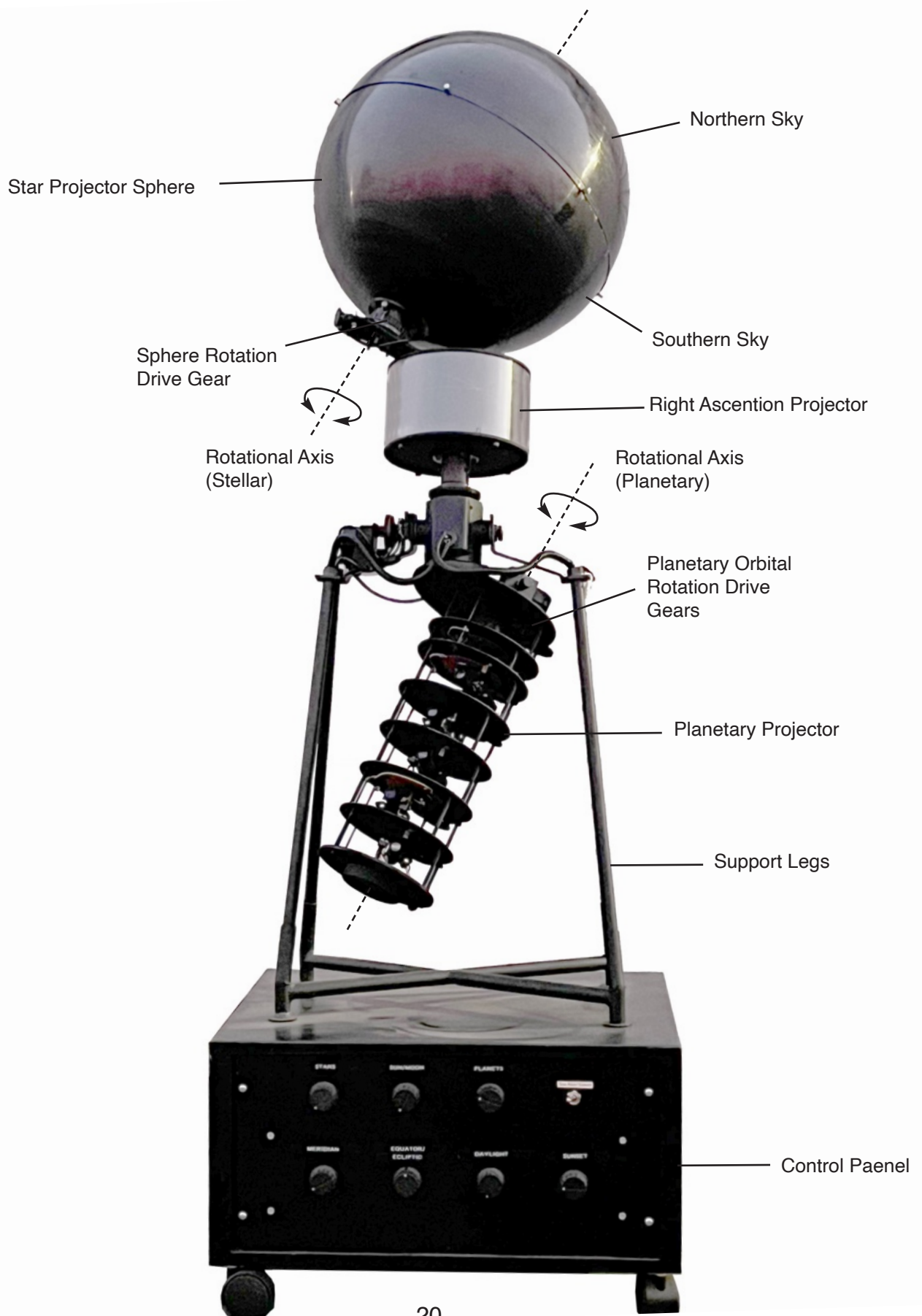

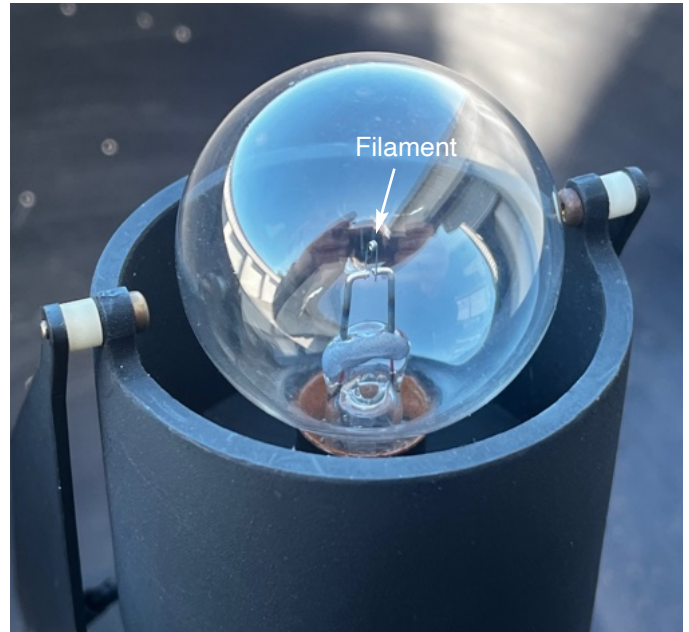
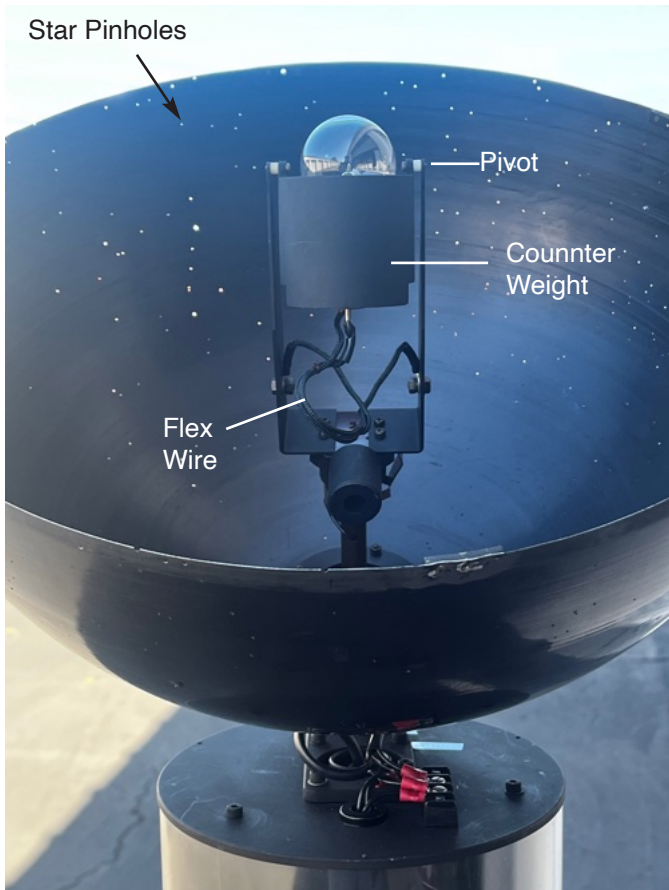

The specially made small filament tungsten light source in a planetarium is weighted on its bottom to always look up. While in the dark, the planetarium may be rotated upside down. The lamp would rotate accordingly to illuminate the pinholes that are facing towards the projection dome above.

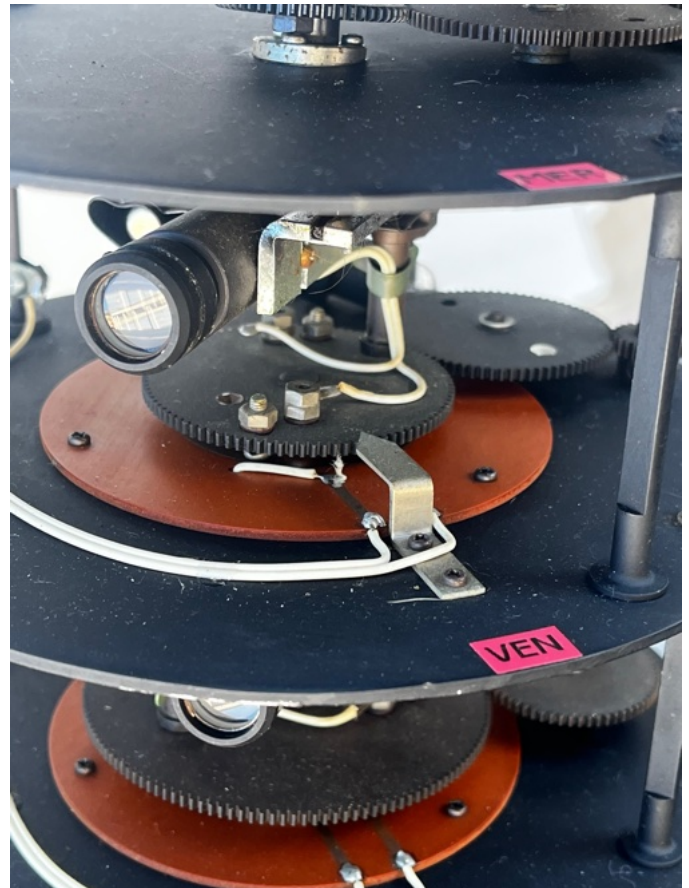

The planetary projection is achieved by projection tubes that carry still images of planets, i.e., Venus, Mars, Saturn, Jupiter, etc. Each of these projectors rotate 360 degrees via a complex gear train that sets the rotational displacement of each planet along its axis. Everything in the Goto projector must be created optically with separate illumination sources. There are 15 individual light bulbs inside the Goto projector.

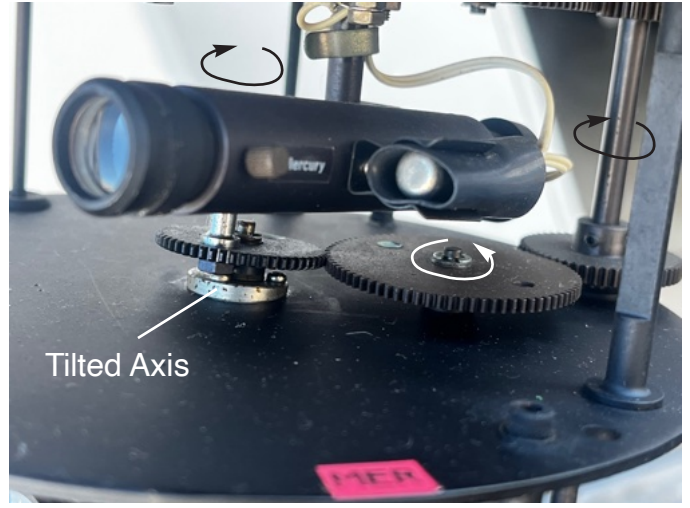

Right, the tilted Mercury orbit drive gear rotates back and forth because it is in the inner planets of the solar system. Mercury's movement as it moves across the sky is the most noticeable object in the planetarium.



The electrical wiring of planetariums are challenging because it should be able to rotate 360 degrees on each axis. Some contacts like the central filament are powered by a brush + conductive disk method, similar to electric motor armatures.



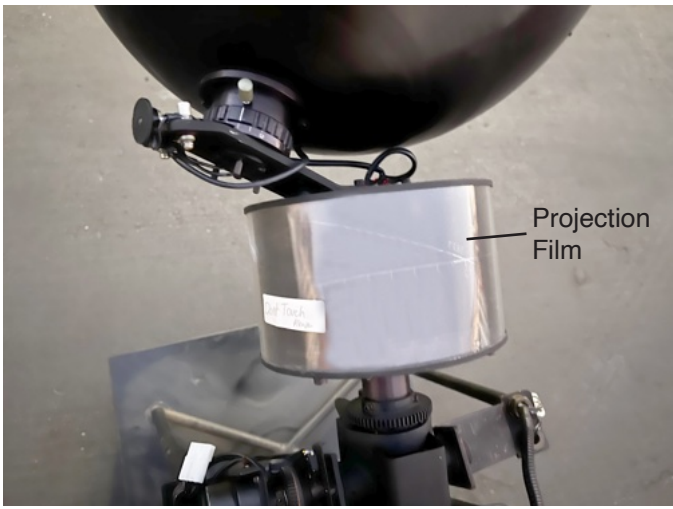

The 360-degree graduated meridian projector tells the angular position of stars on the right ascension axis. There is also a graduated declination projector (bottom of page).



More detail of the graduated Meridian line projection cylinder (left), and labeled planetary discs from bottom to top: Saturn, Jupiter, Mars, Earth, and Venus.



The control panel sets the speed, lamp intensity, sun-set, etc.



Graduated declination projector

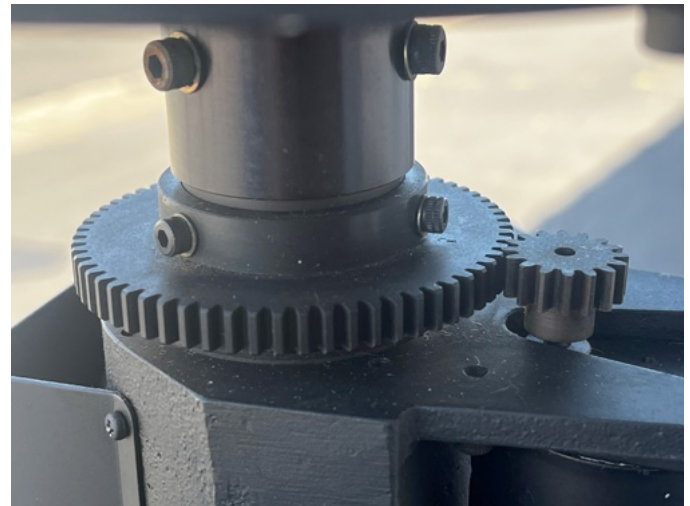

Above left, the main servo drive motor, and the star projector coupling gear (right). There is also a milky way projector that projects the milky way as a fuzzy cloud across the sky (dome).



More details of the planetary, and lunar phase control gear train show the rotating control shaft, and how it drives the rotation of each planet across the sky. Watching Mercury is the most noticeable object in planetarium skies: Because it is in an inner orbit around the sun, it travels back, and forth instead of a continuous passage across the sky.

Digital Planetarium

My friend Kieth Miller built this wall display planetarium at the natural history museum, here in Fremont, California. Kieth is a true scientist, and devotes his entire time to public service, and maintaining planetariums at many museums in state of California. He also provided me with the plans to build a full dome planetarium in Iran that I am going to discuss next.

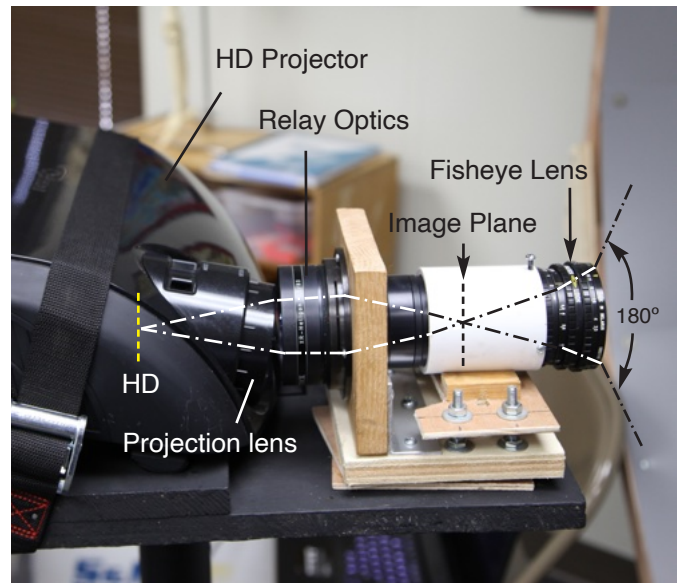

Right, most compact video projectors are designed to be put at table height, and their lens is shifted to project the image on the screen at a distance above. This is why Kieth tilts the projector downward to direct its image to the relay lens.

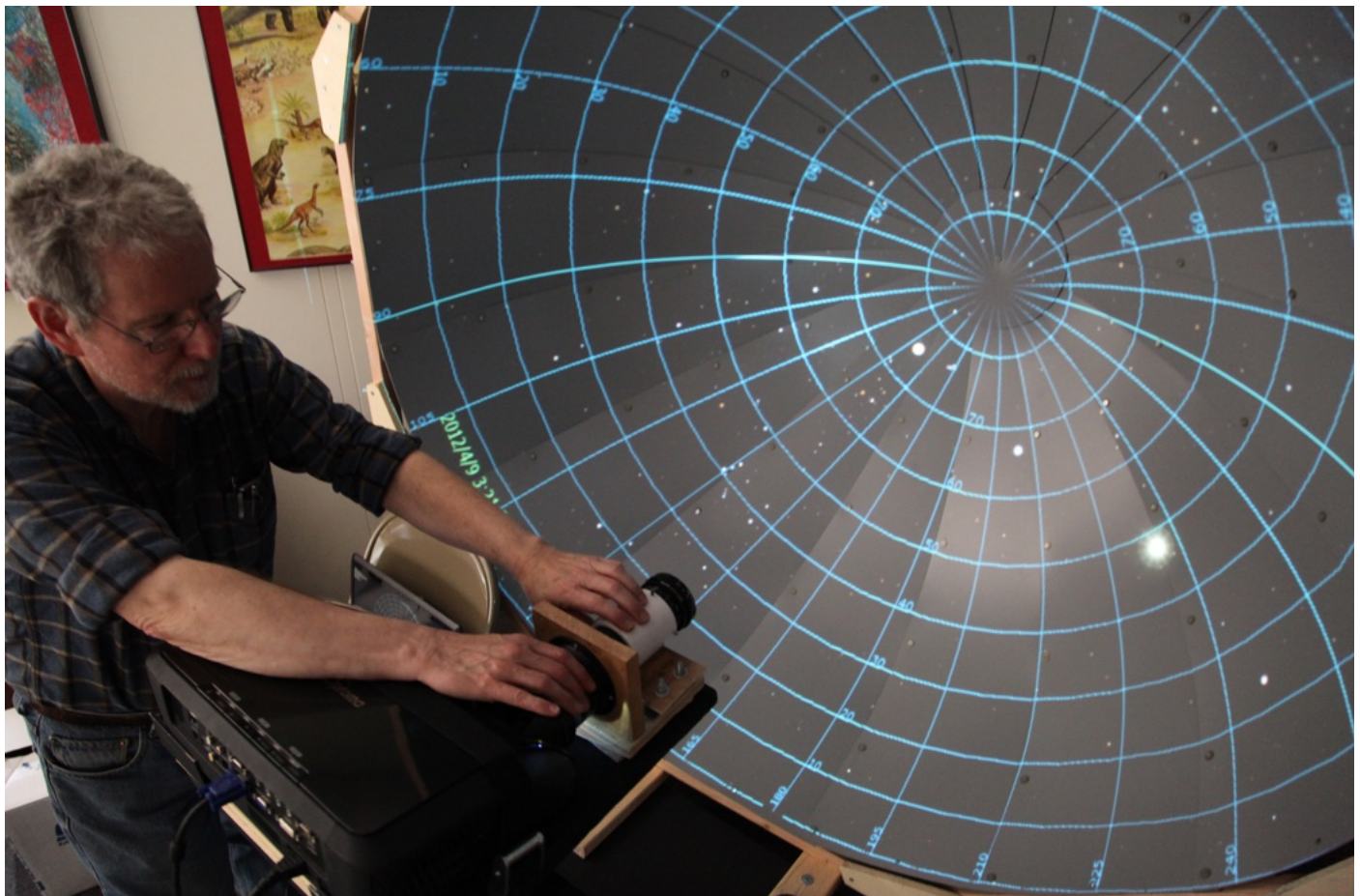

The relay optics is a reversed 75 mm f/2.8 Schneider lens (above, right), while the fisheye lens is a compact 8 mm f/3.5 lens. With the aid of the relay lens, the image is focused at its focal plane, and it is then projected onto the screen via the fish eye lens.

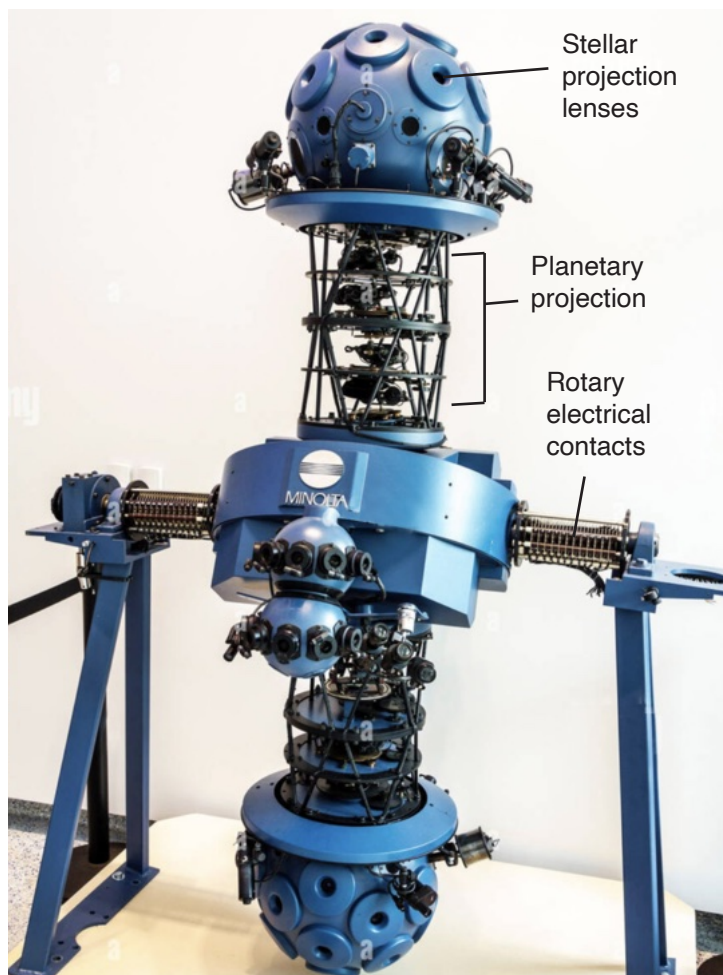

Opposite to a mechanical planetarium that had to run everything mechanically (right), a digital planetarium can project anything from stars to galaxies, or educational movies without much effort. But the dome itself is a challenge to build. Kieth has converted the ceiling of one of the rooms in their 2-bedroom apartment into a planetarium. It is an attraction to children who'd bring their sleeping bags to stay over, so they could enjoy the show till they go to sleep. Right, a full-size Minolta planetarium with two 100 Lb. diecast projection spheres, and many sub projectors for planetary, galaxy, and nebula images. New digital planetariums have replaced these intricate opto-mechanical clockwork machines. When entering a planetarium before, the projector itself was a spectacular opto-mechanical instrument to watch.

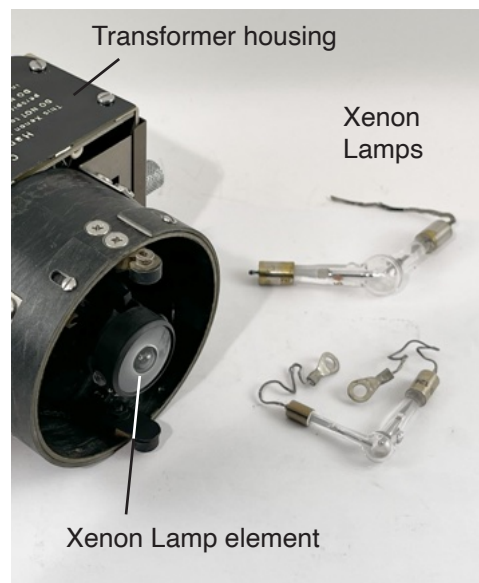

Left, inside the dome of Minolta planetarium with a 1000W Tungsten light bulb surrounded by numerous condensers to project individual slides to fill the entire spherical dome. There are around 28 discs with a few thousand drilled holes to project images of each and every star. How they would align the orientation of each disc blows my mind. Right, specially made Xenon lamps with a 90-degree bend utilized in some planetariums instead of a tungsten lamp for a larger screen projection than the Goto system.

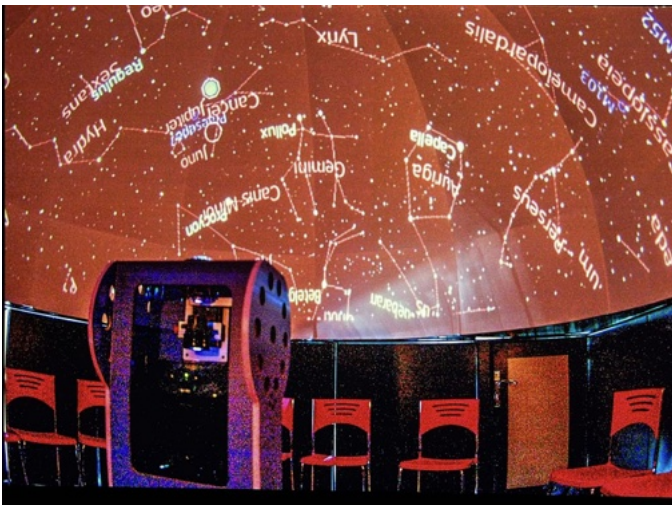

This 12 ft planetarium was designed, and built for the time museum in Tehran. The spherical dome was built with MDF panels installed inside a skeleton of 12 curved rods, standing 4 ft from the ground at its base. We had to be careful not to drill any holes on the original historic walls, and ceiling. So a cantilever was devised to support the center of dome from an existing hook originally intended for chandeliers. The plans for dome panels were sent to me by Kieth Miller.



Each panel was individually calculated, and cut, then bolted to the 12-section support skeleton. The panels overlapped, then covered with plaster, and sanded to get the final smooth finish. The projection surface didn't have to be ultra-smooth, and even 1/4" overlapped panels are hard to notice in the dark. Some users even use white umbrellas for the projection screen, but nothing matches the clarity of a professionally made screen.



All this work was worth the effort because to get the true sense of the projection space this is really necessary, and there is no other way around it. A 4ft tall entry door, and exit door was installed for children to get in, and out.

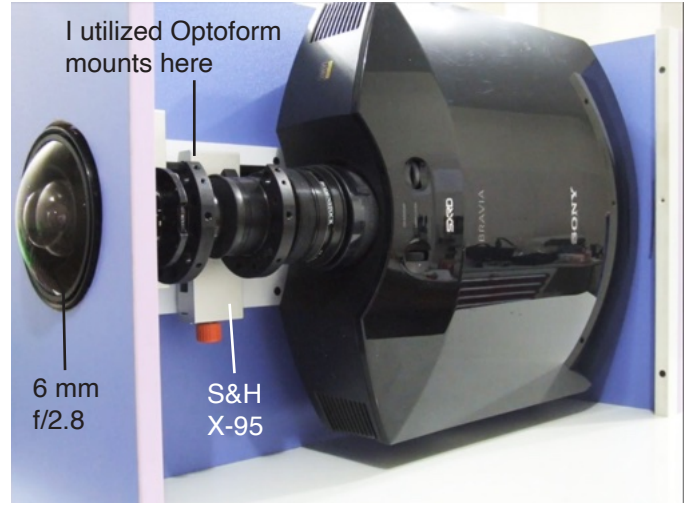
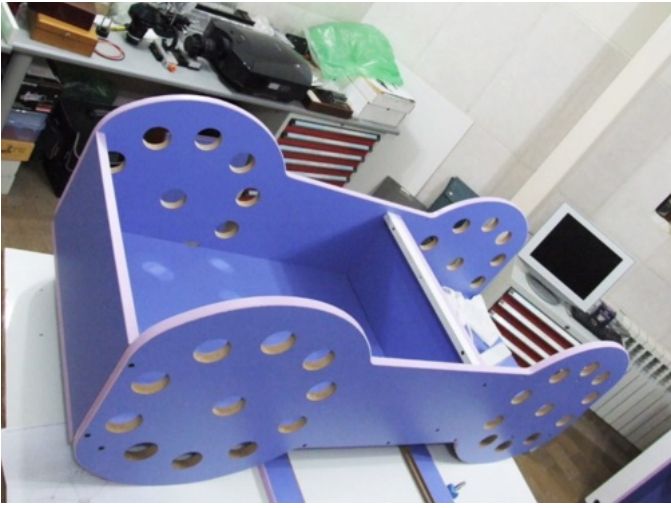

The projector consisted of a Nikon 8 mm f/2.8 fisheye lens, plus a 75 mm f/2.8 Rosenstock relay lens, and a full HD Sony projector. I used X-95 rails to install each lens installed on a flat panel in the middle of the housing.

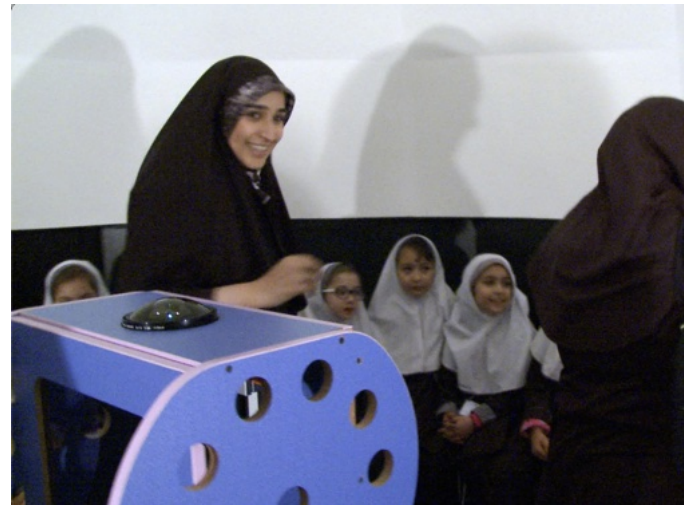

When ready, OMiD museum displays surrounded the Planetarium. Children are amazing audience for a planetarium because of their genuine curiosity, and vivid imagination. Over 120 children visited daily, divided in 18 groups at a time.



I just came to realize 165 of these same looking children were bombed recently at a girl's school in the village of Minab in Iran, and they all perished along with their teachers. How tragic war is, and for what reason?

The Art of Spindler & Hoyer

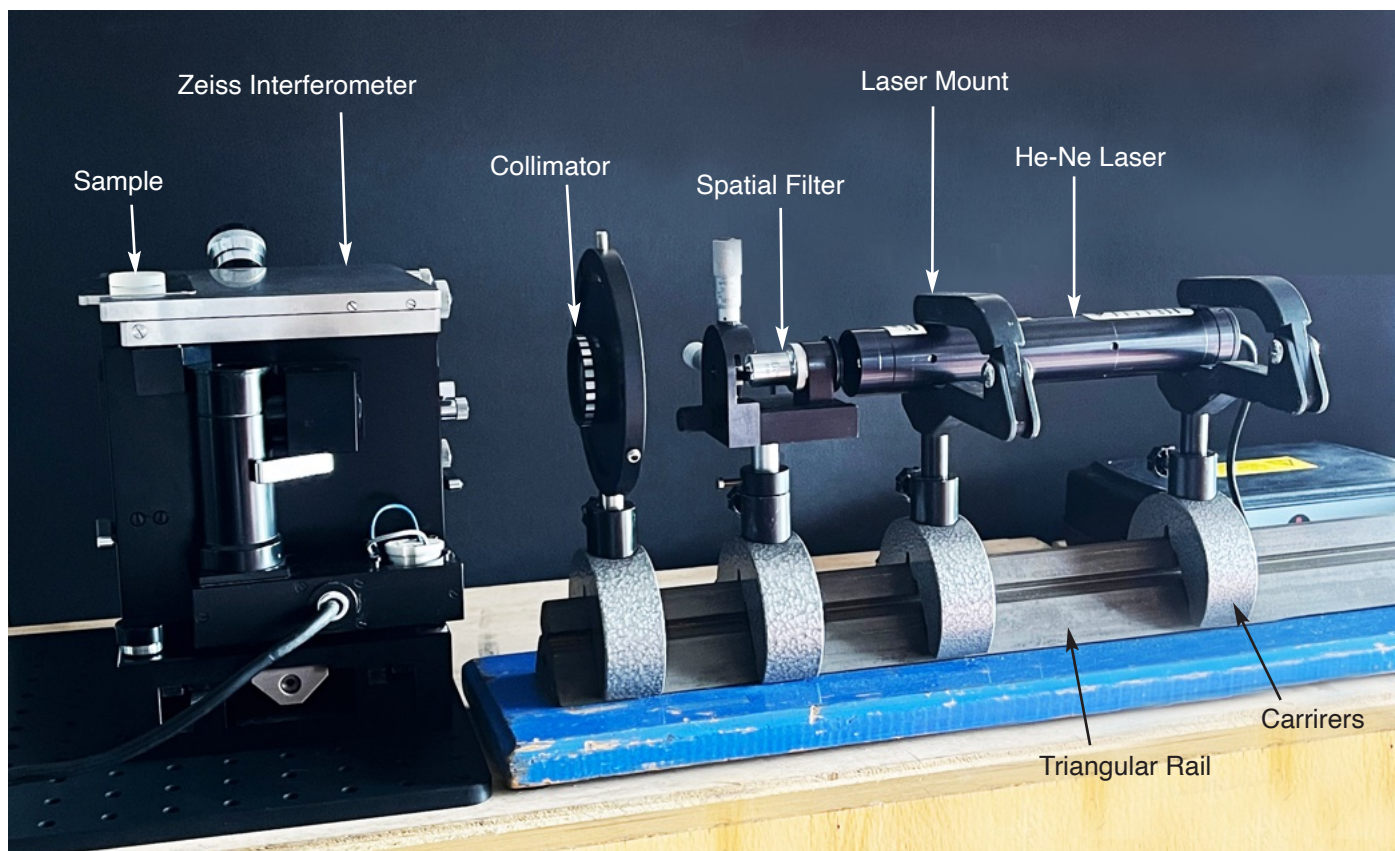

The Zeiss interferometer is using a He-Ne laser light source to show the profile of a flat mirror surface placed on its top.

Just when you thought you know something, re-examine it. I have always suggested to my readers that if you really want to understand something, hand draw it. In my age, I have come to understand things by looking at them. That's how the eyes get trained through years of drawing everything I saw. In any case, what I'd like to discuss with you is the design, and contributions of Spindler & Hoyer's in Opto-mechanics. They are simply the best out of Europe, along with their precision stages made by Micro-Control of France. These two factories joined together in Spindler & Hoyer's catalog to offer a product range that I still consider the best in the world. In motorized stages, I thought Micos, and PI lead the way with their obsession with Mac-like design (less is more lead by Dieter Rams). They would make most American made products like Newport, and Thorlabs look like a toy. Melles Griott paid some attention to details but they are no longer around. I guess that would leave Opto-Sigma but it's Japanese.

The Triangular Profile Rail System



Triangular rails, with scale

Length (mm)	Cat. No.	Length (mm)	Cat. No.
250	02 2028	1500	02 2153
500	02 2053	2000	02 2203
1000	02 2103		

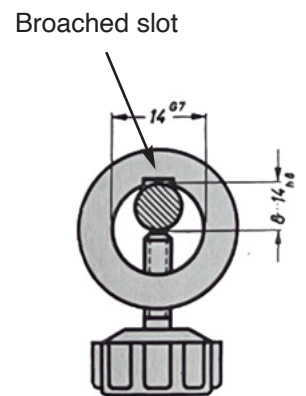
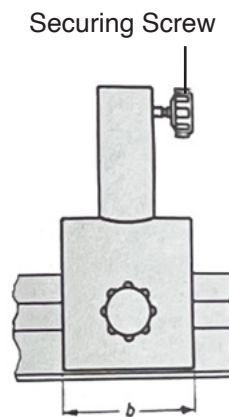
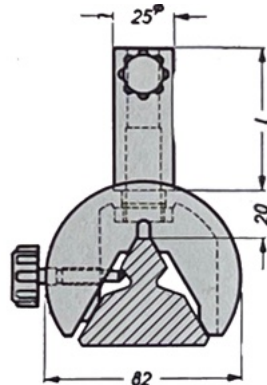
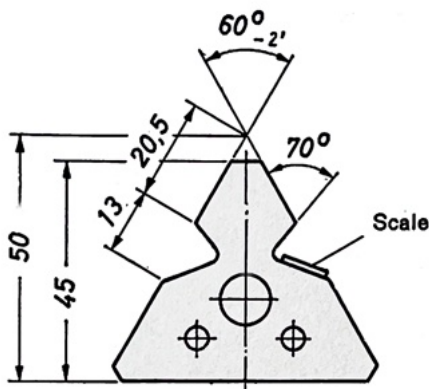
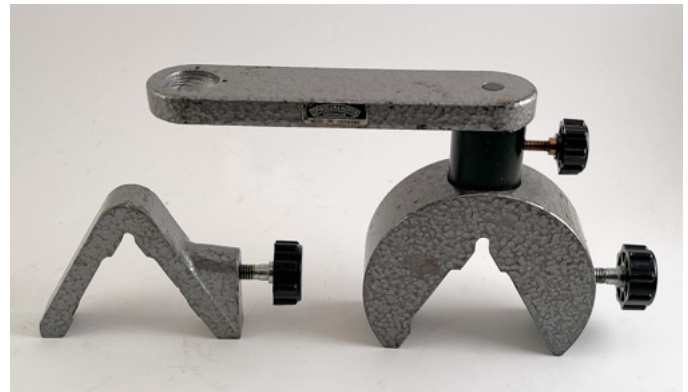
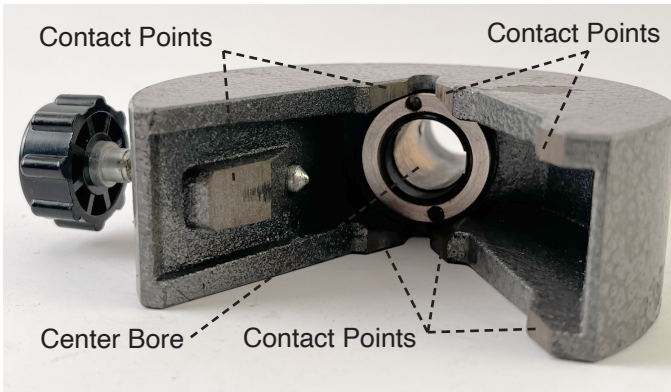

One feature of these post mounts is the center bore (above, left) is a through hole, so the post can be lowered until it touches against the rail. Above-right, the broached slot allows various size rods to be secured, with of course, proper orientation of the securing screw as shown in the drawings.

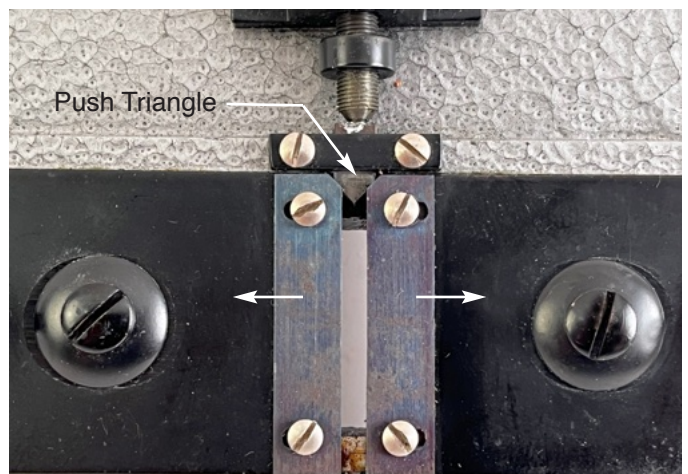
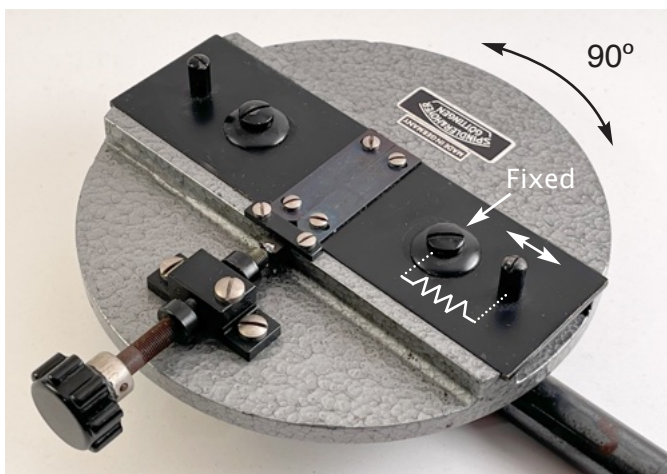

One fascination Spindler and Hoyer had was to make precision adjustable width slits. There is also a low-cost version shown on next page. This 4" diameter variable slit rides on a rotary mount with adjustable stops on both ends of its 90-degree range to allow vertical, and horizontal orientation. If you think about it, it really takes an adequate micro mechanism to build adjustable-width slits.

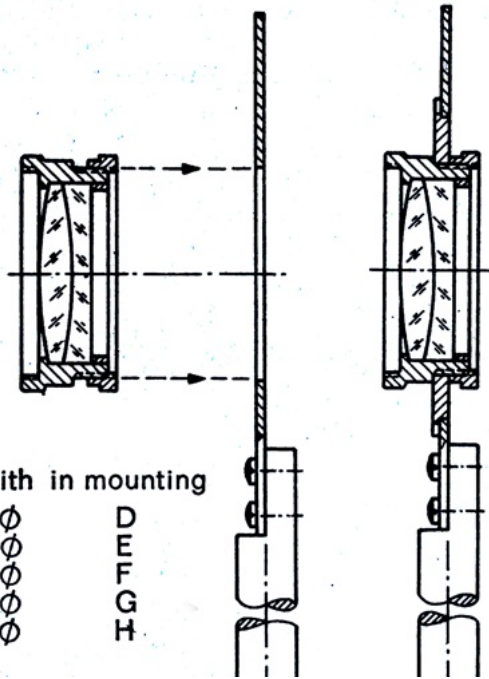

4" square lens boards with various center bores will carry lens mounts ranging from 31.5 to 80 mm in diameter (above). Right, a unique method of holding lenses.

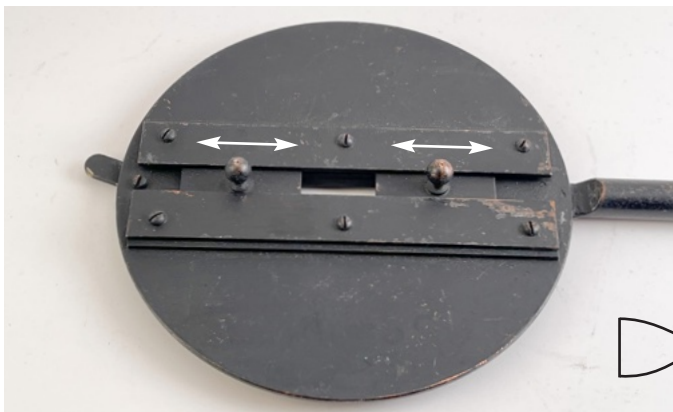

Adjusting Slit Height

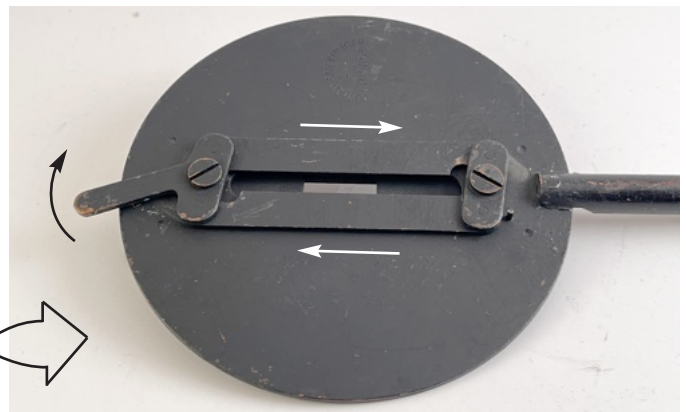

Adjusting Slit Width

Simple but old-fashioned way to create a slit. In real use, this isn't suitable for diffraction experiments, but good for masking

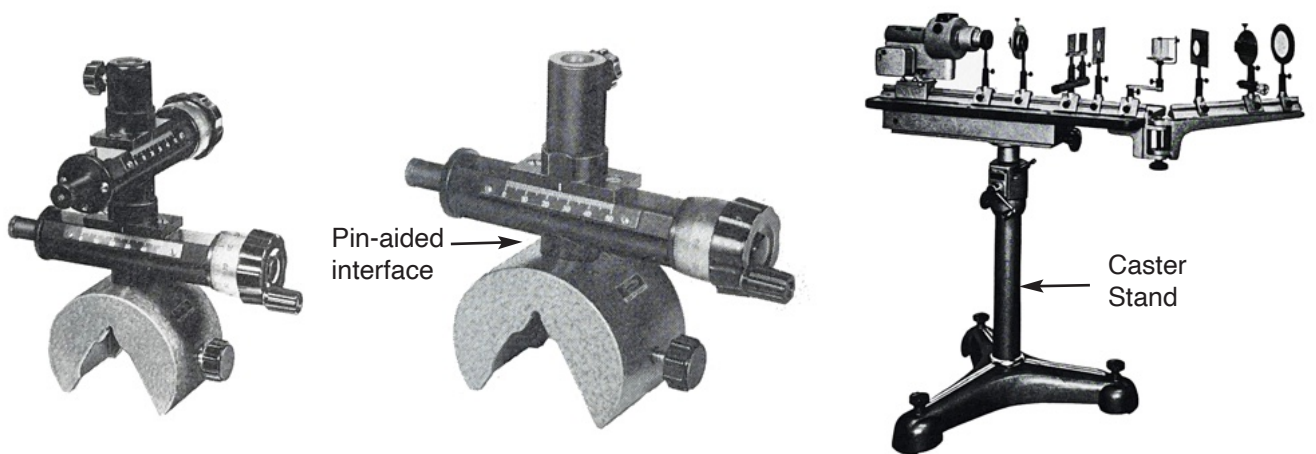

These configurations are unheard of in modern optical lab accessories, although the stand on the right can be constructed utilizing X-95 rails. The linear translators (left, middle) utilize a series of micro dovetail grooves as linear translation guide. The non-rotating interface between the rails, and post mounts is so essential. This pin aided interface is stackable.

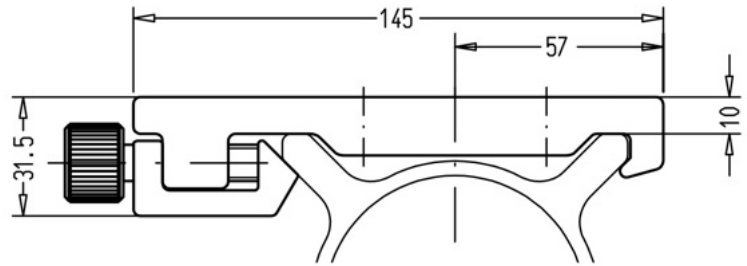
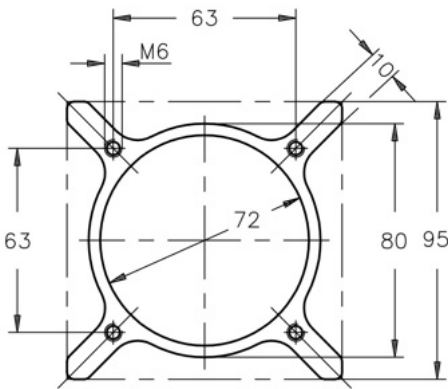
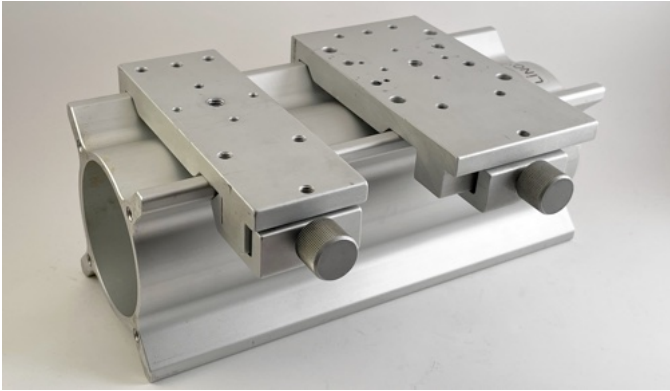
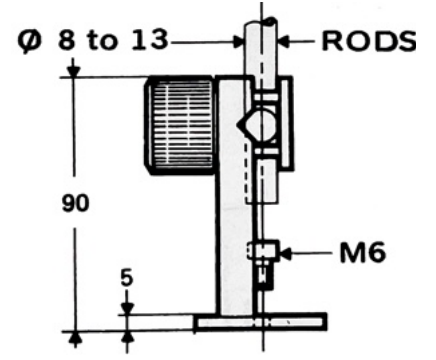
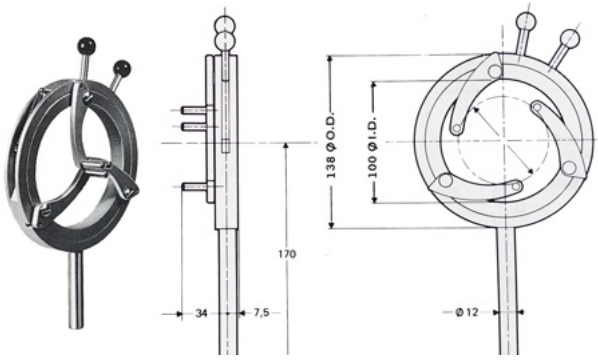

The X-95 System

X-95 design is such a modern looking / timeless design that I don't think it ever gets old. It is such an elegant and well thought of system that it by far overcomes any other system ever offered for laboratory setups.

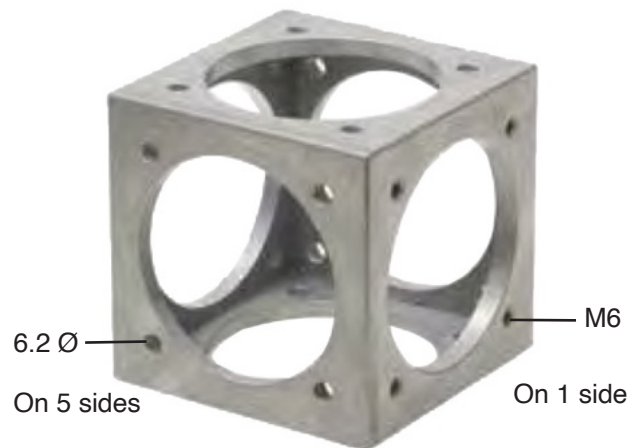

The basic application of the X profile depends on its orientation: In the horizontal mode, its bottom is perfect for securing standing legs so one could fit table-top power supplies, etc. beneath it. In the vertical mode, it is suitable for building down looking instrumentation such as inspection systems, or collimators, etc.



Microbench

Microbench was the most innovative system Spindler & Hoyer ever introduced. It is said this was originally a Zeiss design but it was the most radical optical prototyping system of its time, and it still is. Most people think it came from Thorlabs, but they copied the design after its patent was expired. It is the tinker toy of tinker toys, and the erector set of optical erector sets. I discussed this system, and its history in July-Sep 2023 issue of Optomechanix. There are many remarkable contributions that most people take for granted. The engraved lens cells were not common in optical labs. It protects lenses from being scratched, and shows both its focal length, and its direction of curvature. Its possibility for 3-D assembly, and self-holding nature enables the user to design both form, and function.



Left, no system has yet reached the versatility of Microbench. I was inspired by Microbench to create the Optoform line, which was a circular version of it. While creating the new Optoform II, I went back to the square form, and it's the same size.

God's hope in Movies

By Ali Afshari

Human beings need a savior — and this has been the central theme of this series of articles titled “God’s Hope.” God is like an ocean: when you approach it, you cannot contain it, but it contains you. If your body is stained, you cannot stain the ocean — it cleanses you. And deep beneath its surface, it hides its pearls.

Regarding human nature, Freud divides the inner self into three elements: The id (instinctual drives), ego, and superego. But I prefer how Erich Fromm names them: The child, the adult, and the parent. The child follows instinctive drives, the parent instills moral conscience, and the adult must decide — through rational and logical thinking — whom to follow. In his seminars, Tony Robbins offers a great framework for change: The king, the warrior, and the magician, oriented toward breaking the destructive habits we develop as we grow up.

The king decides whom to follow. The warrior struggles for liberation, and the magician helps by reframing the problem — making it appear far more solvable than the warrior imagines. The magician is the inspired self, the positive thinker. I would like to discuss some films, because great cinema can sometimes show the path to our liberation. Satan leads us astray by glorifying our desires and making them feel irresistible. One might assume Las Vegas is the world’s sin city — yet while the Western world proclaims itself the standard-bearer of freedom and democracy, it stands silent before the tragedy unfolding in Gaza. Who, then, is truly more sinful?

Les Misérables illustrates how compassion can transform a person from darkness into goodness. In this powerful scene, the priest says to Jean Valjean: “My brother, you no longer belong to evil. With this silver, I bought your soul — I ransomed you from fear and hatred. Now I give you back to God.” This is a transformative moment, yet Valjean struggles to fulfill that promise. Consider: how does one commit to being good, and why should one bother? Desires are so pleasurable to indulge. What is the real benefit of choosing goodness?

This struggle is metaphorically illustrated in the horror film **1408**. A reporter insists on staying in a hotel room notorious for supernatural terror. Despite the manager’s urgent warnings, he remains — and endures a true nightmare. No matter what he does, he cannot escape. The film suggests that this room is a mirror of the self: what we do is who we become. In one striking scene, he attempts to flee through the window to an adjacent room, only to find every window bricked shut. He is forced to return to room 1408, haunted once again.

La Ciudad portrays the collective solidarity of people bound together by hardship — one for all, and all for one. The promise of “\$50 a day” turns out to mean ten cents per brick: pulled from rubble, cleaned, and restacked. These workers are trapped — they arrived on the back of a truck and cannot simply walk away to find other work. The film captures the anguish of undocumented immigrants in America, who have no legal protection, even when injured on the job.

State of Siege exposes the reach of CIA operations in Central America and the resistance movements that rise to oppose them. **JFK** probes the shadowy circumstances surrounding



Don't you ever forget, you promised to be new man in Les Misérables. I ransomed you from fear and hatred. Now I give you to God.



1408 is not about a hotel room, but a man's struggle with his inner self.



Take the trash out from here says Socrates in “Peaceful Warrior”.



the assassination of President Kennedy. **Peaceful Warrior** traces the journey of a seeker and his life teacher, exploring how one learns to silence the mind and master it. **Bowling for Columbine** draws a haunting connection between America's wars abroad and the violence that festers at home.

Braveheart illustrates how truly great leaders do not seek power — they are chosen by the people and called to rise. In many ways, the film mirrors Imam Hussein's historical struggle in Karbala for justice and self-determination, and his martyrdom at the hands of a vastly superior force. **Apocalypto** shows how the powerful fatally underestimate the will of the weak to survive. A band of warriors raids a village, seizing its men for use as human sacrifices in a brutal Mayan ceremony. One man escapes and fights his way back to reunite with his wife and child — and to ensure the survival of his people.

Z illustrates how the vision of Greek politician Grigoris Lambrakis can outlast his own life. The film documents the assassination of a beloved public leader at the hands of a political mob. A determined reporter uncovers the truth, and an uncompromising judge brings the conspirators to justice. This stands in sharp contrast to JFK, where the truth was buried: Jack Ruby was made to appear as the lone gunman, only to be silenced himself — and the case was closed. Today's Iran war, and Gaza's genocide needs the same uncompromised judge to bring its conspirators to justice. Wars need to stop, and tyrants must be made accountable. The injustice must stop.

Those who claim they could bring heaven on earth; they are either naive or it's deception. Because of the war, I've been watching so much Instagram because you can't hear real news through our filtered media establishment. So many events in history are created to justify wars, but later they are found to be based on a conspiracy. There has been so much evil in the world, who has learned the benefits of having an Epstein Island, and using honeypots for blackmail. According to Scott Ritter, Jeffery Sacks, John Mearsheimer, and Tucker Carlson APAC has been taking over this country, and that's why we have been dragged into this war with Iran.

Heaven, and hell can only be found inside us. Living a life with high moral values is what saves us from being trapped in room 1408. Social thinkers and teachers like Wayne Dyer, Tony Robbins, Alan Watts, Eckhart Tolle, and Rumi, and psychologists like Carl Jung, Erich Fromm, and others offer pathways out of our worst impulses and toward genuine greatness. And women, through the profound role of motherhood, hold the very cradle of our humanity.

Listen, we have the potential of God shining through each of us. Imagine the parent, the adult, and the child within us forging a relationship strong enough to raise a decent human being. When we become an adult, the choice is ours. We could learn our shortcomings, work to undo them, and strive to become the person we always wish to be. We can first pick a moral role model to follow, and the rest is the most meaningful route to finding our true heaven on earth. If you can't find the ideal role model, be one yourself. The first step is to stop preaching what we are not. Those who have found heaven, don't look for a window to escape from it. Those who committed those heinous acts on innocent children, room 1408 will be waiting for them.



His last word, William Wallace yells: "Freedom" in Braveheart



Apocalypto is about survival of an unarmed man against a brutal army, at last gaining his right to be a survivor of his people.

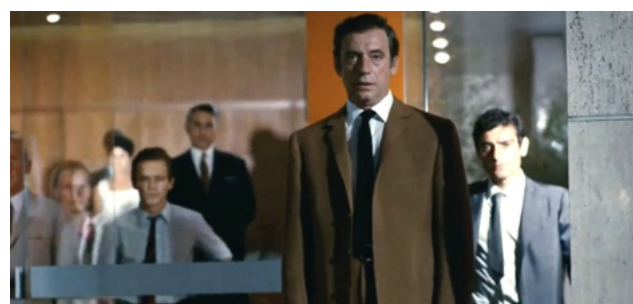

Z is about the assassination of a popular figure in Greece, and an uncompromising judge to bring the accomplices to justice.



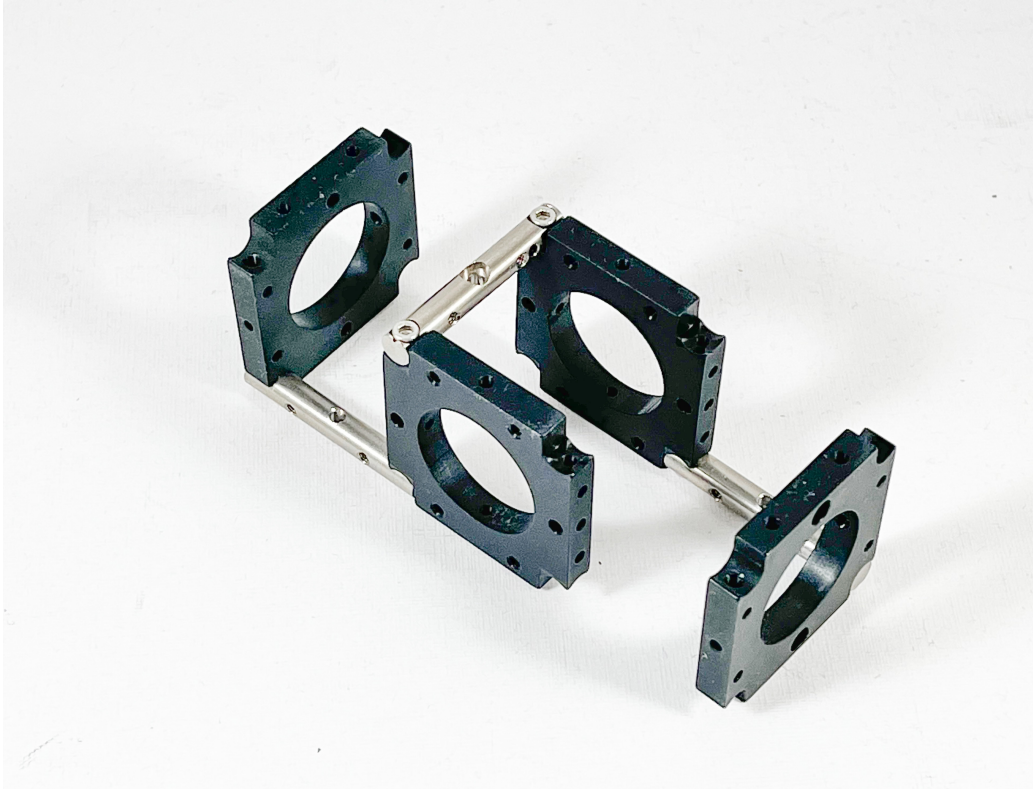

Our Instruction Manuals

Optoform's user's manuals have been compiled to follow the tradition of optical erector sets. Every page is lavishly illustrated to show how each instrument is designed, and assembled together. As your knowledge of Optoform increases, so does the level of sophistication in your assemblies. Download from:

www.optoform.com

info@optoform.com